

## DESIGN YOUR OWN RESISTOR NETWORK

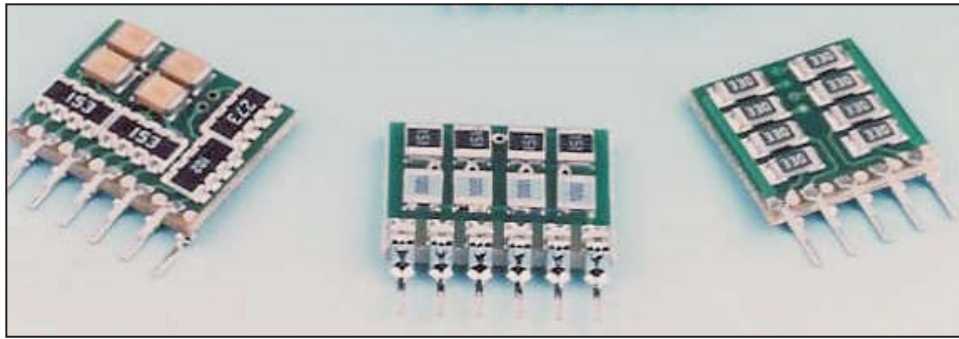

**YOU TELL US WHAT VALUE, TOLERANCE,  
AND WATTAGE YOU WANT, AND IN A FEW  
DAYS, YOU WILL RECEIVE THE  
NETWORK YOU REQUIRE**

### DESCRIPTION

The Accutek family of resistor networks is designed to create any value or combination of values of resistors into a single compact pluggable module.

Using our standard product boards, you specify what value, tolerance, and wattage is necessary and we assemble a resistor network utilizing surface mounted chip resistors into the circuit you require.

Custom designed resistor networks can also be supplied with your unique pin assignments and circuitry. Also, capacitors can be added to any module to provide filtering or termination.

### FEATURES

- Resistors of any value or tolerance
- SIP, ZIP, or DIP packaging
- Mix and match resistors and capacitors
- Standard product for quick turn
- Custom configurations for special applications

### AK06G-R5T

6 Pin SIP 5 Resistor Terminator (Bussed) Network

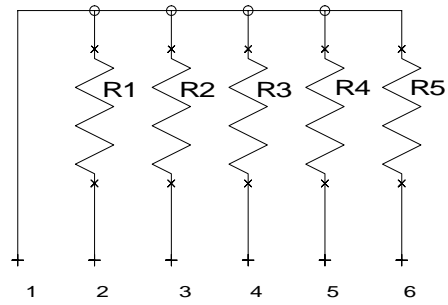
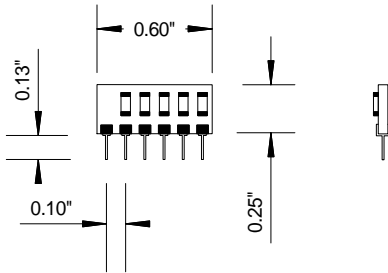

### AK07G-R6T

7 Pin SIP 6 Resistor Terminator (Bussed) Network

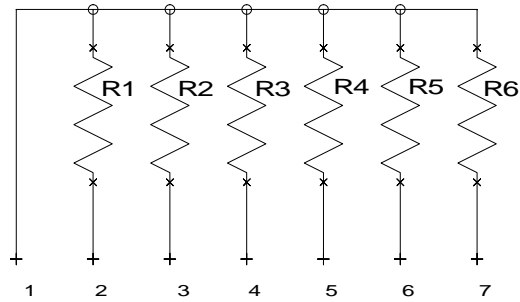
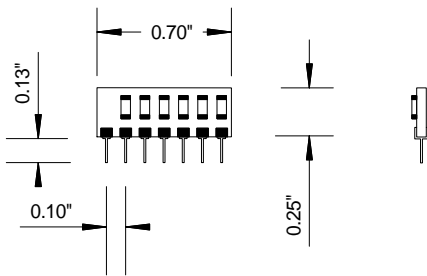

### AK08G-R7T

8 Pin SIP 7 Resistor Terminator (Bussed) Network

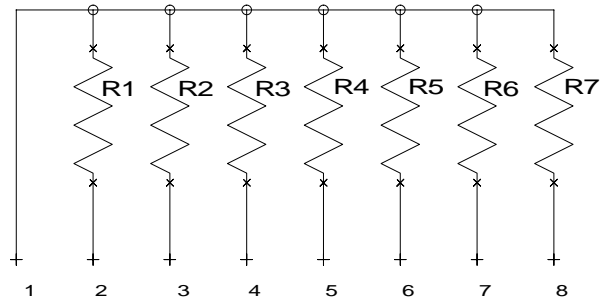
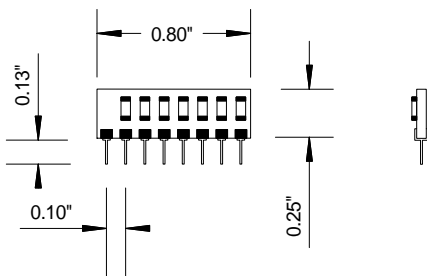

### AK09G-R8T

9 Pin SIP 8 Resistor Terminator (Bussed) Network

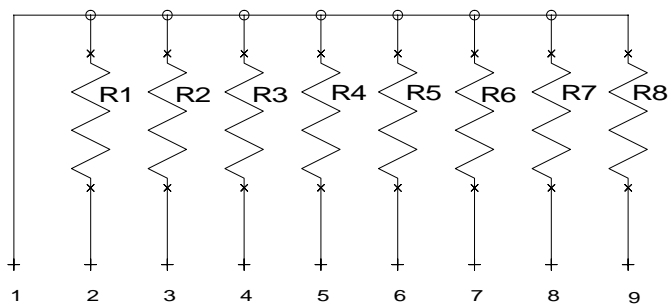
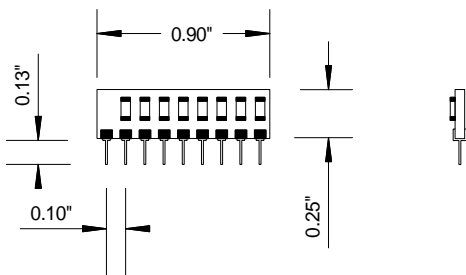

### AK10G-R9T

10 Pin SIP 9 Resistor Terminator (Bussed) Network

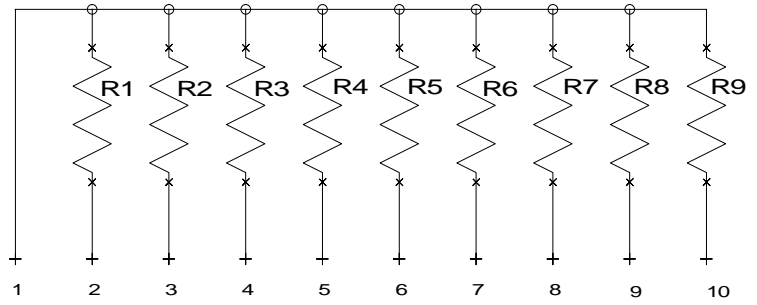
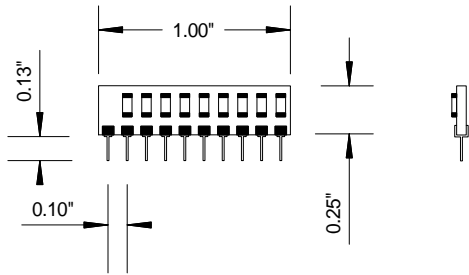

### AK11G-R10T

11 Pin SIP 10 Resistor Terminator (Bussed) Network

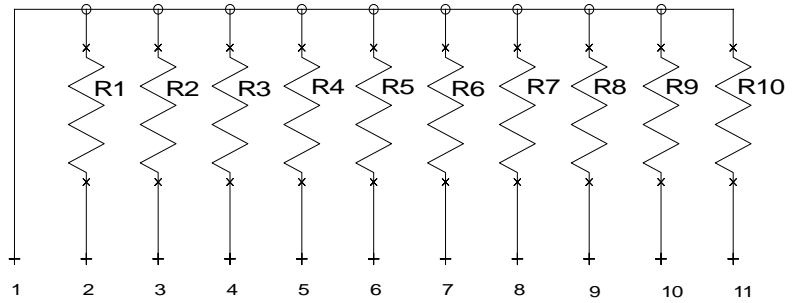
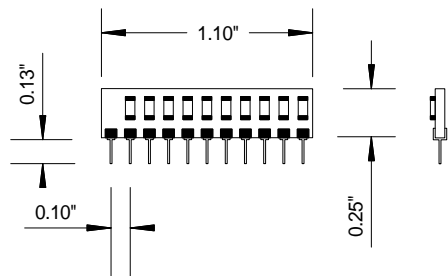

### AK12G-R11T

12 Pin SIP 11 Resistor Terminator (Bussed) Network

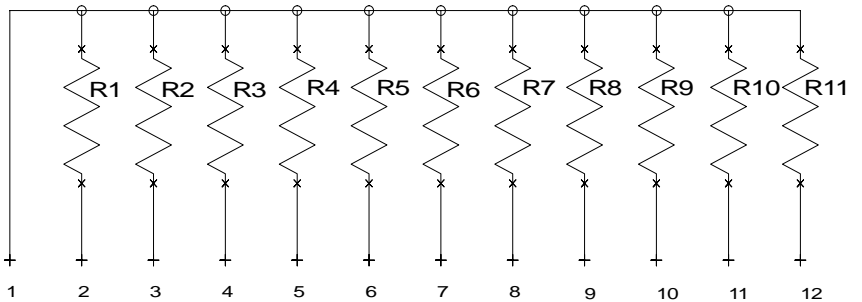
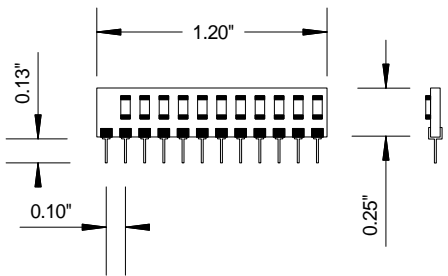

## STANDARD RESISTANCE VALUES

Standard resistance values are obtained from the decade table lby multiplying by powrs of 10.  
As an example, 1.3 can represent ohms, 1.33K, 13.3K, 133K, 1.33 megohms

<b>.1%, .25%</b>		<b>.1%, .25%</b>		<b>.1%, .25%</b>		<b>.1%, .25%</b>		<b>.1%, .25%</b>	
<b>0.5%</b>	<b>1%</b>	<b>0.5%</b>	<b>1%</b>	<b>0.5%</b>	<b>1%</b>	<b>0.5%</b>	<b>1%</b>	<b>0.5%</b>	<b>1%</b>
10.0	10.0	16.9	16.9	28.7	28.7	48.7	48.7	82.5	82.5
10.1		17.2		29.1		49.3		83.5	
10.2	10.2	17.4	17.4	29.4	29.4	49.9	49.9	84.5	84.5
10.4		17.6		29.8		50.5		85.6	
10.5	10.5	17.8	17.8	30.1	30.1	51.1	51.1	86.6	86.6
10.6		18.0		30.5		51.7		87.6	
10.7	10.7	18.2	18.2	30.9	30.9	52.3	52.3	88.7	88.7
10.9		18.4		31.2		53.0		89.8	
11.0	11.0	18.7	18.7	31.6	31.6	53.6	53.6	90.9	90.9
11.1		18.9		32.0		54.2		92.0	
11.3	11.3	19.1	19.1	32.4	32.4	54.9	54.9	93.1	93.1
11.4		19.3		32.8		55.6		94.2	
11.5	11.5	19.6	19.6	33.2	33.2	56.2	56.2	95.3	95.3
11.7		19.8		33.6		56.9		96.5	
11.8	11.8	20.0	20.0	34.0	34.0	57.6	57.6	97.6	97.6
12.0		20.3		34.4		58.3		98.8	
12.1	12.1	20.5	20.5	34.8	34.8	59.0	59.0		
12.3		20.8		35.2		59.7			
12.4	12.4	21.0	21.0	35.7	35.7	60.4	60.4	<b>2%, 5%</b>	<b>10%</b>
12.6		21.3		36.1		61.2			
12.7	12.7	21.5	21.5	36.5	36.5	61.9	61.9	10	10
12.9		21.8		37.0		62.6		11	
13.0	13.0	22.1	22.1	37.4	37.4	63.4	63.4	12	12
13.2		22.3		37.9		64.2		13	
13.3	13.3	22.6	22.6	38.3	38.3	64.9	64.9	15	15
13.5		22.9		38.8		65.7		16	
13.7	13.7	23.2	23.2	39.2	39.2	66.5	66.5	18	18
13.8		23.4		39.7		67.3		20	
14.0	14.0	23.7	23.7	40.2	40.2	68.1	68.1	22	22
14.2		24.0		40.7		69.0		24	
14.3	14.3	24.3	24.3	41.2	41.2	69.8	69.8	27	27
14.5		24.6		41.7		70.6		30	
14.7	14.7	24.9	24.9	42.2	42.2	71.5	71.5	33	33
14.9		25.2		42.7		72.3		36	
15.0	15.0	25.5	25.5	43.2	43.2	73.2	73.2	39	39
15.2		25.8		43.7		74.1		43	
15.4	15.4	26.1	26.1	44.2	44.2	75.0	75.0	47	47
15.6		26.4		44.8		75.9		51	
15.8	15.8	26.7	26.7	45.3	45.3	76.8	76.8	56	56
16.0		27.1		45.9		77.7		62	
16.2	16.2	27.4	27.4	46.4	46.4	78.7	78.7	68	68
16.4		27.7		47.0		79.6		75	
16.5	16.5	28.0	28.0	47.5	47.5	80.6	80.6	82	82
16.7		28.4		48.1		81.6		91	