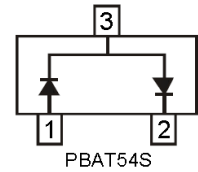
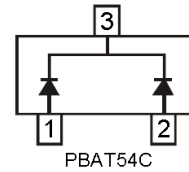
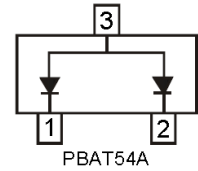
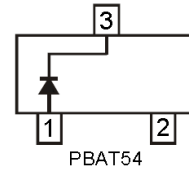

**Features**

- Low Forward Voltage
- High Current Capability
- Extremely Fast Switching Speed

**Applications**

- Ultra high-speed switching
- Voltage clamping
- Protection circuits
- Blocking diodes.

**Mechanical Characteristics**

- Lead finish:100% matte Sn(Tin)
- Mounting position: Any
- Qualified max reflow temperature:260°C
- Device meets MSL 1 requirements
- Pure tin plating: 7 ~ 17 um
- Pin flatness: ≤3mil

**Electrical characteristics per line@25°C**

Parameter	Symbol	Min.	Typ.	Max.	Unit	Conditions
Maximum forward voltage	VF1			500	mV	I <sub>F</sub> =30mA
	VF2			1000	mV	I <sub>F</sub> =100mA
Maximum reverse breakdown voltage	VR	30			V	IR=100uA
Maximum reverse current	IR			2.0	uA	VR=25V
Reverse recovery time	trr			5	nS	I <sub>F</sub> =I <sub>R</sub> =10mA I <sub>rr</sub> =0.1XIR, RL=100Ω
Junction Capacitance	C <sub>J</sub>		18	30	pF	V <sub>R</sub> =0V f = 1MHZ

Absolute maximum rating@25°C

Parameter	Symbol	limit	Unit
Maximum repetitive peak reverse voltage	$V_{RRM}$	30	V
Maximum RMS voltage	$V_{RMS}$	21	V
Maximum DC blocking voltage	$V_{DC}$	30	V
Maximum average forward rectified current	$I_{FM}$	200	mA
Peak forward surge current 8.3ms single half sine-wave	$I_{FSM}$	600	mA
Typical thermal resistance	$R_{\theta JA}$	500	°C/W
Powe Dissipation	$P_D$	200	mW
Junction Temperature	$T_J$	125	°C
Storage temperature range	$T_{STG}$	-50~+150	°C

Typical Characteristics

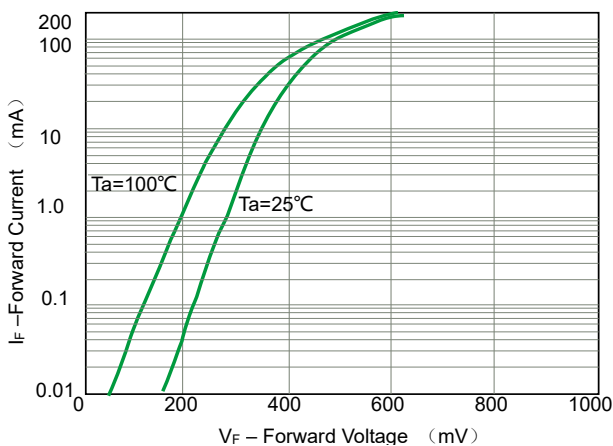

Fig 1. Forward Characteristics

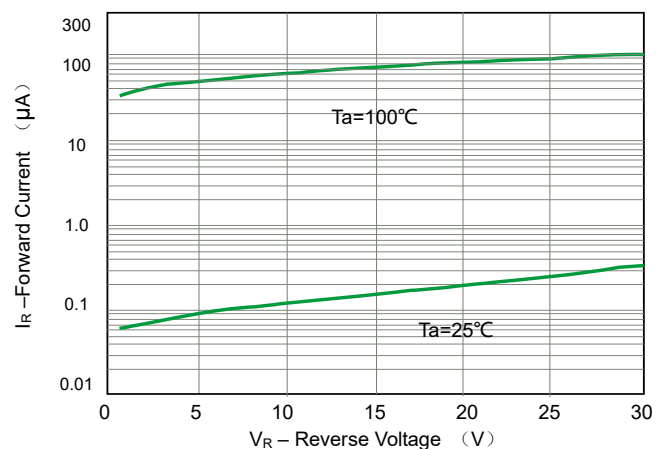

Fig 2. Reverse Characteristics

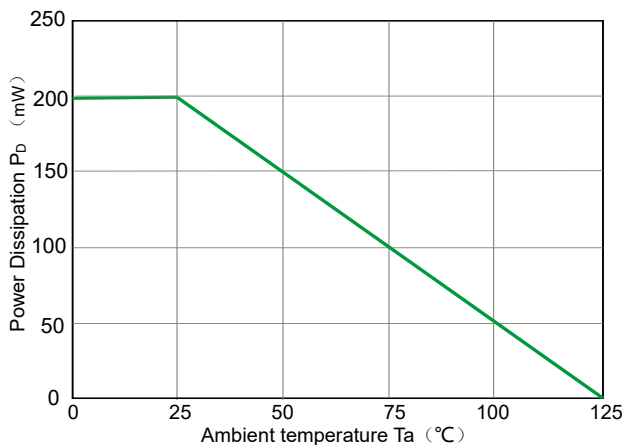

Fig 3. Power Derating Curve

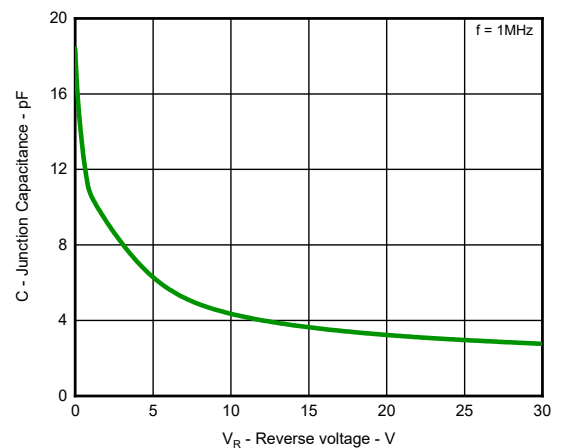
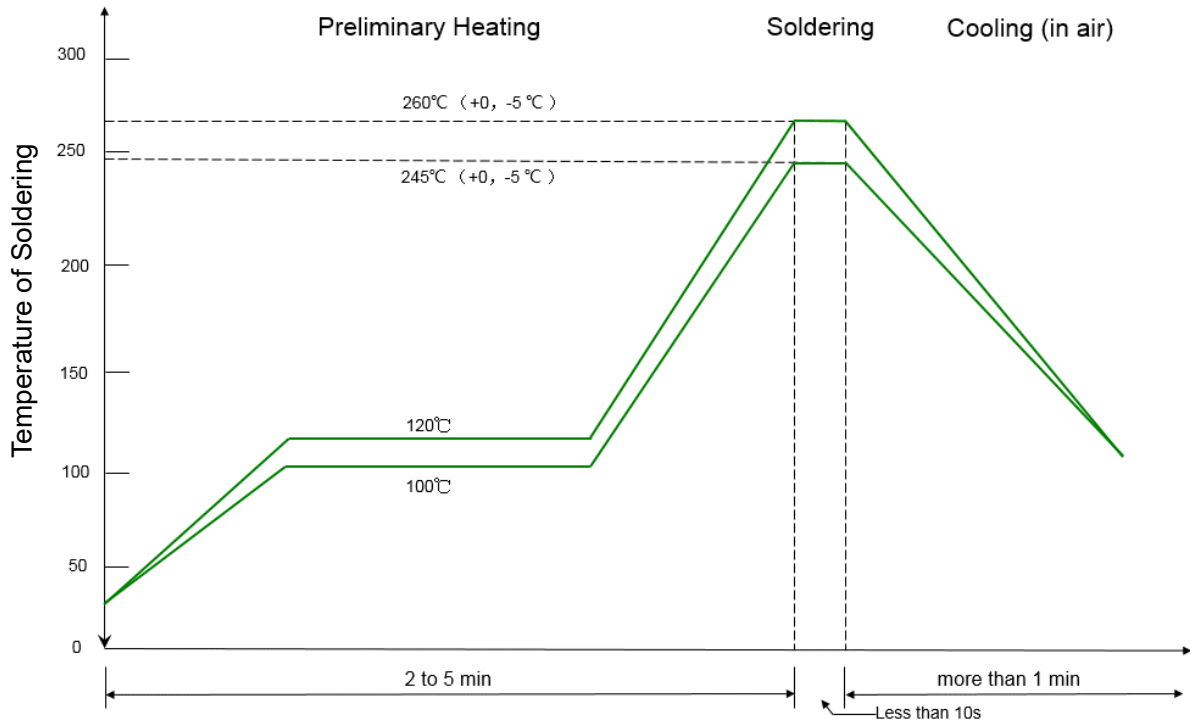

Fig 4. Capacitance vs. Reverse voltage

Solder Reflow Recommendation



Remark: Pb free for 260°C; Pb for 245°C.

Product dimension(SOT-23)

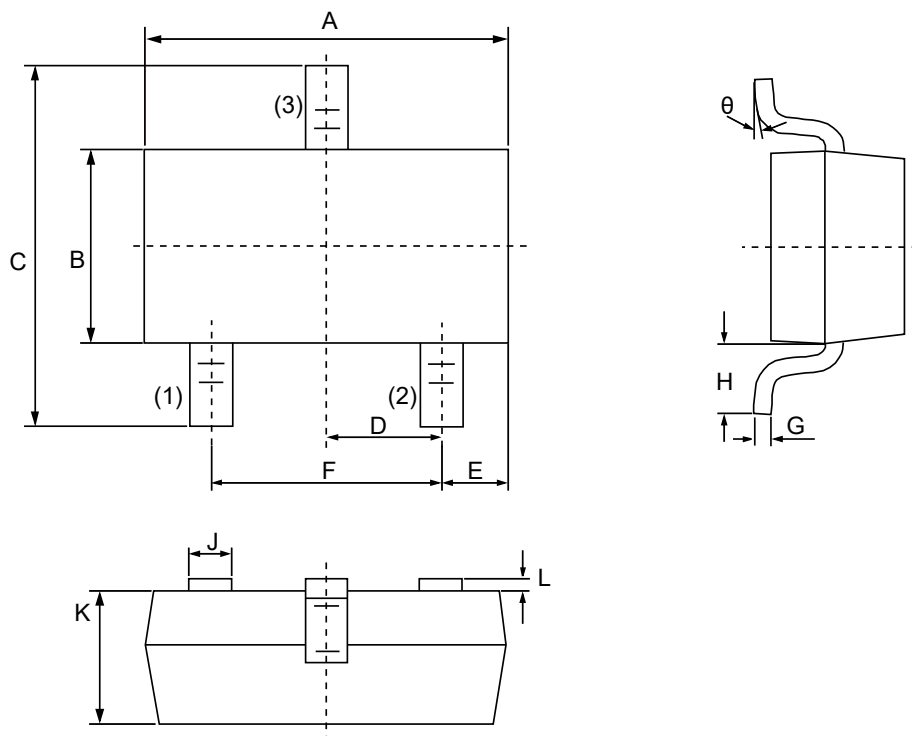

Dim	Millimeters		Inches	
	MIN	MAX	MIN	MAX
A	2.80	3.00	0.110	0.118
B	1.20	1.40	0.047	0.055
C	2.25	2.55	0.089	0.100
D	0.95 Typ.		0.037 Typ.	
E	0.40	0.60	0.016	0.024
F	1.80	2.00	0.071	0.079
G	0.08	0.15	0.003	0.006
H	0.55 Ref.		0.022 Ref.	
J	0.30	0.50	0.012	0.020
K	0.90	1.05	0.035	0.041
L	0.00	0.10	0.000	0.004
$\theta$	0°	8°	0°	8°

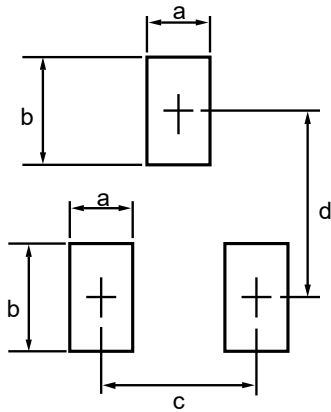

Dim	Millimeters	
	MIN	MAX
a	--	0.7
b	--	1.2
c	--	2.0
d	--	2.2

**IMPORTANT NOTICE**

 and **Prisemi**<sup>®</sup> are registered trademarks of **Prisemi Electronics Co., Ltd** (Prisemi). Prisemi reserves the right to make changes without further notice to any products herein. Prisemi makes no warranty, representation or guarantee regarding the suitability of its products for any particular purpose, nor does Prisemi assume any liability arising out of the application or use of any product or circuit, and specifically disclaims any and all liability, including without limitation special, consequential or incidental damages. “Typical” parameters which may be provided in Prisemi data sheets and/or specifications can and do vary in different applications and actual performance may vary over time. All operating parameters, including “Typicals” must be validated for each customer application by customer’s technical experts. Prisemi does not convey any license under its patent rights nor the rights of others. The products listed in this document are designed to be used with ordinary electronic equipment or devices, Should you intend to use these products with equipment or devices which require an extremely high level of reliability and the malfunction of with would directly endanger human life (such as medical instruments, aerospace machinery, nuclear-reactor controllers, fuel controllers and other safety devices), please be sure to consult with our sales representative in advance.

Website: <http://www.prisemi.com>

For additional information, please contact your local Sales Representative.

©Copyright 2009, Prisemi Electronics

 **Prisemi**<sup>®</sup> is a registered trademark of Prisemi Electronics.

All rights are reserved.