Application Note

Secondary Line Protection for T1 and E1 Line Cards

Roger Taylor

The lower cost of high speed digital T1 and E1 trunk lines has resulted in the increasing deployment of this technology in place of traditional analog lines. In the past, T1/E1 trunks were used primarily in protected telephone company central office transmission applications, but now they are used outside the central office to bring higher capacity service directly to customers. The broader application of this technology makes it important for line card designers to include secondary protection circuitry in their designs.

Line cards are exposed to a wide variety of electrical hazards through the transmission lines which connect them to the network. Even line cards installed on inside lines in a protected central office or customer premises environment are subject to line induced hazards capable of damaging line interface ICs. Line cards connected to outside lines are especially subject to the hazards of lightning surges and contact with AC power distribution facilities. The use of appropriate board-level secondary protection devices can dramatically improve the reliability and robustness of line cards in all applications.

This application note is organized into four major sections. The first is a description of the hazards line cards are exposed to through transmission lines. This section establishes the practical importance of protection circuitry. Presented next, is an overview of the major transient immunity and electrical safety standards which establish realistic immunity levels against these threats. Then, a comprehensive survey of the many transient protection devices now

available helps explain which components are best suited to T1/E1 applications. Finally, three application circuits with line protection are presented along with explanation of how each responds to various faults.

LINE CARD THREATS

There are three general types of threats to which line cards are exposed: lightning surges, AC power faults, and improper installation or maintenance practices.

Lightning Surges

T1/E1 Line cards are exposed to lightning induced damage through surges coupled either through their transmission lines or through the AC power system. Although power supplies are often designed with excellent surge immunity, many line card designs do not provide adequate board level protection to prevent damage during lightning surges through transmission line connections. The type of line protection a card requires depends upon the nature of the lines it is connected to.

For outside lines, spark gap or gas tube primary protectors are installed at the network interface. Unfortunately, these devices will not limit voltages and currents to levels safe for semiconductor ICs on line cards. Primary protectors are only designed to limit voltages and currents below levels where premises wiring might ignite. Because of the way they are connected, primary protectors often compound the

danger of surges on outside T1 lines. Typically, gas tubes or carbon block arrestors are installed on outside T1 lines between TIP to ground and RING to ground. A lightning surge will generate a longitudinal, or common-mode, transient on both TIP and RING conductors. Ideally, the longitudinal surge should not damage components on the card because the line coupling transformers will not pass a common mode signal. Unfortunately, the line coupling transformer's interwinding capacitance does couple fast transients across the transformer potentially damaging sensitive components. Also, the primary protection components will convert some of the longitudinal transient energy to a metallic transient because the two protectors on each TIP/RING pair breakdown asymmetrically. [2] When one of the primary protectors fails or limits at different potential than the other, a smaller metallic TIP to RING transient results. This smaller metallic transient will be coupled across the line transformers and may also damage sensitive components on the line card.

The primary protectors with the highest let-through energy are 3-mil carbon blocks. These devices have a maximum 3-sigma limiting voltage of 1 kV peak under transient conditions and 600 VRMS at 60 Hz. [17] In the event that one primary protector fails completely and the other does not, equipment on outside lines may be exposed to voltages within these limits and should provide adequate secondary protection to withstand them.

Intra-building T1 lines do not have primary protectors so they will not see metallic surges created by primary protector asymmetry. However, they may still be damaged by longitudinal surges coupled through the line transformer interwinding capacitance. (Note that Bellcore network equipment standards still require equipment on inside lines have immunity from low energy, metallic lightning surges so that secondary metallic protection is still necessary.)

AC Power Faults

AC power cross faults can occur because of the close proximity of telephone lines to AC power distribution lines on utility poles and in building wiring. Power cross faults result from direct contact between a T1 line and an AC power line. This type of fault can result in as much as 600 VAC across a T1 line. Unfortunately, in the past many designers of telecommunications equipment designed only for worst case power cross faults and overlooked the danger from low voltage power cross faults. Such designs typically used a large fuse (e.g., 1 Amp) in conjunction with a 200 V to 300 V voltage limiting device such as a Metal Oxide Varistor (MOV). [12] This type of interface will open the fuse providing protection for faults above the MOV breakdown voltage. However, during sustained faults below the MOV breakdown voltage, this design will allow steady state fault currents which result in component heating and a fire hazard. Adequate series current limiting protection should be provided to prevent fire and electrical safety hazards resulting from *all* power cross faults. Most electrical safety standards have been revised to include additional testing below the breakdown voltage of secondary shunt protectors.

Although AC power cross faults pose a more serious threat to telecom lines, AC power induction can impair performance also. Through electromagnetic coupling, currents in nearby AC power lines can induce long-term, common mode interference on telephone lines. [17] While digital T1 lines are less sensitive to this type of interference than analog subscriber lines, proper longitudinal balance is important in both applications. Secondary protection circuitry must be designed to maintain longitudinal balance.

Bellcore TR-EOP-000001 contains additional information and statistics on disturbances at the Network Interface (NI) due to lightning, AC power or RF transmission systems. [16]

Maintenance Related Hazards

Although line cards connected to inside lines may not be directly subjected to worst case lightning surge and power cross faults, they are susceptible to hazards associated with installation and general handling. Electrostatic discharge (ESD) can damage CMOS components on line cards, although most CMOS ICs now have internal protection which insures good ESD immunity. ESD damage can be prevented during maintenance or installation if grounded wrist straps and work surfaces are used. Also, twisted-pair cables should be discharged before they are connected to T1 equipment. Cables may become charged as they are "pulled" through building walls during installation. T1 equipment which uses a current source to provide span power can be damaged by the start-up transient which can result when a cable is connected to the port and current starts to flow.

Care should also be used to avoid the installation of a line card into the backplane of an operating system unless the card has been designed to allow this. Some line cards have an edge connector with long power and ground traces which will insure power is applied before other signals when the card is inserted into a live backplane. Cards which are not designed this way may present signals to CMOS ICs before power is established triggering SCR latchup. Crystal Semiconductor uses design and layout techniques to reduce susceptibility to SCR latchup.

T1/E1 line cards can be damaged if they are incorrectly connected to analog telephone lines which carry ringing and battery voltages. Damage may also occur if line card output ports are shorted to each other or to ground. Crystal Semiconductor's newest generation of T1/E1 line interface ICs have transmitter short-circuit current limiting to help prevent damage during output shorts.

TRANSIENT IMMUNITY AND ELECTRICAL SAFETY STANDARDS

Transient immunity and electrical safety requirements for T1 equipment are defined in standards published by the United States Federal Communications Commission (FCC), Underwriters Laboratories (UL) and Bell Communications Research (Bellcore). In addition, standards bodies such as The American National Standards Institute (ANSI) and the Telecommunications Industry Association (TIA) play an active role in shaping revisions to these standards.

International standards published by the CCITT, ETSI and IEC together with country-specific standards establish the requirements for systems which are marketed in other countries. CCITT K.20, IEC-801-5 and ETS 300-046-1 outline some of these requirements for E1 systems.

The major surge immunity and electrical safety standards which apply to T1 equipment are FCC Part 68, UL 1459 and Bellcore TR-NWT-001089. Article 800-4 of the 1993 National Electric Code requires that telecommunications equipment be listed by a Nationally Recognized Testing Laboratory. [12] UL 1459, Second Edition, establishes the mandated electrical safety requirements for telecommunications equipment. This equipment must also be FCC Part 68 registered before it may be connected to the public network. [1] Part 68 establishes requirements to insure that equipment will not harm the network. Bellcore TR-NWT-001089 presents new guidelines that Regional Bell Operating Companies (RBOCs) *may* require for equipment they purchase or allow customers to connect to their networks. The requirements in TR-NWT-001089 are similar to but not identical to those in UL 1459 and Part 68. The following sections summarize the key requirements applicable to T1 equipment in each of these standards.

Bellcore TR-NWT-001089

Bellcore Technical Reference TR-NWT-001089, entitled "Electromagnetic Compatibility and Electrical Safety Generic Criteria for Network Telecommunications Equipment", contains requirements for both inside and outside plant network equipment and customer premises equipment which will be used in a Regional Bell Operating Company (RBOC) network. This

document consolidates Electromagnetic Compatibility (EMC) and safety requirements found in TR-NWT-000063, FR-NWT-000064 and TR-TSY-000499. In all future issues of these standards, EMC and safety criteria will be replaced by references to TR-NWT-001089.

Under TR-NWT-001089 telecommunications equipment is classified into one of four type categories based upon the nature of its connection to the network and intended operating environment. Table 1 summarizes the major requirements in TR-NWT-001089 which apply to each equipment type. The following sections summarize the lightning surge, AC power fault, current limiting protector, and short-circuit tests for telecommunications ports.

Section	TR-NWT-001089 Requirement	Type:	Teleco Premises	Teleco Premises	Customer Premises	Customer Premises
			Outside Lines	Inside Lines	Outside Lines	Inside Line
			1	2	3	4
2.4	ESD Immunity		X	X	X	X
3.2	EMI		X	X	X	X
4.5.3	NRTL Listing		X	X	X	X
4.5.4	Short-Circuit Test (Telecom Ports)		X		X	
4.5.6	First-Level Lightning Surge Test (Telecom Ports)		X		X	
4.5.7	Second-Level Lightning Surge Test (Telecom Ports)		X		X	
4.5.8	Intra-Building Lightning Surge Test (Telecom Ports)		X	X	X	X
4.5.9	AC Lightning Surge Test (AC power Ports)		X	X	X	X
4.5.10	Current Limiting Protector Test (Telecom Ports)		X		X	X
4.5.11	First-Level AC Power Fault Test (Telecom Ports)		X		X	
4.5.12	Second-Level AC Power Fault Test (Telecom Ports)		X			
4.5.13	Second-Level AC Power Fault Test Series Equipment (Telecom Ports)		X			
4.5.14	Second-Level AC Power Fault Test CPE (Telecom Ports)		X		X	
4.5.15	Second-Level Intra-Building AC Power Fault Test (Telecom Ports)					X
5	Steady State Power Induction		X		X	
6	DC Potential Difference		X		X	
7	Electrical Safety		X	X	X	X
8	Corrosion		X		X	
9	Bonding and Grounding		X	X	X	X

Table 1. TR-NWT-001089 Requirements vs. Equipment Type

Lightning Immunity

TR-NWT-001089 has lightning immunity tests for equipment installed on inside lines only (type 2 or 4 systems) and tests for equipment installed on outside lines (type 1 or 3 systems). These tests use the standard double exponential surge waveform shown in Figure 1.

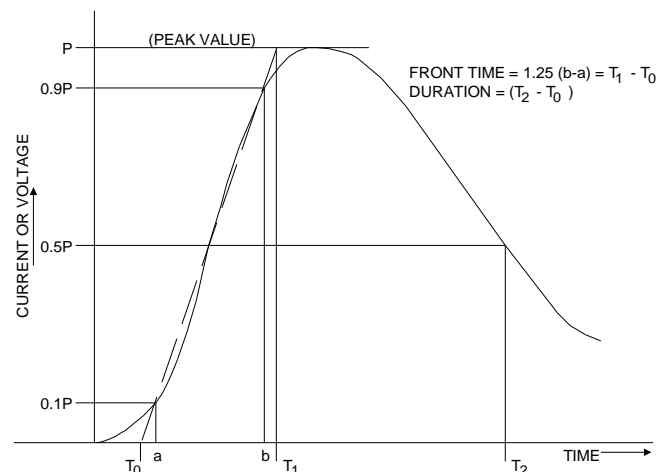

Figure 1. Double Exponential Surge Waveform

Equipment designed to connect to outside lines is subject to the first level longitudinal and metallic surge tests summarized in Table 2. After these tests the equipment must function correctly.

Surge	Min. Voltage ³ [Vpk]	Rise/Decay Time [μs]	Min. Current [A]	Repetitions Each Polarity
1. L,M	±600	10/1000	100	25
2. L,M	±1000	10/360	100	25
3. L,M	±1000	10/1000	100	25
4. L	±2500	2/10	500	10
5. L	±1000	10/360	25	5

Notes:

1. L = Longitudinal Mode, M = Metallic Mode
2. Surge 3 is optional in place of Surges 1 and 2.
3. These tests are repeated at a voltage just below the operating threshold of any secondary protectors.
4. Primary protectors removed.

Table 2. TR-NWT-001089 First Level Lightning Surges

Upon completion of the first level test, the second level longitudinal surge test in Table 3 is conducted. After this test, the equipment may be damaged but must not pose a fire, fragmentation or electrical safety hazard.

Surge	Min. Voltage ³ [Vpk]	Rise/Decay Time [μs]	Min. Current [A]	Repetitions Each Polarity
1. L	±5000	2/10	500	1

Notes:

1. L = Longitudinal Mode
2. Primary protectors removed.
3. Repeated at a voltage just below the operating threshold of any secondary voltage limiting device.

Table 3. TR-NWT-001089 Second Level Lightning Surges

Customer Premises Equipment (CPE) designed for use only on inside lines (i.e., type 4 equipment) is tested to the intra-building lightning immunity requirements in Table 4. To pass the intra-building lightning surge testing, the equipment must not be damaged. This test consists of a TIP/RING metallic surge of each polarity and a longitudinal surge of each polarity from TIP and RING to chassis ground.

Surge	Min. Voltage ³ [Vpk]	Rise/Decay Time [μs]	Min. Current [A]	Repetitions Each Polarity
1. L,M	±800	2/10	100	1
2. L	±1500	2/10	100	1

Notes:

1. L = Longitudinal Mode, M = Metallic Mode
2. Primary protectors removed.
3. Repeated at a voltage just below the operating threshold of any secondary voltage limiting device.

Table 4. TR-NWT-001089 Intra-Building Lightning Surges

Current Limiting Protector Test

The current limiting protector test applies to equipment connected to outside lines (type 1 and 3 systems), and it is designed to verify that the equipment has a time vs. current fusing characteristic which will limit fault current enough to prevent it from becoming a fire hazard or igniting the building wiring. Fuse links are provided on outside lines which might come in contact with AC power lines, but these links are only designed to meet the current handling limitation of the carbon block primary protectors and not those of downstream network equipment and wiring.

A Bussman MDQ 1.6 Ampere fuse is used in the test to simulate the fusing characteristics of premises wiring. During the test a 60 Hz, 600 VAC source is applied differentially to the telecommunication ports for 15 minutes. If the 1.6 A fuse breaks or the equipment under test becomes a fire hazard, then it must be specified for use only with external current-limiting protectors. This protection is typically provided by a 350 mA heating coil installed between the equipment and the primary voltage-limiting protector.

Short Circuit Immunity

The equipment under test must not be damaged or require any manual intervention after 30 minutes of operation with: 1) TIP shorted to RING, 2) TIP shorted to ground with RING floating, 3) RING shorted to ground with TIP floating, or 4) TIP and RING both grounded. Also, the equip-

ment under test must not become a fire or electrical safety hazard as a result of this test.

AC Power Fault Immunity

TR-NWT-001089 includes telecom port AC power fault immunity tests for type 1, 3 and 4 equipment. Equipment which will interface to an outside line (types 1 and 3) is subject to the first and second level AC power fault tests, while CPE intended for use on inside lines (type 4 equipment) is subject to the second-level intra-building AC power fault test only. These tests demonstrate the safety of the equipment under power cross and power induction fault conditions.

The first level AC power fault tests (for telecom ports) are shown in Table 5. The equipment under test should not be damaged after these tests. Note that tests 1 - 3 are performed first at the indicated voltage then repeated at a lower voltage just below the operating threshold of any secondary voltage or current limiting protectors. This additional testing insure that the equipment under test will not become a fire hazard during sustained fault current at levels below the operating threshold of secondary protectors.

Test Config. ⁴	Voltage ¹ [VRMS]	Resistance [Ω]	Primary Protectors	Duration
1. L,M	50	150	Removed	15 min.
2. L,M	100	600	Removed	15 min.
3. L,M	200 400 600	600	Removed	60 times @ 1 sec. ea. Volt.
4. L ²	1000	1000	Connected	60 times @ 1 sec.
5. L ³	600	N/A	Removed	60 times @ 5 sec.

Notes:

- All sources are 60 Hz sinusoidal. Tests 1-3 are repeated at a voltage just below the operating threshold of secondary protectors.
- This test insures compatibility with the primary protection device when it operates.
- This test simulates a high impedance induction fault.
- M = Metallic Mode, L = Longitudinal Mode

Table 5. TR-NWT-001089 First Level AC Power Fault

The second level AC power fault tests for telecom ports on type 1 equipment are shown in Table 6. The equipment under test may be damaged after these tests, but must not become a fire, fragmentation or electrical safety hazard. Cheesecloth is applied to the unit to serve as a fire hazard indicator. For series (i.e. non-terminating) type 1 equipment, these test are applied to network-side connections with customer-side connections open-circuited and then short-circuited. Successful completion of UL1459 testing can establish conformance with all requirements except test 1 which must still be performed.

Test Config. ⁸	Voltage ¹ [VRMS]	Current ⁹ [A]	Duration
1. L,M	120 277	25	15 min.
2. L,M	600	60	5 sec.
3. L,M	600	7	5 sec.
4. L,M	100-600	2.2	15 min.
5. L	600	N/A	15 min.

Notes:

- All sources are 60 Hz sinusoidal. Tests are repeated at a voltage just below the operating threshold of secondary protectors.
- This test insures compatibility with the primary protection device when it operates.
- Test 1 simulates secondary contact.
- Test 2 simulates primary contact.
- Test 3 simulates short-term fault induction.
- Test 4 simulates long-term fault induction.
- Test 5 simulates a high impedance induction fault.
- M = Metallic Mode, L = Longitudinal Mode
- Tests are repeated at a current just below the operating threshold of any current limiting protectors. Fuses are bypassed and current is set to 135% of the fuse rating.

Table 6. TR-NWT-001089 Second Level AC Power Fault Tests

The second level AC power fault tests for telecom ports on type 3 equipment are somewhat different. First a 300 VRMS, 60 Hz source is applied between all exposed conductive surfaces of the equipment and ground. To pass this part of the test current must remain below 20 A. Next, the 60 Hz sinusoidal source is applied in both longitudinal then metallic configurations to the telecom ports through a 20 Ω resistor (on each conductor) and a wiring simulator fuse (Bussman MDQ 1.6 A or equivalent). The voltage is swept slowly from 30 VRMS (or lower if necessary to

bring the current below 100 mA) to 600 VRMS. The equipment under test may not become a fire or electrical safety hazard during this test, and the wiring simulator fuse must not open (indicating ignition of premises wiring occurred). The equipment may fail open circuit. After an open circuit failure another identical unit is tested at 600 VRMS for 15 minutes and must satisfy the same set of requirements.

For series type 3 equipment, these test are applied to network-side connections with customer-side connections open-circuited and then short-circuited. The wiring simulator fuse is not used during the test with customer-side connections short-circuited.

For type 4 equipment, the second level intra-building power fault test consists of test 1, at 120 V only, in Table 6. The equipment must complete this test without become a fire or electrical safety hazard, but it may fail open-circuited.

FCC Part 68

FCC Part 68 registration is required for all customer premises telecommunications equipment which connects to the public network. The requirements in Part 68 are designed to protect the network from damage caused by poorly designed equipment. Unlike Bellcore TR-NWT-001089 and UL1459, Part 68 requirements do not focus on insuring that the equipment itself will not become a fire or electrical safety hazard. Part 68 requirements establish test guidelines on hazardous voltages and currents, signal power levels, line balance, and billing protection. [6] In addition, these requirements must be meet before and after environmental stress tests.

The tests for hazardous voltages and currents consist of a leakage test and a hazardous voltage test. The leakage test places a 60 Hz AC voltage from the TIP and RING connections of each T1 ports to exposed conductive surfaces, nonregis-

tered equipment interfaces. This voltage is increased from 0 to 1000 VRMS in 30 seconds and sustained for 1 minute. At no time during the test is the current allowed to exceed 10 mA. This test is repeated with voltage increasing from 0 to 1500 VRMS between power supply primary leads and exposed conductive surfaces, power supply secondary leads, and nonregistered equipment interface ports. Leakage must again remain below 10 mA. Since these tests are intended to verify the dielectric strength of the T1 line and power supply isolation transformers, any secondary protectors which would operate during the tests should be removed.

The tests for hazardous voltages is designed to insure that the equipment will not expose the network to dangerous voltages. During this test, a 60 Hz, 120 VAC signal is applied to exposed conductive surfaces and nonregistered interface ground connections, and the voltage on TIP or RING must is not allowed to exceed 70 V for more than 1 second.

Table 7 summarizes the Part 68.302 lightning surge immunity requirements applicable to T1 equipment designed to interface to outside lines. The first surge is an 800 V 10/560 μ s pulse applied between TIP and RING (i.e., in the metallic configuration). The second surge is a 1500 V 10/160 μ s pulse applied from TIP and RING together then individually to ground (i.e., in the longitudinal configuration). For AC powered equipment, additional surges are specified between line and neutral connections of the AC line. Although Part 68 allows open-circuit failures (such as broken line fuses), the equipment

Surge	Min. Voltage ³ [Vpk]	Rise/Decay Time [μ s]	Min. Current [A]	Repetitions Each Polarity
1., M	\pm 800	10/560	100	2
2., L	\pm 1500	10/160	200	2

Notes:

1. L = Longitudinal Mode, M = Metallic Mode
2. Primary protectors removed.

Table 7. FCC Part 68 Lightning Surges

should be designed to withstand these surges to insure reliable operation in all environments.

UL1459

UL 1459, Second Edition, establishes the safety requirements for telecommunications equipment mandated by the National Electrical Code. This standard is focused primarily upon fire and electrical shock hazards and includes guidelines on equipment enclosures, printed circuit board flammability, and user accessible voltages and currents. (Refer to [12] for an in depth overview of the requirements in UL 1459 - Second Edition.)

The overvoltage tests for telecommunication ports on outside lines are summarized in Table 8. These tests are applied in longitudinal and metallic configurations through a resistor and a fuse used to simulate premises wiring. As in the TR-NWT-001089 AC power fault tests, the equipment is allowed to fail open circuit as long as it does not become a fire or safety hazard.

For series type equipment (such as a CSU/DSU), longitudinal testing is conducted on the network port with the terminal equipment port open. Metallic testing is conducted on the network port with the terminal equipment port short circuited.

Test	Min. Voltage [VRMS]	Min. Current [A]	Duration
M-1, L-1	600	40	1.5 sec.
M-2, L-2	600	7	5 sec.
M-3, L-3	600 ³	2.2	30 min.
M-4, L-4	200 ⁴	2.2	30 min.
L-5	120	25	30 min.

Notes:

1. L = Longitudinal Mode, M = Metallic Mode
2. Primary protectors removed.
3. Test repeated with current set just below the interrupting current of any secondary current limiting devices.
4. Applicable to equipment with Voltage limiting devices operating between 200 - 600 V. Voltage adjusted below the operating threshold of the secondary Voltage limiting devices.

Table 8. UL1459 Overvoltage Tests

PROTECTION COMPONENTS

This section provides an overview of the wide variety of components typically used to provide line protection for communications equipment. A brief explanation of the operating principles, advantages and disadvantages of each component is provided in order to point out the devices best suited for T1/E1 line protection applications.

Metal Oxide Varistors

Metal oxide varistors, or MOVs, are devices made from a zinc oxide material whose resistance varies with terminal voltage. MOVs provide bipolar over-voltage clamping protection and are placed in parallel with the circuitry they are protecting. An MOV is selected by specifying its maximum operating voltage and breakdown voltage. [13] At and below the operating voltage, the MOV presents a very high impedance. However, when its terminal voltage reaches the positive (or negative) breakdown voltage, the MOV's impedance decreases dramatically limiting the voltage near the breakdown voltage.

MOVs are designed to handle large surge currents, and are commonly manufactured in a disk form factor with large cross-sectional area to reduce point current density. Its large cross-sectional area unfortunately gives the MOV a large parasitic capacitance of as much as 10 nF in some models. [11] The parasitic capacitance of an MOV is inversely proportional to clamping voltage. [11] These devices are fast acting (with response times of a few nanoseconds), but they have a finite lifetime and will gradually degrade (with a reduction in clamping voltage and increased leakage) when subjected to a number of transients. [11] MOVs must be derated when specified for operation with repetitive transients. [13]

MOVs are not designed for continuous currents because they exhibit a negative temperature co-

efficient. The negative temperature coefficient can cause thermal runaway because as current flow heats the device its resistance decreases thereby increasing the current and further heating the device. Thermal runaway ultimately results in a short circuit failure of the device. For this reason, MOVs used to provide the low clamping voltages for board level secondary protection must be protected from the continuous current possible during an AC power cross fault. A fuse or PTC resistor can provide this overcurrent protection.

Although MOVs are commonly used in analog subscriber line applications because of their low cost and high surge handling capability, they are not suitable for use on digital T1 line cards because of their high parasitic capacitance.

Spark Gaps

The spark gap is another shunt (or parallel) protector which provides over-voltage limiting.

The spark gap consists of two movable electrodes separated by an air gap. A spark gap is specified by its breakdown voltage which is the potential difference between the plates just large enough to breakdown the air gap and trigger a spark across the gap. [11] The gap size is adjusted to control the breakdown voltage of the device which is typically several hundred Volts. When the voltage across the gap is below the breakdown voltage the device presents a high impedance between its terminals. Once the terminal voltage exceeds the breakdown voltage the arc which results across the terminals creates a low impedance path for current which persists until the current falls below the minimum extinguishing current level. During operation in the arc regime, the voltage across the spark gap is limited at just above the breakdown voltage.

The carbon block arrester is inexpensive and has fast response time, but also has significant disadvantages. It must be replaced after handling a

high energy transient because of electrode erosion which widens the gap and significantly increases the firing voltage leaving downstream circuitry unprotected. [11] Also, the accumulation of carbon dust between the electrodes after conduction eventually leads to erratic operation.

Because spark gaps provide clamping at high voltages and handle high currents, they are used as primary protection devices rather than board level secondary protectors.

Gas Filled Surge Arrestors

Gas filled arrestors, commonly called gas tubes, are devices which incorporate electrodes inside a sealed glass or ceramic package filled with a noble gas. Gas filled arrestors are parallel over-voltage protectors based on the same principle as the spark gap without the mechanical instability and contamination problems common in air gap devices. Since these arrestors can fail as an open circuit, some gas tube devices also include a parallel air gap for backup protection.

Gas filled protectors are specified by: DC firing voltage, surge firing voltage, arc extinguishing voltage, max. terminal voltage (during an arc), and max. surge current. [13]

The DC firing voltage is the voltage required to trigger an arc in response to a slowly increasing gap voltage (typically 75 V to 300 V specified at $dv/dt = 500$ V/s). Since the gas in the gap requires time to ionize, the breakdown voltage increases for signals with faster rise times. [13] Often, the surge firing voltage (typically specified at $dv/dt = 1000$ V/ μ S) is several times higher than the DC firing voltage. However the response time also decreases for signals with faster rise times. Both of these factors determine how much transient energy is allowed to pass through a gas tube. For signals with slow rise times the tube will conduct within microseconds after the DC firing voltage is reached. For sig-

nals with fast rise times the tube will conduct within nanoseconds after the DC firing voltage is reached, however the fast rise time can allow the signal to reach several times the DC firing voltage in a few nanoseconds. [11] To specify a gas tube that will provide effective transient protection it is necessary to know the magnitude and rise time of the transients it must suppress.

Once a gas tube begins conduction in the arc regime, the voltage drop across the device is typically between 10 V to 30 V. Conduction will continue until the voltage falls below the minimum extinguishing voltage (typically 60% to 70% of the DC firing voltage). [13] If sufficient current (as little as 10 μ A for some devices) is available the gas tube can continue to operate in the glow regime with between 50 V to 100 V across its terminals. [11] It is important that the signal fall below this voltage after a transient to extinguish this follow current. In T1/E1 applications the 3 V AMI encoded signal will not sustain follow current, although follow current is a problem in AC power line protection applications.

Gas tube arrestors have high surge current handling capability (e.g., 15 kA for an 8/20 μ S waveform), but the large current increase that occurs when the device goes from the insulating to the conducting state can produce a great deal of radiated energy potentially upsetting other system components. [11]

Gas tube arrestors have the lowest capacitance of the common shunt type protection devices which makes them ideal for use as primary protectors in T1 and higher rate digital communications applications. These devices are often used as primary protectors because of their high breakdown voltages (at least 60 to 100 V) and large surge handling capability, but some models are suitable for use as board level secondary protectors.

Like MOVs, gas tubes require current limiting protection in communications applications which are exposed to AC power cross faults. When subjected to a power cross fault, the gas arrestor can get very hot and become permanently damaged. The hot expanding gas inside can break the package seal letting the gas escape and dramatically increasing the firing voltage. In some cases, the hot gas can even shatter the case.

Fuses

Fuses have traditionally been used for inexpensive, non-resettable series overcurrent protection in telecom applications. A fuse consists of a conductive element of precise length, diameter and composition designed to melt when subjected to a specified current flow for a specified period of time. [3] For North American T1 applications, UL listed/CSA certified fuses (commonly in a 1/4" x 1/4" cylindrical glass tube package) are used. For European applications, VDE and/or SEMKO certified fuses (commonly in a 5mm x 20mm package) are required. However, both types of fuses are available in other packages. For example, the TR5 and TE5 fuses from Wickmann USA use a small, sealed plastic package making them suitable for automated wave soldering and cleaning procedures. Because the parts are pin-compatible, one PCB layout can support the UL/CSA approved TR5 and the VDE/SEMKO certified TE5.

Fuses are specified by: an operating current rating, breaking capacity rating, maximum voltage rating, and a fusing time characteristic. [3]

The operating current rating defines the maximum current at which the fuse element is stable over time. Operating current must be derated for operation at high ambient temperatures. The fuse element has a small finite resistance (less than 0.1 Ω) below its rated current and exhibits a positive temperature coefficient. A current larger than the rated current causes the element tem-

perature to increase in turn causing the resistance to increase and thereby increasing the temperature until the element melts. Once the element melts, an arc forms between the broken ends of the element dissipating power and melting back the element ends further. Ultimately the arc is extinguished when the broken ends melt apart and the voltage can no longer breakdown the air gap to sustain the arc. The breaking capacity or interrupting rating is the maximum short-circuit current which causes the fuse to break without sustaining conduction through an arc. [3] High breaking capacity fuses often use an internal arc extinguishing medium which has a higher breakdown voltage than an air gap. Low breaking capacity fuses are filled with air and rely on the air gap formed when the element melts to extinguish the arc.

The maximum voltage rating defines the maximum voltage drop across the fuse once the element is broken that will not cause an arc to form allowing a high fault current to flow. [3]

The maximum voltage and breaking current ratings define the maximum thermal energy that a fuse can safely dissipate without becoming a fire or fragmentation hazard. [3] It is important to insure that the maximum energy rating (which is the product of maximum voltage rating, maximum current and maximum time) will not be exceeded in the intended application to insure that the fuse fails safely.

The fusing characteristic defines the energy required to melt the fuse element and extinguish the resulting arc. This relationship is often presented graphically as a time vs. current characteristic curve. The fusing time is also expressed in data sheets at a multiple of the rated operating current for a specified time (e.g., 200% of the rated current for 1 second). UL 198G classifies fusing time characteristics into two categories: time delay and non time delay. Time delay, or slow-acting, fuses are designed for applications where the fuse must remain intact

during power-on inrush current surges or short duration transients.

In telecommunications applications, a fuse must be selected based upon both its ability to withstand lightning surges and its ability to open circuit quickly during an AC power cross fault before other components fail and create a fire or electrical safety hazard. Time delay fuses are often required to satisfy these two conflicting requirements. Series resistors are often used with fuses to provide additional current limiting to protect the fuse during surges.

Hybrid Resistor/Fuse Devices

The LFR-2 manufactured by IRC, Inc. is a combination series resistor and thermal fuse in one package that offers a unique solution to achieve the conflicting requirements to withstand lightning surges and still open quickly during AC power faults.

The resistor/thermal fuse is specified by: the resistance value, fusing time characteristic, and maximum surge voltage rating.

This device combines a precision resistor with a thermal fuse in an inorganic flameproof package. The internal series resistor provides surge current limiting giving the device the ability to withstand a lightning surge, and it melts quickly and safely under worst case 600 VAC power cross faults like a fuse element. The thermal fuse provides protection during sustained, low current power cross faults by opening as soon as the resistor temperature reaches 184 °C. It is this unique ability to provide protection during sustained low current faults and still tolerate lightning surges that makes the thermal fuse and resistor combination especially attractive in telecommunications applications. In order to provide this level of low voltage power cross protection using a conventional fuse, the fuse current rating would have to be so low that it couldn't withstand lightning surges. Unfortunately, the LFR-2

is non-resettable and more expensive than conventional fuses, but it provides the kind of protection which is required for telecom equipment connected to outside lines and subject to both lightning and AC power cross.

PTC Resistors

PTCs are positive temperature coefficient resistors which are also used as series current limiting protectors. In normal operation, the PTC exhibits a low resistance, but when the current dramatically increases the PTC heats up and its resistance increases sharply, limiting the fault current. When the fault is removed the device cools and resets allowing the protected circuit to operate normally. Conductive polymer PTCs which can safely handle both lightning surges and AC power cross faults are available from companies such as Raychem, but these devices will typically be stressed beyond resettable by worst case UL1459 power cross tests. [9] PTCs are well suited to use on 600 Ω lines to provide current limiting under power cross fault conditions, but their series resistance (typically 10 to 15 Ω) results in significant signal attenuation especially at high temperatures in 100 Ω T1 systems. These devices also exhibit increased resistance after they reset.

Transformers

T1/E1 systems uses transformer coupling to provide isolation on the transmission line connections. Transformers pass differential AC signals and reject common mode signals. In addition to signal coupling, transformers also provide both metallic and common mode transient protection.

The transformers commonly used in T1/E1 applications provide between 1500 V to 3000 V of primary to secondary high potential isolation. These transformers also have limited bandwidth and energy handling characteristics which pre-

vents them from coupling fast metallic transients. The transformer's bandwidth is limited by the primary & secondary coil inductances which are typically about 1 mH. Also the characteristics of the magnetic core determine how much energy the device can couple without saturating. The ET constant or Volt-microsecond rating defines the onset of core saturation. A transformer will no longer effectively couple energy at approximately 1.5 to 2 times this rating. ET constants of 15 V- μ s are typical of T1/E1 line transformers. Once saturated, the transformer presents a low differential impedance on the line. The dominant mechanism available for coupling fast transients is the winding to winding capacitance (typically 30 pF) from primary to secondary.

Schottky Diodes

Schottky diodes provide very low forward clamping voltages making them ideal for use in clamping line I/O pins on CMOS ICs. A Schottky diode is formed by creating a junction between a metal like Aluminum and an n-type semiconductor material. The resulting junction exhibits rectification like a p-n junction but with only half the voltage drop. In addition, the Schottky diode is capable of faster switching because there are no minority carriers which must recombine as in a p-n junction.

The low forward voltage and fast switching time enable external Schottky diodes to clamp IC pins before the IC's internal silicon protection diode structures turn on and sustain damage. Since Schottky diodes have low junction capacitances, they are well suited to protect T1/E1 and higher bandwidth signals. These devices have limited power handling capacity but are well suited to absorb the potentially damaging let-through energy from other secondary protectors such transformers and silicon transient suppressors.

Avalanche and Zener Diodes

Silicon diodes optimized for surge current handling rather than voltage regulation make very effective transient suppressors. These devices use avalanche and/or zener reverse breakdown mechanisms to provide parallel overvoltage limiting protection. Although both mechanisms may be used in some of the lower breakdown voltage devices, these parts are commonly called avalanche transient voltage suppressors (TVS). [11] Avalanche diodes are designed with large cross-sectional area and internal heat sinks to increase surge current handling capability. [13] Avalanche suppressors provide low clamping voltages (as low as 5 V) and have excellent reliability when operated within specifications.

Avalanche diodes are specified by: reverse breakdown voltage, reverse stand-off voltage, max. clamping voltage, reverse leakage current, shunt capacitance, peak pulse current and power, and response time. [13]

For bipolar overvoltage clamping, two of these devices may be connected anode to anode in series across the circuit they are to protect. For applications like T1/E1 line protection which are sensitive to shunt capacitance, an avalanche diode (e.g., Semtech SMBJ6.5) can be connected anode to anode in series with a low-capacitance diode (e.g., Semtech SS8198) to minimize the total capacitance. This configuration only provides unipolar clamping so another pair connected in parallel with opposite polarity across the line is required for bipolar protection. Low capacitance avalanche protectors like the Semtech LC01 and Protek Devices use this technique to achieve capacitances of 50 pF.

Low breakdown voltage avalanche suppressors with low capacitance and low leakage are commonly used as secondary board level protectors in T1/E1 line card applications.

Thyristor Crowbar Devices

The self triggered triac, or sidac, is another highly effective type of bidirectional parallel overvoltage protector. These devices are constructed with a triac whose gate is controlled by back-to-back avalanche diodes. A voltage transient is initially limited by the avalanche breakdown characteristic of the diodes until the device current becomes large enough to turn on the triac. Once the triac is turned on, it is able to sink very large transient currents while clamping the voltage across the device typically within 2 or 3 V. The triac's low clamping voltage allows it to sink large currents while minimizing power dissipation. As the transient subsides, the current decreases below the minimum holding current and the device returns to the high impedance blocking state. Unlike a gas tube protector, the breakover voltage of a sidac does not vary with the surge current magnitude and rise time (dv/dt) of the voltage transient. [4] These devices are available with breakdown voltages ranging from

30 to 600 V. The Sidactor manufactured by Teccor Electronics and the Surgector manufactured by Harris offer excellent power handling capability, fast response time and low off-state capacitance which makes them attractive for T1/E1 applications.

T1/E1 LINE PROTECTION CIRCUITS

This section illustrates how to implement transmission line protection for both inside and outside line applications with Crystal Semiconductor T1/E1 line interface ICs. These circuits are designed to limit voltages and currents on the transmission line input and output pins of the line interface IC within data sheet absolute maximum ratings.

T1, Outside Line Protection Circuit

The schematic in Figure 2 shows a T1 applications circuit for use on outside lines. This type of line protection may be used in customer premises equipment (such as a Channel Service Unit) or telephone company equipment on ports which connect directly to metallic, outside plant lines. (Note that the CS61577 requires additional receiver equalization and transmitter line build-out components not shown here for ANSI T1.403 network interface applications with carrier provided T1 lines.)

This circuit is designed to provide the lightning surge and power cross immunity required by UL 1459 - Second Edition, FCC Part 68 and Bellcore TR-NWT-001089.

During the metallic lightning surges required by Part 68 and TR-NWT-001089, this circuit provides current and voltage limiting. TVS2 and TVS3 are LC01 low capacitance, bi-directional avalanche TVS devices from Semtech. These devices were chosen because of their 1500 W (10 x 1000 μ s) peak pulse power rating and maximum clamping voltage of 16 V.

To protect the line interface IC from the energy which is coupled through the transformer, additional current or voltage limiting is provided on the line input and output pins of the IC. On the receiver RTIP and RRING pins, the 470 Ω series resistors R1 and R2 are used for surge current limiting. The use of series resistors will not reduce the receiver input signal amplitude in normal operation because the RTIP and RRING pins are high impedance inputs (> 20 k Ω). During an overvoltage on these inputs, the internal protection diodes will clamp the input a diode drop above the +5 V supply rail and the 470 Ω resistor will limit current at a safe level. R3 and R4 are 200 Ω resistors which provide the line side termination of 100 Ω .

On the transmitter output pins another approach is required since a large series resistor will attenuate the signal too much to meet the output pulse template specifications. On the TTIP and TRING output pins, Schottky diode clamps composed of D1 - D4 are used to limit these pins within approximately 300 mV of the +5 V supply and ground. Schottky diodes were chosen because their fast response time and low forward voltage will enable them to protect before the line interface ICs internal protection diodes breakdown. The 11DQ04 Schottky diodes specified will easily handle the surge currents and voltages passed through TVS2 or TVS3 and the transformers. These diodes also have low shunt capacitance which insures that they will not distort the transmitter output pulse shape.

During longitudinal (common mode) lightning surges to ground below 2500 V, this circuit takes advantage of the isolation provided by the line transformers to prevent damage without clamping. Since the line side of each transformers is floating relative to chassis ground, it is not necessary to provide common-mode clamping protection for longitudinal surges below the high potential isolation rating of the line transformers. In practice, longitudinal surges should be limited

to 1000 Vpk by the primary protectors which are installed on outside lines. However, the TR-NWT-001089 second level lightning surge tests require the system under test safely handle longitudinal surges of 5000 Vpk, although they do allow it to stop functioning. The transformers specified here are rated for high potential isolation of 3000 VRMS (at 60 Hz). The gas tubes X1 and X2 are provided to insure the transformer isolation rating is not exceeded during the 5000 Vpk second level lightning surge test in TR-NWT-001089. X1 and X2 have a surge fir-

ing voltage above 2500 V and below 3000 V so that they will not fire during the first level surge tests, but will fire during the second level test. When X1 and X2 fire, the resulting surge current will quickly open the fuse/resistors FR1 and FR2 and the circuit will fail safely.

FR1 and FR2 are 5.6 Ω LFR-2 integrated thermal fuse/resistor devices from IRC, Inc. which provide series current limiting protection during AC power cross faults. These devices are rated to handle the metallic surges in FCC Part 68 and TR-NWT-001089 without fusing. Their series resistance provides transient current limiting to protect the fuses during a lightning surge and increases the impedance TVS2 and TVS3 place across the primary protectors allowing the pri-

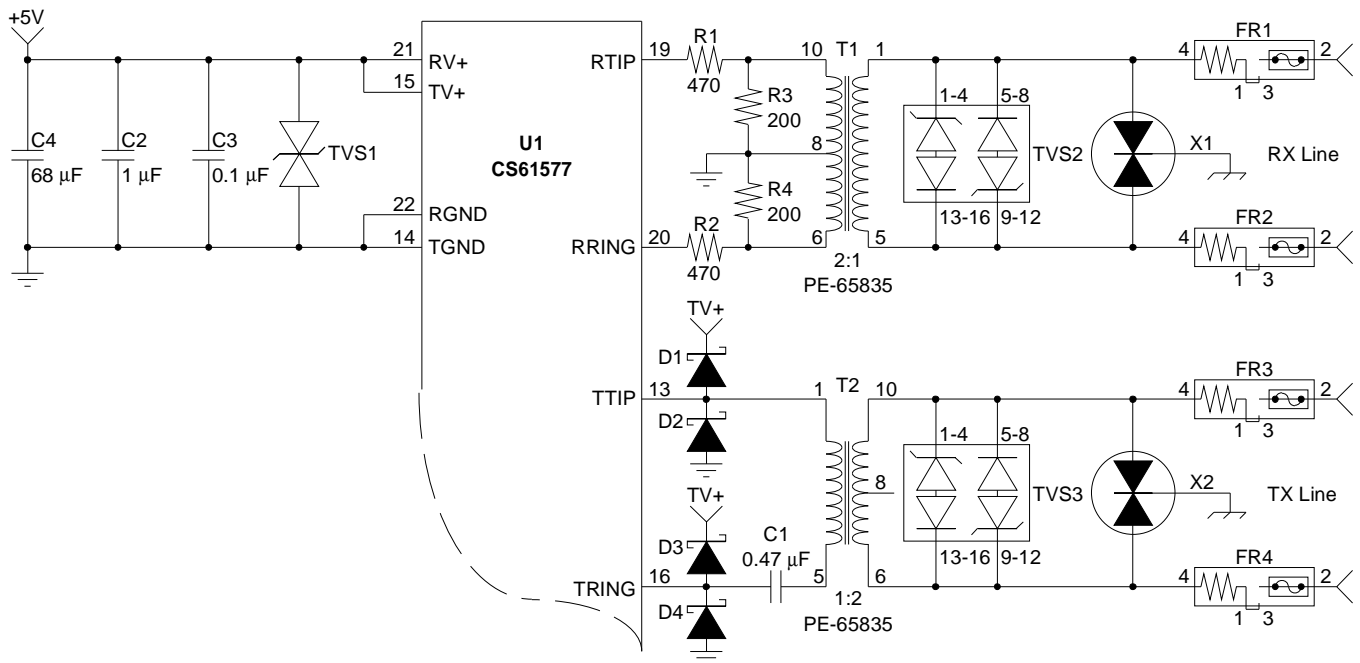

Component	Description	Part #	Manufacturer
TVS1	5 V, bi-directional TVS	SM05	Semtech
TVS2, TVS3	6 V, bi-directional, low capacitance TVS	LC01	Semtech
X1, X2	2800 V gas discharge tube		
FR1 - FR4	5.6 Ω thermal fuse/resistor	LFR-2-5.6-1	IRC, Inc.
D1 - D4	Schottky diode	11DQ04	International Rectifier

Figure 2. T1, Outside Line Protection Circuit.

primary protectors to shunt most of the surge current.

TVS1 is an SM05 bi-directional, 5 V transient voltage suppressor from Semtech which is used to clamp surges coupled onto the power supply by the Schottky diodes D1-D4.

T1, Inside Line Protection Circuit

The schematic in Figure 3 shows a T1, DSX-1 applications circuit for inside lines. This type of line protection may be used in customer prem-

ises equipment or telephone company equipment on ports which connect only to intra-building, metallic lines.

This circuit is designed to provide the intra-building lightning surge and 120 VAC power cross immunity required by Bellcore TR-NWT-001089.

This circuit provides current and voltage limiting for the TR-NWT-001089 metallic lightning surges. TVS2 is a low capacitance, avalanche TVS array from Protek Devices. This device contains two 12 V, bi-directional protectors rated

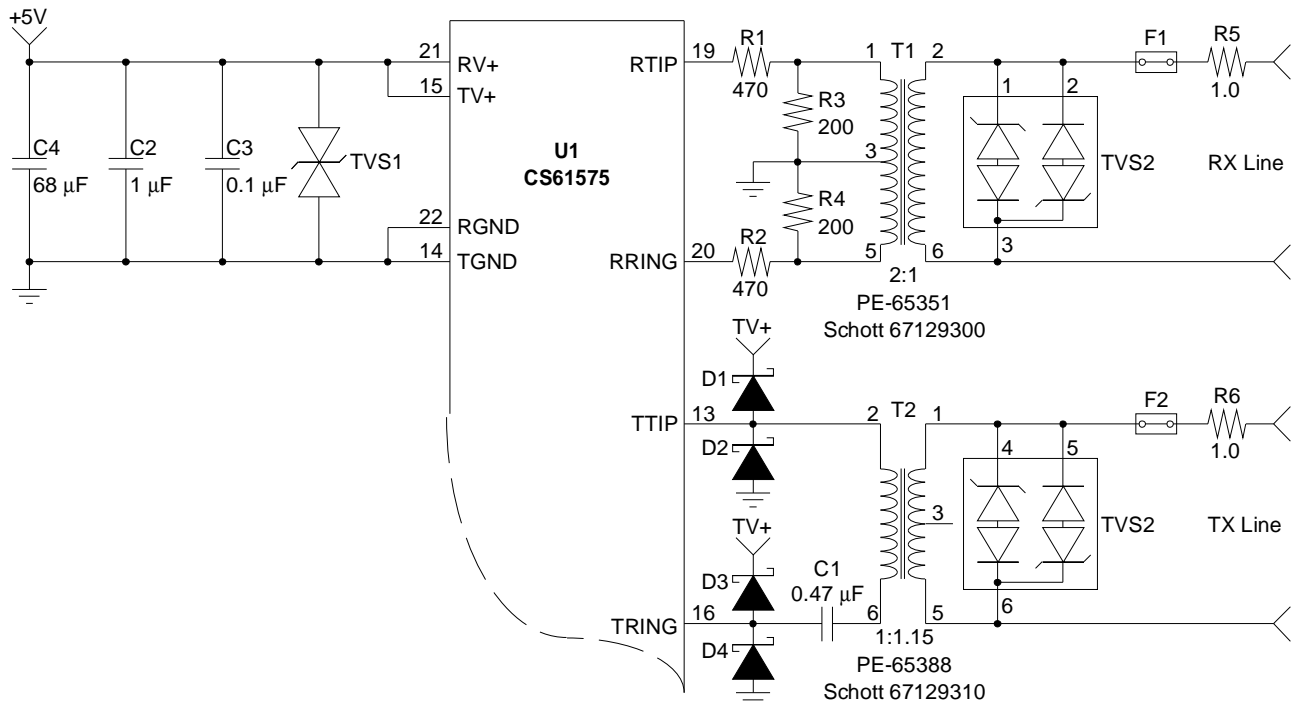

Component	Description	Part #	Manufacturer
TVS1	5 V, bi-directional TVS	SM05	Semtech
TVS2	12 V, bi-directional, low capacitance TVS	VSB06P12LC	Protek Devices
R5, R6	1.0 Ω, 2 W resistor		
F1 - F2	1.0 A time delay fuse	1.0A TR5-T	Wickmann USA
D1 - D4	Schottky diode	11DQ04	International Rectifier

Figure 3. T1, Inside Line Protection Circuit.

to handle the 2 x 10 μ s, 100A peak surge current required.

On both transmit and receive lines, time delay fuses, F1 and F2 provide the 120 V intra-building AC power cross protection required for customer premises equipment. The 1 Ω series resistors R5 and R6 provide surge current limiting to protect the fuses during a lightning surge. Since there is no chassis ground reference on the secondary (line side) of either the transmit or receive lines, all fault current flows from TIP to RING and only one fuse and series resistor is required for each line.

The 470 Ω series resistors R1 and R2 provide surge current limiting to protect the high impedance receiver RTIP and RRING input pins of the IC. R3 and R4 are 200 Ω resistors which provide the line side termination of 100 Ω .

On the transmitter output pins, the Schottky diodes D1 - D4 provide clamping within approximately 300 mV of the +5 V supply and ground without distorting the output pulse shape.

This circuit does not provide clamping during longitudinal (common mode) lightning surges to ground because the line transformers T1 and T2 are rated to withstand the 1500 Vpk surges required by TR-NWT-001089.

TVS1 is an SM05 bi-directional, 5 V transient voltage suppressor from Semtech which is used to clamp surges coupled onto the power supply by the Schottky diodes D1-D4.

E1 Protection Circuit

The schematic in Figure 4 shows a 75 Ω unbalanced E1 application circuit with line protection. Because no harmonized European standard has been formally adopted for E1 terminal equipment it is still necessary to consult the requirements imposed by specific countries.

CCITT K.20, IEC-801-5 and ETS 300-046-1 provide requirements which are similar to those imposed by many European countries. This circuit provides a general illustration which may readily be adapted to other requirements.

This circuit uses the avalanche diodes TVS2 - TVS5 together with the ultra-fast recovery diodes D5-D8 to provide low capacitance, bi-directional voltage limiting protection.

On both transmit and receive lines, time delay fuses, F1 and F2 provide current limiting protection for AC power cross or other steady-state faults. Some countries require the use of indicating fuses while others do not allow the use of fuses at all. In countries that do not allow fuses PTC resistors can be used to provide resettable protection. The 1 Ω series resistors R5 and R6 provide transient current limiting to protect the fuses during a lightning surge. Since the line connections are unbalanced, all fault current flows from TIP to RING and only one fuse and series resistor is required for each line.

The 470 Ω series resistors R1 and R2 provide surge current limiting to protect the high impedance receiver RTIP and RRING input pins of the IC. R3 and R4 are 150 Ω resistors which provide the line side termination of 75 Ω .

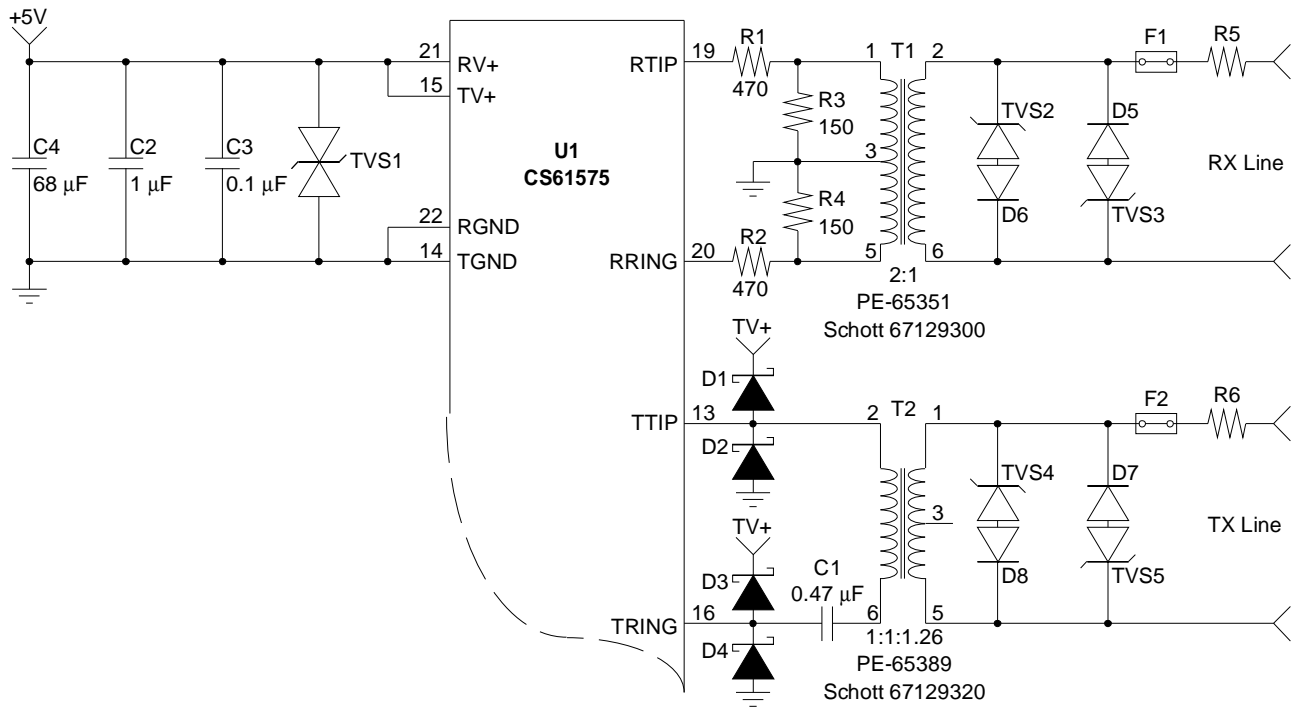

Component	Description	Part #	Manufacturer
TVS1	5 V, bi-directional TVS	SM05	Semtech
TVS2 - TVS5	6.5 V TVS	SMBJ6.5	Semtech
D5-D8	Ultra-fast recovery diode	SS8198	Semtech
R5, R6	1.0 Ω , 2 W resistor		
F1 - F2	1.0 A time delay fuse	TE5-T	Wickmann USA
D1 - D4	Schottky diode	11DQ04	International Rectifier

Figure 4. E1, 75 Ω Line Protection Circuit.

On the transmitter output pins, the Schottky diodes D1 - D4 provide clamping within approximately 300 mV of the +5 V supply and ground without distorting the output pulse shape.

TVS1 is an SM05 bi-directional, 5 V transient voltage suppressor from Semtech which is used to clamp surges coupled onto the power supply by the Schottky diodes D1-D4.

CONCLUSIONS

This application note has illustrated how to combine protection devices to realize practical secondary protection for the sensitive ICs on a T1/E1 line card. While these recommendations are intended to provide practical recommendations on how to satisfy FCC Part 68, UL1459, Bellcore TR-NWT-001089, CCITT K.20 and IEC 801-5 requirements, they should not replace careful design verification and testing to insure compliance with the appropriate specifications. The effectiveness of line protection will depend upon its specific implementation in a particular system. The following guidelines should be followed to insure optimum implementation.

1. T1/E1 line connections should be physically isolated from other components on the same circuit board. Provide adequate component spacing between line side components and chassis ground contact points to prevent arcing.

2. T1/E1 line connections should be electrically isolated from other components on the same circuit board. Careful attention to board layout should insure that no signal traces cross the transformer isolation barrier on any layer of the PCB. To insure this isolation, board area for line interface connections should be excluded from auto-routing and layout should be done by hand. No internal power or ground planes or signal traces should cross the isolation zone. The dielectric breakdown voltage between adjacent layers of a multi-layer PCB is much lower than that of a line coupling transformer.

3. Use appropriate size PCB traces for line side traces. Traces should be large enough to handle peak fault currents. Also keep in mind the thermal dissipation limits of the PCB and any connectors or cables in the signal path.

4. Board-level secondary protection should be designed to handle the energy that primary protectors let through and should allow most of the fault energy to be diverted by higher capacity primary protectors. Primary protection devices should not generally be used in line cards because of the limited energy handling capacity of printed circuit boards. It is more appropriate to shunt fault currents through large low impedance grounding links in distribution frames than to do so through line cards.

REFERENCES

1. **"Direct Connection to the Telephone Network"**, by Glen Dash and Isidor Straus, *Compliance Engineering 1993 Reference Guide*.
2. **"Bolts Out of the Blue"**, by Isidor Straus, *Compliance Engineering*, Winter 1991.
3. **"Selecting a Fuse Value"**, by Richard Nute, *Compliance Engineering*, Winter 1993.
4. **"Board-Level Protective Devices: Units Provide Extra Insurance Against Electronic Disaster"**, by Tom Ormond, *EDN*, August 20, 1992.
5. **"Protect Your Telecom System with Gas-Filled Surge Arresters"**, by Jurgen Boy, *Telephony*, December 2, 1992.
6. **"Testing ITE and Telecommunications Equipment for Immunity to Lightning Transients"**, Application Note 109, *Compliance Engineering*, 1992.
7. **"Testing Telecommunications Equipment to UL1459, Second Edition"**, Application Note 110, *Compliance Engineering*, 1992.
8. **"Gas-Discharge Systems Furnish Circuit Protection"**, by Nick Yapoujian, *EDN*, June 27, 1985.
9. **"Meeting UL1459 Requirements with Resettable Polymer PTCs"**, by David Samyn and Mark Elder, *Compliance Engineering*, Spring 1992.
10. **"The IEC's 801 Series: Coping with ESD, Transients and More"**, by Russell Pepe and Cathal Kavanaugh, *Compliance Engineering*, Summer 1992.
11. **"Protection of Electronic Circuits from Overvoltages"**, by Ronald B. Standler, Wiley & Sons, Inc., 1989.
12. **"Product Safety for Telecommunications Equipment"**, by Louis Feudi, *Compliance Engineering 1993 Reference Guide*.
13. **"Transient Voltage Suppressor Types and Applications"**, by O. Melville Clark, *Power Conversion & Intelligent Motion*, November 1990.
14. **Part 68- Connection of Terminal Equipment to the Telephone Network**, U.S. Federal Communications Commission, October 1985.
15. **UL1459: Standard for Telephone Equipment, Second Edition**, Underwriters Laboratories, October 1, 1990.
16. **TR-EOP-000001: Lightning, Radio Frequency and 60 Hz Disturbances at the Bell Operating Company Network Interface**, Bell Communications Research, Issue 2, June 1987.
17. **TR-NWT-001089: Electromagnetic Compatibility and Electrical Safety Generic Criteria for Network Telecommunication Equipment**, Bell Communications Research, Issue 1, October 1991.