

Description

The SMDJ Series are designed specifically to protect sensitive electronic equipment from voltage transients induced by lightning and other transient voltage events.

Unidirectional

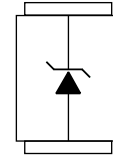

Bidirectional

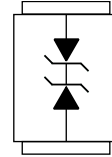

Feature

- For surface mounted applications in order to optimize board space
- Low profile package
- Low inductance
- Glass passivated chip
- Very fast response time
- Excellent clamping capability
- Typical I_D less than 1UA at V_{WM}
- 3000W peak pulse power capability with a 10/1000 us Waveform

Applications

Electrical characteristics apply in both directions.

Mechanical Characteristics

- Case: JEDEC DO-214AB molded plastic body over glass passivated chip
- Terminals: Solder plated, solderable per MIL-STD-750 Method 2026
- Polarity: For uni-directional types the band by laser denotes the cathode, which is positive with respect to the anode under normal TVS operation

Major Rating and Characteristics

Major Rating and Characteristics	
P_{PPM}	3000W
V_{RRM}	5V to 220V
I_{FSM}	200A
T_{jmax}	150°C

Maximum Ratings and Thermal Characteristics ($T_A=25^\circ\text{C}$ unless otherwise noted)

Parameter	Symbol	Value	Unit
Peak Pulse Power Dissipation with a 10/1000 μs waveform (see fig.1)	P_{PPM}	3000	W
Peak pulse current with a waveform (see fig.3, single pulse)	I_{PPM}	See Next Table	A
Peak Forward Surge Current 8.3ms Single Half Sine-Wave uni-directional only	I_{FSM}	200	A
Typical thermal resistance, Junction to ambient ⁽¹⁾	$R_{\theta JA}$	75	°C/W
Typical thermal resistance , Junction to Lead ⁽¹⁾	$R_{\theta JL}$	15	°C/W
Operation Junction and Storage Temperature Range	T_J, T_{STG}	-55 to 150	°C

Notes:

1. Mounted on P.C.B. with 0.32X0.32" (8.0X8.0 mm) copper pad areas.

Electrical characteristics

Part Number (Uni)	Part Number (Bi)	Reverse Stand off Voltage V_{WM} (V)	Breakdown Voltage V_{BR} @ $I_T^{(1)}$ V_{BR} (V)		Test Current I_T (mA)	Maximum Clamping Voltage V_C @ I_{PPM} (V)	Maximum Peak Pulse Surge Current I_{PPM} (A) ⁽²⁾	Maximum Reverse Leakage I_D @ V_{WM} (μ A)
			MIN	MAX				
SMDJ5.0A	SMDJ5.0CA	5	6.4	7	10	9.2	326.1	800
SMDJ6.0A	SMDJ6.0CA	6	6.67	7.37	10	10.3	291.3	800
SMDJ6.5A	SMDJ6.5CA	6.5	7.22	7.98	10	11.2	267.9	500
SMDJ7.0A	SMDJ7.0CA	7	7.78	8.6	10	12	250	200
SMDJ7.5A	SMDJ7.5CA	7.5	8.33	9.21	1	12.9	232.6	100
SMDJ8.0A	SMDJ8.0CA	8	8.89	9.83	1	13.6	220.6	50
SMDJ8.5A	SMDJ8.5CA	8.5	9.44	10.4	1	14.4	208.3	20
SMDJ9.0A	SMDJ9.0CA	9	10	11.1	1	15.4	194.8	10
SMDJ10A	SMDJ10CA	10	11.1	12.3	1	17	176.5	5
SMDJ11A	SMDJ11CA	11	12.2	13.5	1	18.2	164.8	2
SMDJ12A	SMDJ12CA	12	13.3	14.7	1	19.9	150.8	2
SMDJ13A	SMDJ13CA	13	14.4	15.9	1	21.5	139.5	2
SMDJ14A	SMDJ14CA	14	15.6	17.2	1	23.2	129.3	2
SMDJ15A	SMDJ15CA	15	16.7	18.5	1	24.4	123	2
SMDJ16A	SMDJ16CA	16	17.8	19.7	1	26	115.4	2
SMDJ17A	SMDJ17CA	17	18.9	20.9	1	27.6	108.7	2
SMDJ18A	SMDJ18CA	18	20	22.1	1	29.2	102.7	2
SMDJ20A	SMDJ20CA	20	22.2	24.5	1	32.4	92.6	2
SMDJ22A	SMDJ22CA	22	24.4	26.9	1	35.5	84.5	2
SMDJ24A	SMDJ24CA	24	26.7	29.5	1	38.9	77.1	2
SMDJ26A	SMDJ26CA	26	28.9	31.9	1	42.1	71.3	2
SMDJ28A	SMDJ28CA	28	31.1	34.4	1	45.4	66.1	2
SMDJ30A	SMDJ30CA	30	33.3	36.8	1	48.4	62	2
SMDJ33A	SMDJ33CA	33	36.7	40.6	1	53.3	56.3	2
SMDJ36A	SMDJ36CA	36	40	44.2	1	58.1	51.6	2
SMDJ40A	SMDJ40CA	40	44.4	49.1	1	64.5	46.5	2
SMDJ43A	SMDJ43CA	43	47.8	52.8	1	69.4	43.2	2
SMDJ45A	SMDJ45CA	45	50	55.3	1	72.7	41.3	2

Part Number (Uni)	Part Number (Bi)	Reverse Stand off Voltage V_{WM} (V)	Breakdown Voltage V_{BR} @ $I_T^{(1)}$ V_{BR} (V)		Test Current I_T (mA)	Maximum Clamping Voltage V_C @ I_{PPM} (V)	Maximum Peak Pulse Surge Current I_{PPM} (A)	Maximum Reverse Leakage I_D @ V_{WM} (μ A)
			MIN	MAX				
SMDJ48A	SMDJ48CA	48	53.3	58.9	1	77.4	38.8	2
SMDJ50A	SMDJ50CA	50	56.2	61.2	1	80.7	37.2	2
SMDJ51A	SMDJ51CA	51	56.7	62.7	1	82.4	36.4	2
SMDJ54A	SMDJ54CA	54	60	66.3	1	87.1	34.4	2
SMDJ58A	SMDJ58CA	58	64.4	71.2	1	93.6	32.1	2
SMDJ60A	SMDJ60CA	60	66.7	73.7	1	96.8	31	2
SMDJ64A	SMDJ64CA	64	71.1	78.6	1	103	29.1	2
SMDJ70A	SMDJ70CA	70	77.8	86	1	113	26.5	2
SMDJ75A	SMDJ75CA	75	83.3	92.1	1	121	24.8	2
SMDJ78A	SMDJ78CA	78	86.7	95.8	1	126	23.8	2
SMDJ85A	SMDJ85CA	85	94.4	104	1	137	21.9	2
SMDJ90A	SMDJ90CA	90	100	111	1	146	20.5	2
SMDJ100A	SMDJ100CA	100	111	123	1	162	18.5	2
SMDJ110A	SMDJ110CA	110	122	135	1	177	16.9	2
SMDJ120A	SMDJ120CA	120	133	147	1	193	15.5	2
SMDJ130A	SMDJ130CA	130	144	159	1	209	14.4	2
SMDJ150A	SMDJ150CA	150	167	185	1	243	12.3	2
SMDJ160A	SMDJ160CA	160	178	197	1	259	11.6	2
SMDJ170A	SMDJ170CA	170	189	209	1	275	10.9	2
SMDJ180A	SMDJ180CA	180	200	221	1	292	10.3	2
SMDJ220A	SMDJ220CA	220	244	270	1	356	8.4	2

Notes:

1. Pulse test : $T_p \leq 50$ ms
2. Surge current waveform Per Fig.3 and derate Per Fig.2

Ratings and Characteristic Curves $T_A=25^\circ\text{C}$ unless otherwise noted

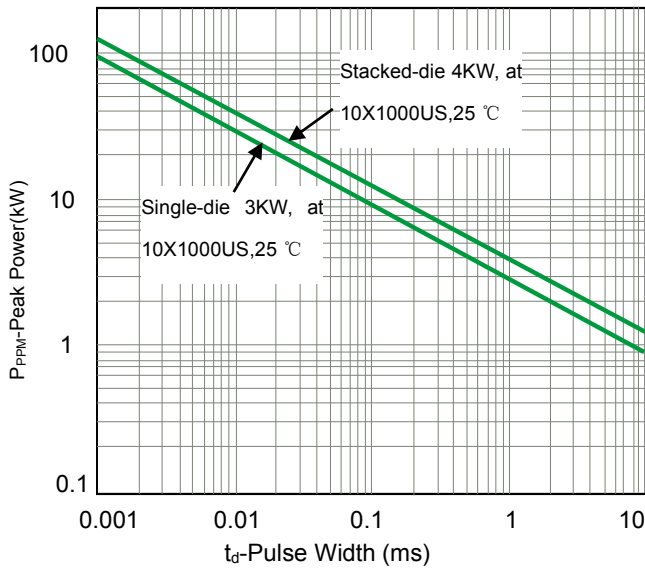

Figure 1-Peak Pulse Power Rating

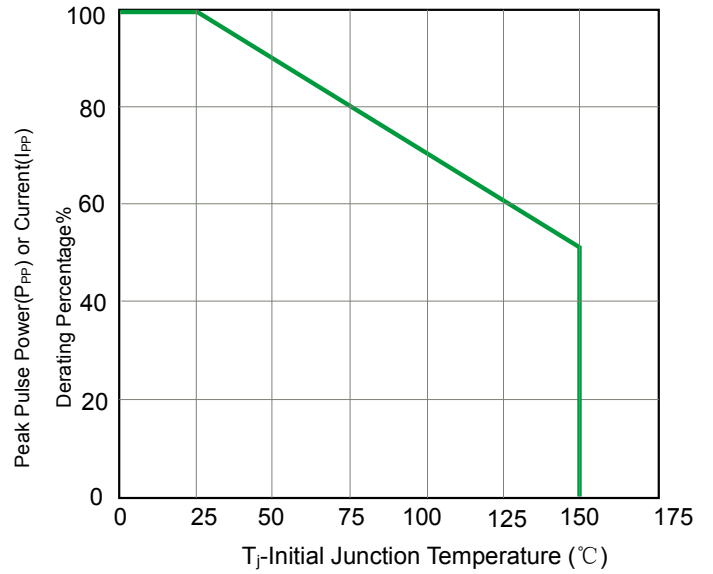

Figure 2-Peak Pulse Derating Curve

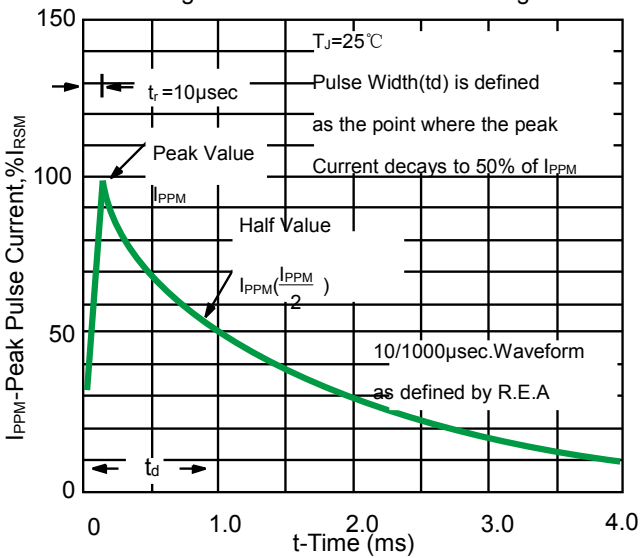

Figure 3-Pulse Waveform

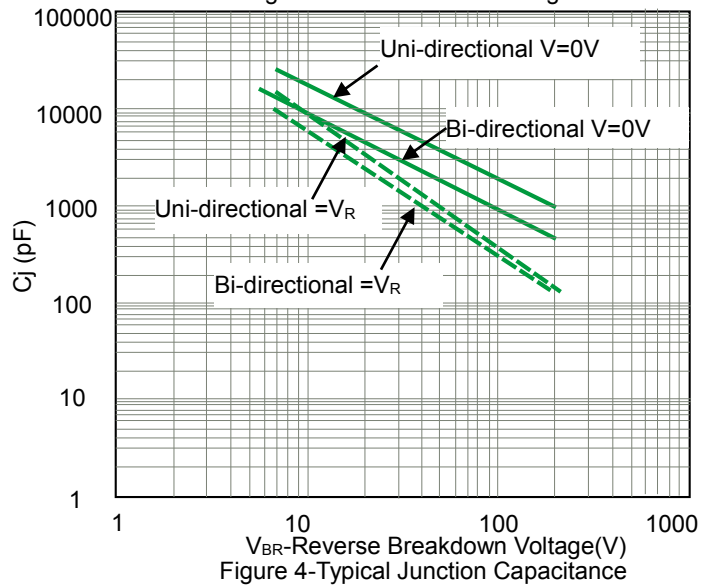

Figure 4-Typical Junction Capacitance

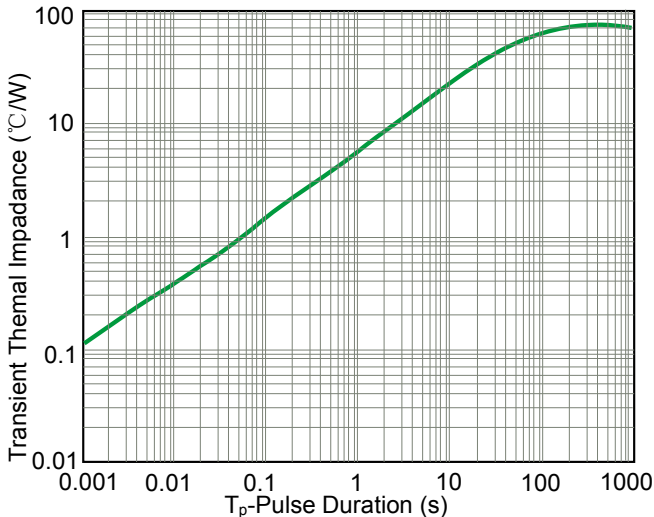

Figure 5-Typical Transient Thermal Impedance

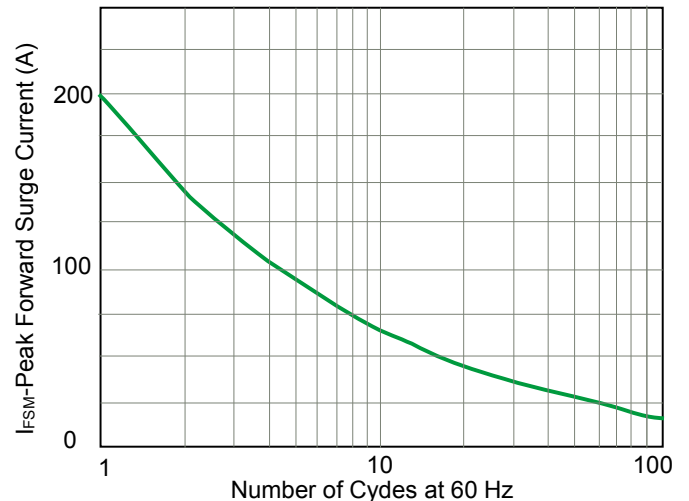
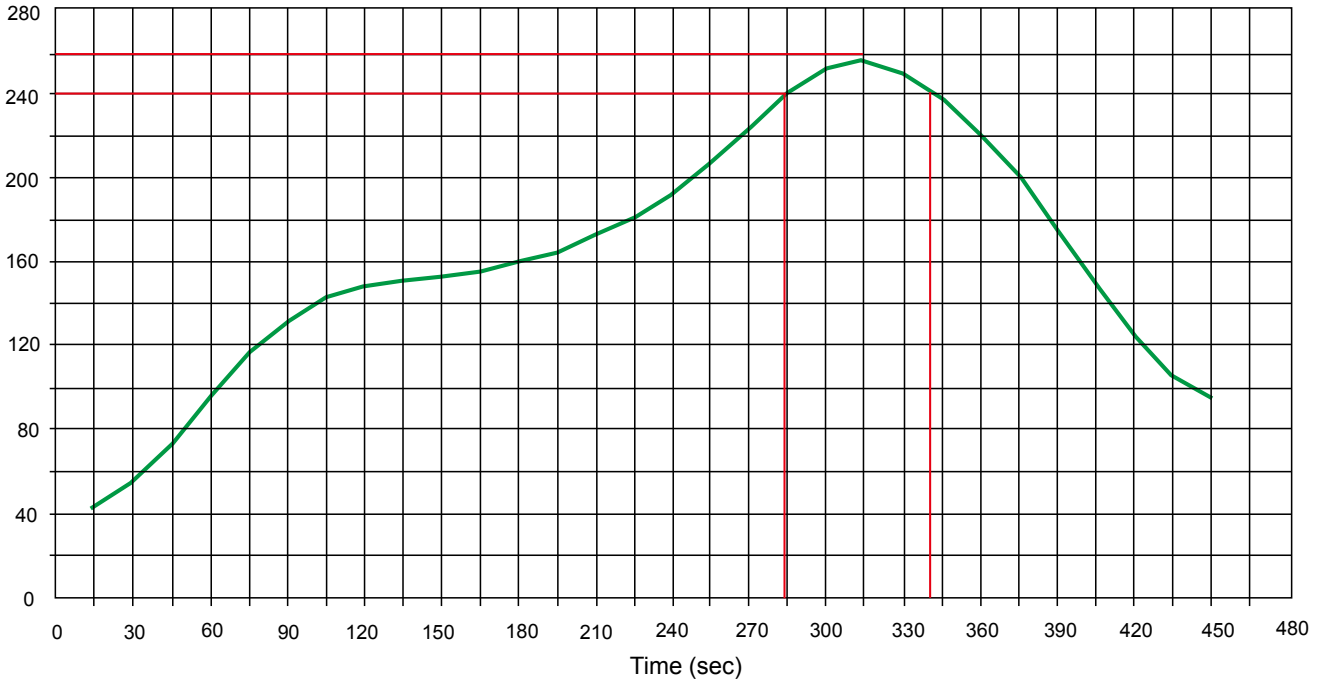

Figure 6-Maximum Non-Repetitive Peak Forward Surge Current Uni-Directional Only

Solder Reflow Recommendation

Peak Temp=257°C, Ramp Rate=0.802deg. °C/sec



Product dimension (DO-214AB)

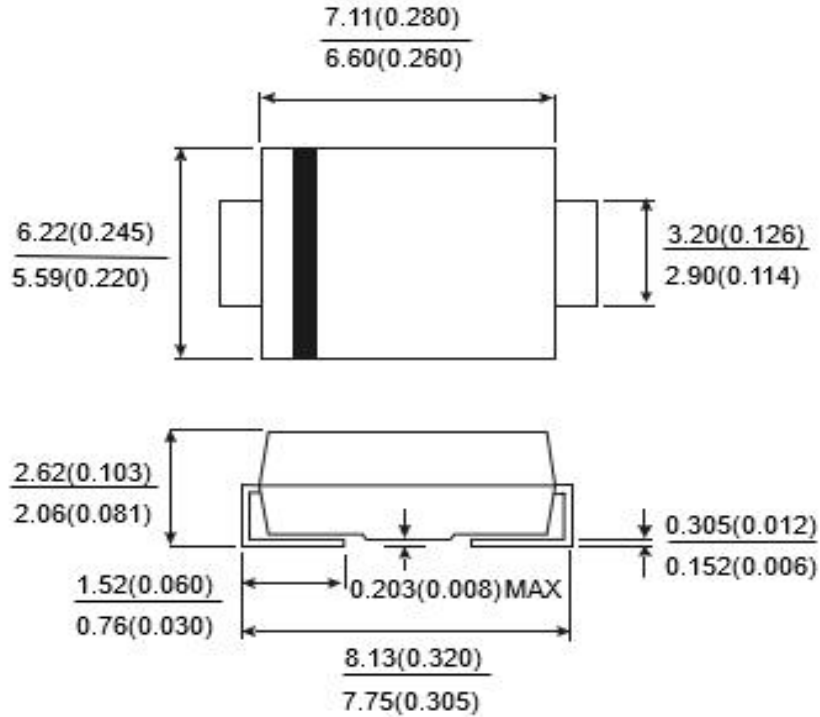

Dimensions in millimeters and (inches)

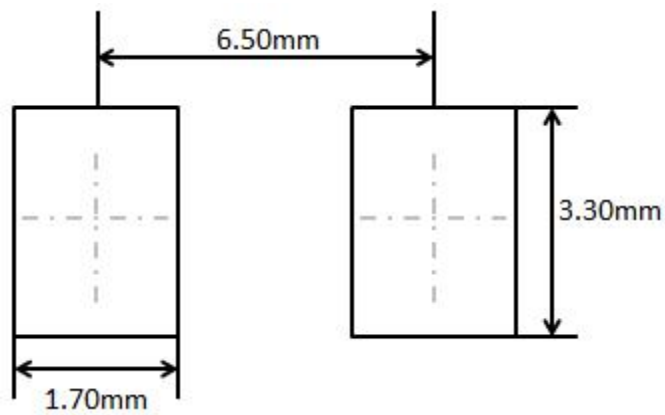

Suggested PCB Layout

Ordering information

Device	Package	Shipping
SMDJ Series	DO-214AB(Pb-Free)	3000 / Tape & Reel

IMPORTANT NOTICE

 and **Prisemi**[®] are registered trademarks of **Prisemi Electronics Co., Ltd** (Prisemi). Prisemi reserves the right to make changes without further notice to any products herein. Prisemi makes no warranty, representation or guarantee regarding the suitability of its products for any particular purpose, nor does Prisemi assume any liability arising out of the application or use of any product or circuit, and specifically disclaims any and all liability, including without limitation special, consequential or incidental damages. "Typical" parameters which may be provided in Prisemi data sheets and/or specifications can and do vary in different applications and actual performance may vary over time. All operating parameters, including "Typicals" must be validated for each customer application by customer's technical experts. Prisemi does not convey any license under its patent rights nor the rights of others. The products listed in this document are designed to be used with ordinary electronic equipment or devices, Should you intend to use these products with equipment or devices which require an extremely high level of reliability and the malfunction of with would directly endanger human life (such as medical instruments, aerospace machinery, nuclear-reactor controllers, fuel controllers and other safety devices), please be sure to consult with our sales representative in advance.

Website: <http://www.prisemi.com>

For additional information, please contact your local Sales Representative.

©Copyright 2009, Prisemi Electronics

 **Prisemi**[®] is a registered trademark of Prisemi Electronics.

All rights are reserved.