

# SFM11-MH THRU SFM18-MH

## List

List.....	1
Package outline.....	2
Features.....	2
Mechanical data.....	2
Maximum ratings and Electrical characteristics .....	2
Rating and characteristic curves.....	3
Pinning information.....	4
Marking.....	4
Suggested solder pad layout.....	4
Packing information.....	5
Reel packing.....	6
Suggested thermal profiles for soldering processes.....	6
High reliability test capabilities.....	7

# SFM11-MH THRU SFM18-MH

## 1.0A Surface Mount Super Fast Rectifiers-50-600V

### Features

- Batch process design, excellent power dissipation offers better reverse leakage current and thermal resistance
- Low profile surface mounted application in order to optimize board space
- Tiny plastic SMD package
- High current capability
- Super fast recovery time for switching mode application
- High surge current capability
- Glass passivated chip junction
- Lead-free parts meet RoHS requirements
- Suffix "-H" indicates Halogen free parts, ex. SFM11-MH-H

### Mechanical data

- Epoxy : UL94-V0 rated flame retardant
- Case : Molded plastic, SOD-123H
- Terminals :Plated terminals, solderable per MIL-STD-750, Method 2026
- Polarity : Indicated by cathode band
- Mounting Position : Any
- Weight : Approximated 0.011 gram

### Package outline

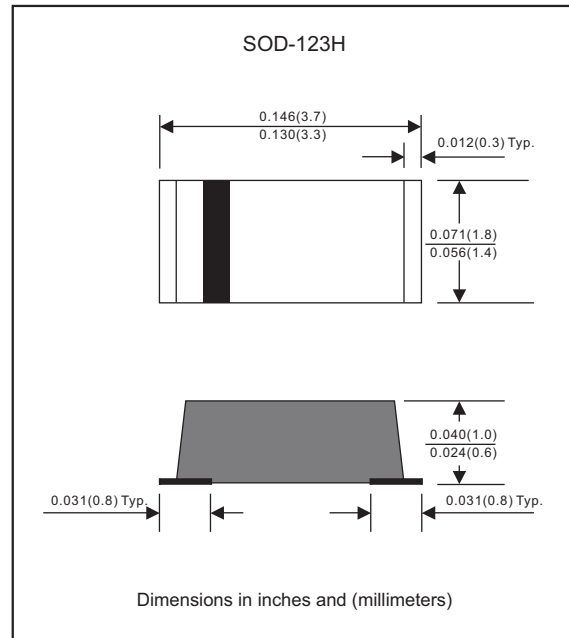

### Maximum ratings and Electrical characteristics (AT $T_A=25^{\circ}\text{C}$ unless otherwise noted)

PARAMETER	CONDITIONS	Symbol	MIN.	TYP.	MAX.	UNIT
Forward rectified current	See Fig.2	$I_o$			1.0	A
Forward surge current	8.3ms single half sine-wave (JEDEC methode)	$I_{FSM}$			25	A
Reverse current	$V_R = V_{RRM} T_J = 25^{\circ}\text{C}$	$I_R$			5.0	$\mu\text{A}$
	$V_R = V_{RRM} T_J = 125^{\circ}\text{C}$				100	
Thermal resistance	Junction to ambient	$R_{\theta JA}$		52		$^{\circ}\text{C/W}$
	Junction to case	$R_{\theta JC}$		36		
Diode junction capacitance	f=1MHz and applied 4V DC reverse voltage	$C_J$		10		pF
Storage temperature		$T_{STG}$	-65		+175	$^{\circ}\text{C}$

SYMBOLS	$V_{RRM}^{*1}$ (V)	$V_{RMS}^{*2}$ (V)	$V_R^{*3}$ (V)	$V_F^{*4}$ (V)	$t_{rr}^{*5}$ (ns)	Operating temperature $T_J, (^{\circ}\text{C})$
SFM11-MH	50	35	50	0.95	35	-55 to +150
SFM12-MH	100	70	100			
SFM13-MH	150	105	150			
SFM14-MH	200	140	200			
SFM15-MH	300	210	300	1.25	35	-55 to +150
SFM16-MH	400	280	400			
SFM17-MH	500	350	500			
SFM18-MH	600	420	600	1.70	35	-55 to +150

- \*1 Repetitive peak reverse voltage
- \*2 RMS voltage
- \*3 Continuous reverse voltage
- \*4 Maximum forward voltage@ $I_F=1.0\text{A}$
- \*5 Maximum Reverse recovery time, note 1

Note 1. Reverse recovery time test condition,  $I_F=0.5\text{A}$ ,  $I_R=1.0\text{A}$ ,  $I_{RR}=0.25\text{A}$

# Rating and characteristic curves (SFM11-MH THRU SFM18-MH)

FIG.1-TYPICAL FORWARD CHARACTERISTICS

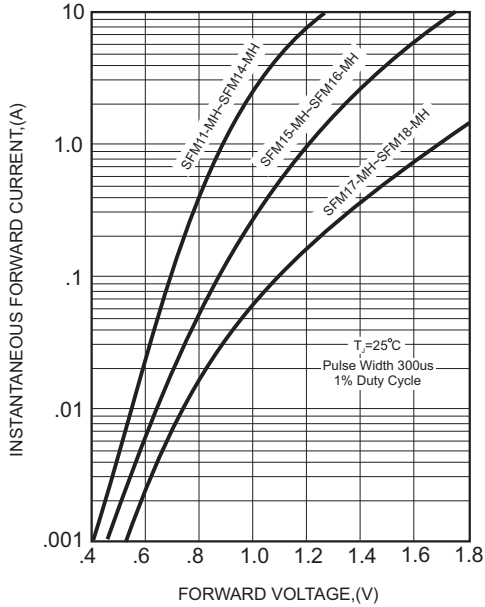

FIG.2-TYPICAL FORWARD CURRENT DERATING CURVE

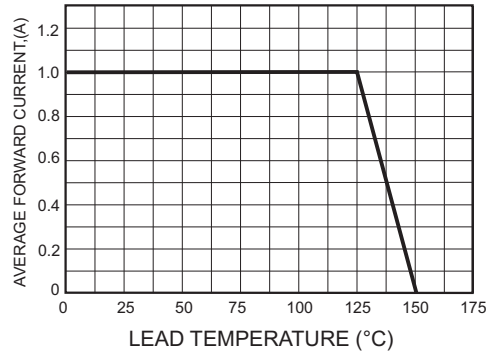

FIG.4-MAXIMUM NON-REPETITIVE FORWARD SURGE CURRENT

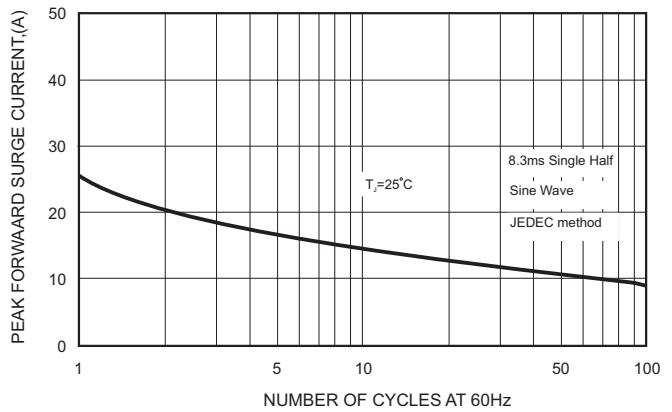
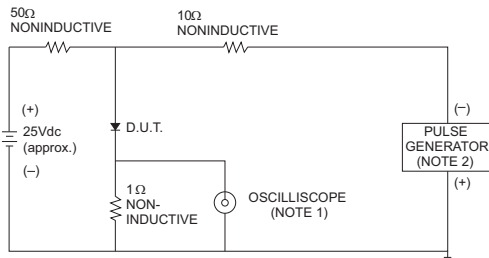

FIG.3- TEST CIRCUIT DIAGRAM AND REVERSE RECOVERY TIME CHARACTERISTICS



- NOTES: 1. Rise Time = 7ns max., Input Impedance = 1 megohm, 22pF.  
2. Rise Time = 10ns max., Source Impedance = 50 ohms.

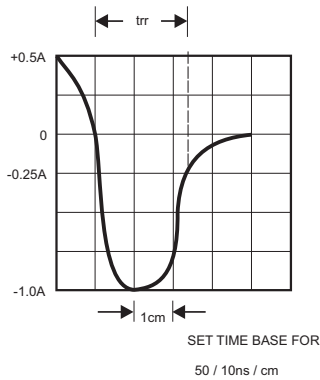
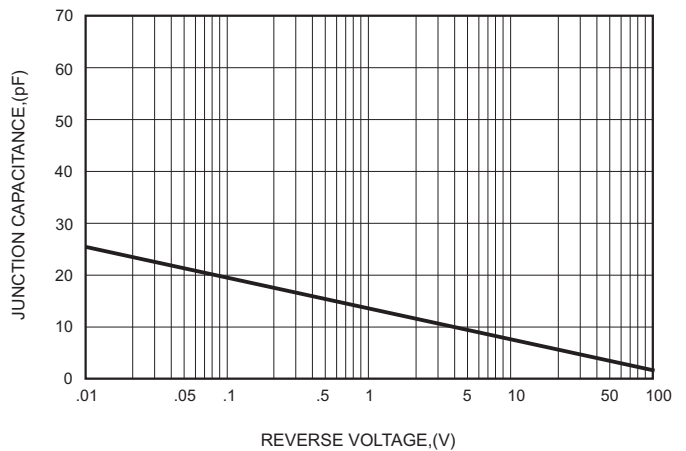

FIG.5-TYPICAL JUNCTION CAPACITANCE



# SFM11-MH THRU SFM18-MH

## Pinning information

Pin	Simplified outline	Symbol
Pin1 cathode Pin2 anode		

## Marking

Type number	Marking code
SFM11-MH	S1
SFM12-MH	S2
SFM13-MH	S3
SFM14-MH	S4
SFM15-MH	S5
SFM16-MH	S6
SFM17-MH	S7
SFM18-MH	S8

## Suggested solder pad layout

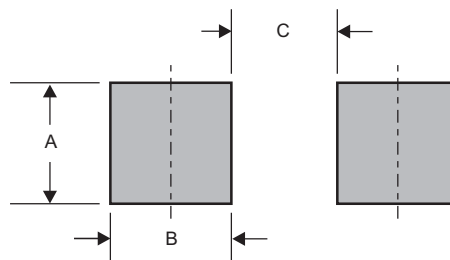

Dimensions in inches and (millimeters)

PACKAGE	A	B	C
SOD-123H	0.071 (1.80)	0.051 (1.30)	0.067 (1.70)

# SFM11-MH THRU SFM18-MH

## Packing information

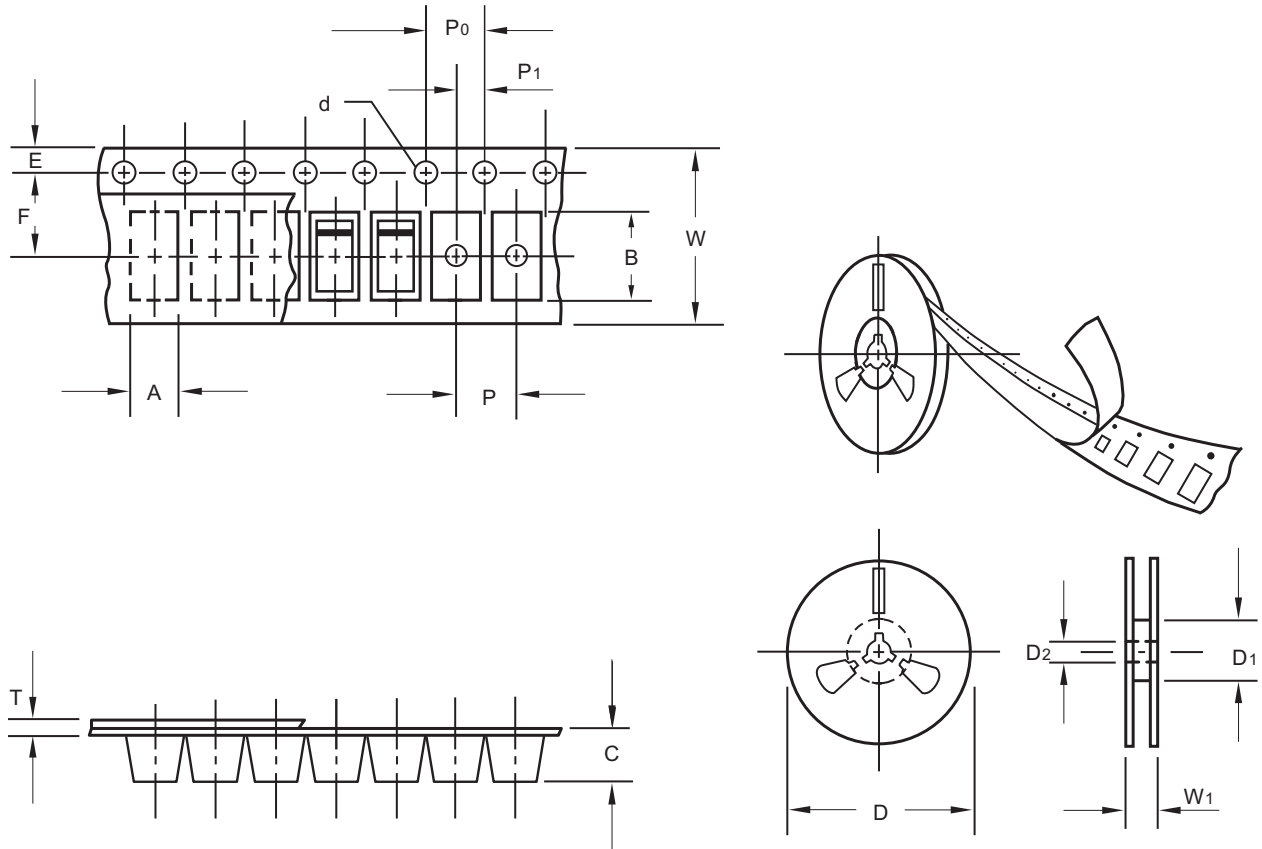

unit:mm

Item	Symbol	Tolerance	SOD-123H
Carrier width	A	0.1	2.00
Carrier length	B	0.1	3.85
Carrier depth	C	0.1	1.10
Sprocket hole	d	0.1	1.50
13" Reel outside diameter	D	2.0	-
13" Reel inner diameter	D1	min	-
7" Reel outside diameter	D	2.0	178.00
7" Reel inner diameter	D1	min	62.00
Feed hole diameter	D2	0.5	13.00
Sprocket hole position	E	0.1	1.75
Punch hole position	F	0.1	3.50
Punch hole pitch	P	0.1	4.00
Sprocket hole pitch	P0	0.1	4.00
Embossment center	P1	0.1	2.00
Overall tape thickness	T	0.1	0.23
Tape width	W	0.3	8.00
Reel width	W1	1.0	11.40

Note: Devices are packed in accordance with EIA standard RS-481-A and specifications listed above.

# SFM11-MH THRU SFM18-MH

## Reel packing

PACKAGE	REEL SIZE	REEL (pcs)	COMPONENT SPACING (m/m)	BOX (pcs)	INNER BOX (m/m)	REEL DIA, (m/m)	CARTON SIZE (m/m)	CARTON (pcs)	APPROX. GROSS WEIGHT (kg)
SOD-123H	7"	3,000	4.0	30,000	183*123*183	178	382*257*387	240,000	9.0

## Suggested thermal profiles for soldering processes

- 1.Storage environment: Temperature=5°C~40°C Humidity=55%±25%
- 2.Reflow soldering of surface-mount devices

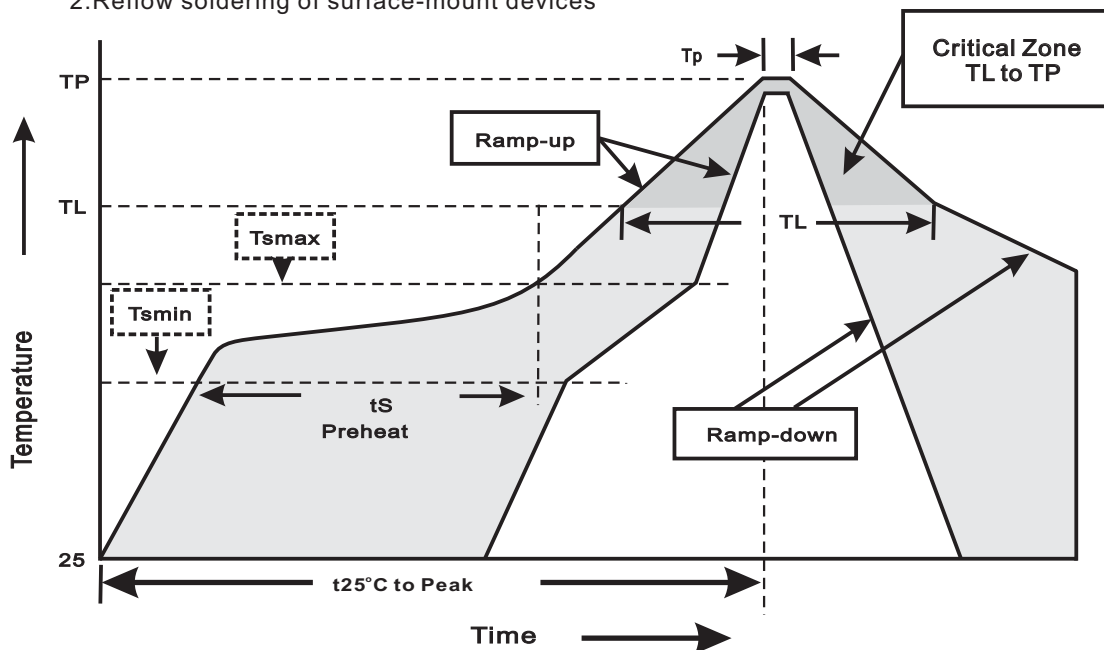

### 3.Reflow soldering

Profile Feature	Soldering Condition
Average ramp-up rate(TL to TP)	<3°C/sec
Preheat -Temperature Min(Tsmin) -Temperature Max(Tsmax) -Time(min to max)(ts)	150°C 200°C 60~120sec
Tsmax to TL -Ramp-upRate	<3°C/sec
Time maintained above: -Temperature(TL) -Time(tL)	217°C 60~260sec
Peak Temperature(TP)	255°C-0/+5°C
Time within 5°C of actual Peak Temperature(tP)	10~30sec
Ramp-down Rate	<6°C/sec
Time 25°C to Peak Temperature	<6minutes

**SFM11-MH THRU SFM18-MH****High reliability test capabilities**

Item Test	Conditions	Reference
1. Solder Resistance	at 260±5°C for 10±2sec.	MIL-STD-750D METHOD-2031
2. Solderability	at 245±5°C for 5 sec.	MIL-STD-202F METHOD-208
3. High Temperature Reverse Bias	$V_R=80\%$ rate at $T_J=150^\circ\text{C}$ for 168 hrs.	MIL-STD-750D METHOD-1038
4. Forward Operation Life	Rated average rectifier current at $T_A=25^\circ\text{C}$ for 500hrs.	MIL-STD-750D METHOD-1027
5. Intermittent Operation Life	$T_A = 25^\circ\text{C}$ , $I_F = I_O$ On state: power on for 5 min. off state: power off for 5 min. on and off for 500 cycles.	MIL-STD-750D METHOD-1036
6. Pressure Cooker	15P <sub>SIG</sub> at $T_A=121^\circ\text{C}$ for 4 hrs.	JESD22-A102
7. Temperature Cycling	-55°C to +125°C dwelled for 30 min. and transferred for 5min. total 10 cycles.	MIL-STD-750D METHOD-1051
8. Forward Surge	8.3ms single half sine-wave , one surge.	MIL-STD-750D METHOD-4066-2
9. Humidity	at $T_A=85^\circ\text{C}$ , RH=85% for 1000hrs.	MIL-STD-750D METHOD-1021
10. High Temperature Storage Life	at 175°C for 1000 hrs.	MIL-STD-750D METHOD-1031