

● Applications

Inverter, Interface, Driver

● Features

- 1) Built-in bias resistors enable the configuration of an inverter circuit without connecting external input resistors (see equivalent circuit).
- 2) The bias resistors consist of thin-film resistors with complete isolation to allow positive biasing of the input. They also have the advantage of almost completely eliminating parasitic effects.
- 3) Only the on/off conditions need to be set for operation, making the device design easy.

- We declare that the material of product compliance with RoHS requirements.

● Absolute maximum ratings (Ta=25°C)

Parameter	Symbol	Limits	Unit
Collector-base voltage	V_{CB0}	-50	V
Collector-emitter voltage	V_{CE0}	-50	V
Emitter-base voltage	V_{EB0}	-5	V
Collector current	I_C	-100	mA
Collector power dissipation	P_C	200	mW
Junction temperature	T_j	150	°C
Storage temperature	T_{stg}	-55 to +150	°C

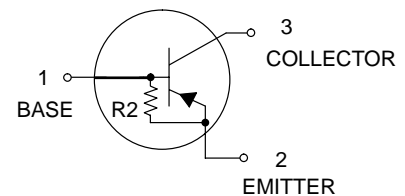
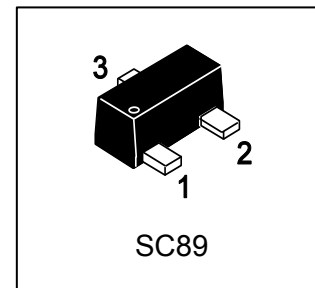

DEVICE MARKING AND RESISTOR VALUES

Device	Marking	R1 (K)	R2 (K)	Shipping
DTA115GET1G	Q4	-	100	3000/Tape & Reel
DTA115GET3G	Q4	-	100	10000/Tape & Reel

● Electrical characteristics (Ta=25°C)

Parameter	Symbol	Min.	Typ.	Max.	Unit	Conditions
Collector-base breakdown voltage	BV_{CB0}	-50	-	-	V	$I_C = -50 \mu A$
Collector-emitter breakdown voltage	BV_{CE0}	-50	-	-	V	$I_C = -1 mA$
Emitter-base breakdown voltage	BV_{EB0}	-5	-	-	V	$I_E = -72 \mu A$
Collector cutoff current	I_{CB0}	-	-	-0.5	μA	$V_{CB} = -50 V$
Emitter cutoff current	I_{EB0}	-30	-	-58	μA	$V_{EB} = -4 V$
Collector-emitter saturation voltage	$V_{CE(sat)}$	-	-	-0.3	V	$I_C = -5 mA, I_B = -0.25 mA$
DC current transfer ratio	h_{FE}	82	-	-	-	$I_C = -5 mA, V_{CE} = -5 V$
Emitter-base resistance	R	70	100	130	k Ω	-
Transition frequency	f_T	-	250	-	MHz	$V_{CE} = -10 V, I_E = 5 mA, f = 100 MHz$ *

* Transition frequency of the device.

● **Electrical characteristic curves**

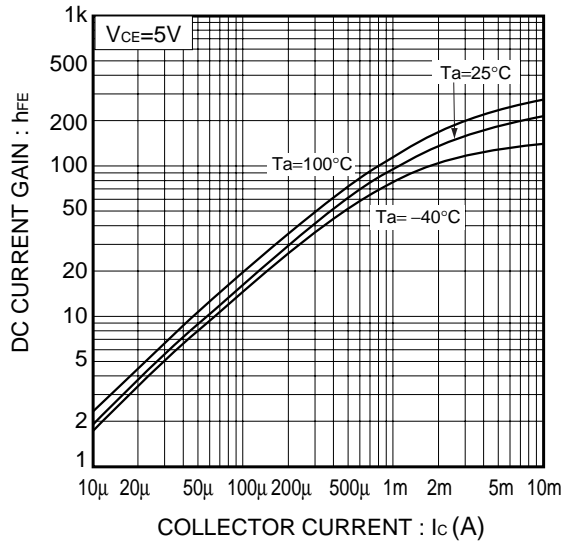

Fig.1 DC current gain vs. Collector current

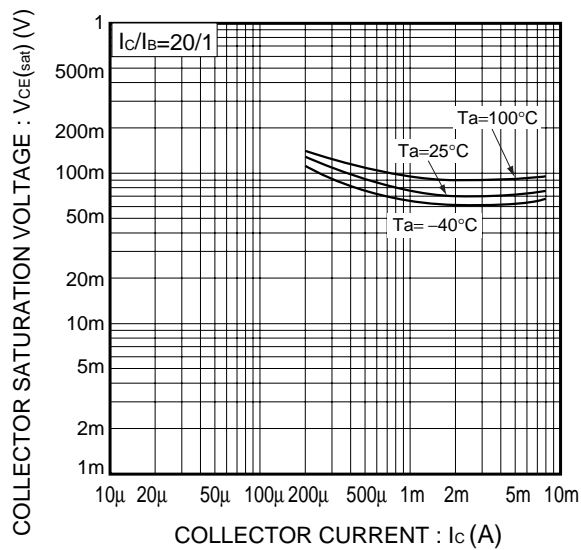
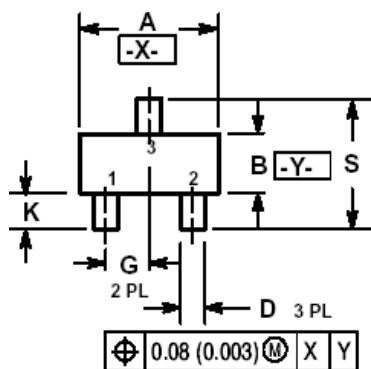

Fig.2 Collector-Emitter saturation voltage vs. Collector current

SC-89



NOTES:

1. DIMENSIONING AND TOLERANCING PER ANSI Y14.5M, 1982.
2. CONTROLLING DIMENSION: MILLIMETERS
3. MAXIMUM LEAD THICKNESS INCLUDES LEAD FINISH THICKNESS. MINIMUM LEAD THICKNESS IS THE MINIMUM THICKNESS OF BASE MATERIAL.
4. 463C-01 OBSOLETE, NEW STANDARD 463C-02.

DIM	MILLIMETERS			INCHES		
	MIN	NOM	MAX	MIN	NOM	MAX
A	1.50	1.60	1.70	0.059	0.063	0.067
B	0.75	0.85	0.95	0.030	0.034	0.040
C	0.60	0.70	0.80	0.024	0.028	0.031
D	0.23	0.28	0.33	0.009	0.011	0.013
G	0.50 BSC			0.020 BSC		
H	0.53 REF			0.021 REF		
J	0.10	0.15	0.20	0.004	0.006	0.008
K	0.30	0.40	0.50	0.012	0.016	0.020
L	1.10 REF			0.043 REF		
M	---	---	10 °	---	---	10 °
N	---	---	10 °	---	---	10 °
S	1.50	1.60	1.70	0.059	0.063	0.067

