

FM220-MH THRU FM2200-MH

List

List.....	1
Package outline.....	2
Features.....	2
Mechanical data.....	2
Maximum ratings and Electrical characteristics	2
Rating and characteristic curves.....	3
Pinning information.....	4
Marking.....	4
Suggested solder pad layout.....	4
Packing information.....	5
Reel packing.....	6
Suggested thermal profiles for soldering processes.....	6
High reliability test capabilities.....	7

FM220-MH THRU FM2200-MH

2.0A Surface Mount Schottky Barrier Rectifiers 20V-200V

Features

- Batch process design, excellent power dissipation offers better reverse leakage current and thermal resistance
- Low profile surface mounted application in order to optimize board space
- Tiny plastic SMD package
- Low power loss, high efficiency
- High current capability, low forward voltage drop
- High surge capability
- Guardring for overvoltage protection
- Ultra high-speed switching
- Silicon epitaxial planar chip, metal silicon junction
- Lead-free parts meet RoHS requirements
- Suffix "-H" indicates Halogen free parts, ex. FM220-MH-H

Mechanical data

- Epoxy : UL94-V0 rated flame retardant
- Case : Molded plastic, SOD-123H
- Terminals :Plated terminals, solderable per MIL-STD-750, Method 2026
- Polarity : Indicated by cathode band
- Mounting Position : Any
- Weight : Approximated 0.011 gram

Package outline

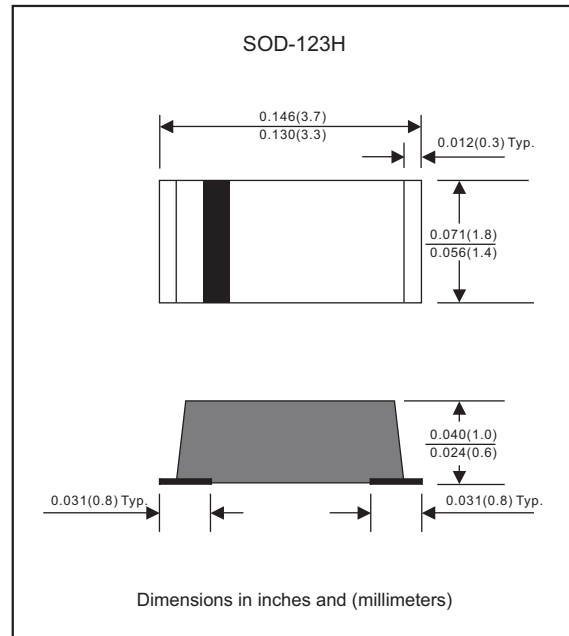

Maximum ratings (AT T_A=25°C unless otherwise noted)

PARAMETER	SYMBOLS	FM220-MH	FM230-MH	FM240-MH	FM250-MH	FM260-MH	FM280-MH	FM2100-MH	FM2150-MH	FM2200-MH	UNIT	
Maximum repetitive peak reverse voltage	V _{RRM}	20	30	40	50	60	80	100	150	200	V	
Maximum RMS voltage	V _{RMS}	14	21	28	35	42	56	70	105	140	V	
Maximum continuous reverse voltage	V _R	20	30	40	50	60	80	100	150	200	V	
Maximum average forward rectified current	I _O	2.0									A	
Non-repetitive peak forward surge current 8.3ms single half sine-wave	I _{FSM}	50									A	
Typical junction capacitance (Note 1)	C _J	110									pF	
Operating junction temperature range	T _J	-55 to +125				-55 to +150						°C
Storage temperature range	T _{STG}	-65 to +175										°C

Electrical characteristics (AT T_A=25°C unless otherwise noted)

PARAMETER	SYMBOLS	FM220-MH	FM230-MH	FM240-MH	FM250-MH	FM260-MH	FM280-MH	FM2100-MH	FM2150-MH	FM2200-MH	UNIT	
Maximum instantaneous forward voltage at I _F =2.0A	V _F	0.50			0.70		0.85		0.90		V	
Maximum reverse leakage current at rated V _R	I _R					0.5						mA
						10						mA

Thermal characteristics

PARAMETER	SYMBOLS	FM220-MH	FM230-MH	FM240-MH	FM250-MH	FM260-MH	FM280-MH	FM2100-MH	FM2150-MH	FM2200-MH	UNIT		
Typical thermal resistance junction to ambient (Note2)	R _{θJA}						76						°C/W
Typical thermal resistance junction to case (Note 2)	R _{θJC}						38						°C/W

Notes1: Measured at 1MHz and applied reverse voltage of 4.0V D.C

2: Mounted on FR-4 PCB copper, minimum recommended pad layout

Rating and characteristic curves (FM220-MH THRU FM2200-MH)

FIG.1-TYPICAL FORWARD CURRENT DERATING CURVE

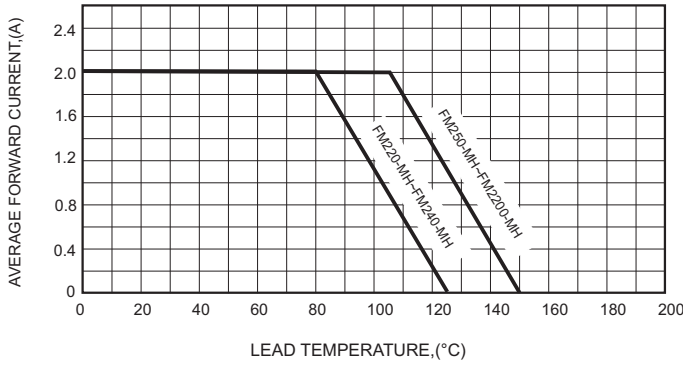

FIG.2-TYPICAL FORWARD CHARACTERISTICS

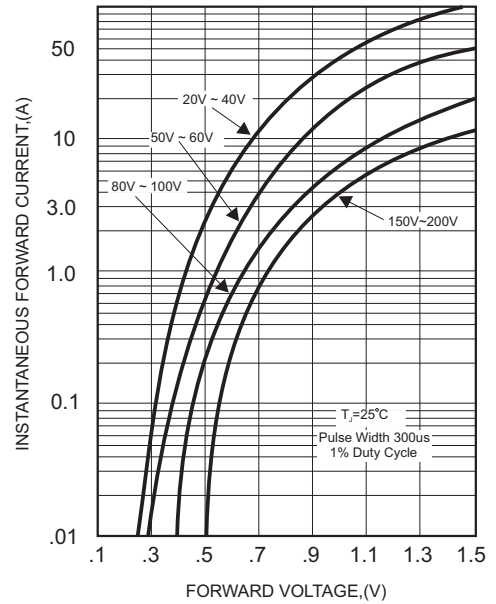

FIG.3-MAXIMUM NON-REPETITIVE FORWARD SURGE CURRENT

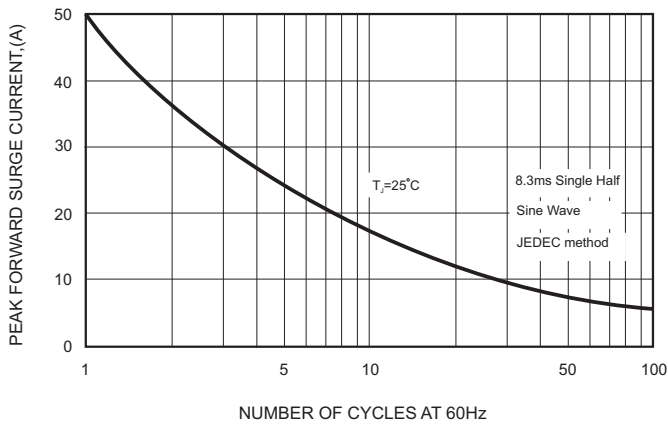

FIG.5 - TYPICAL REVERSE CHARACTERISTICS

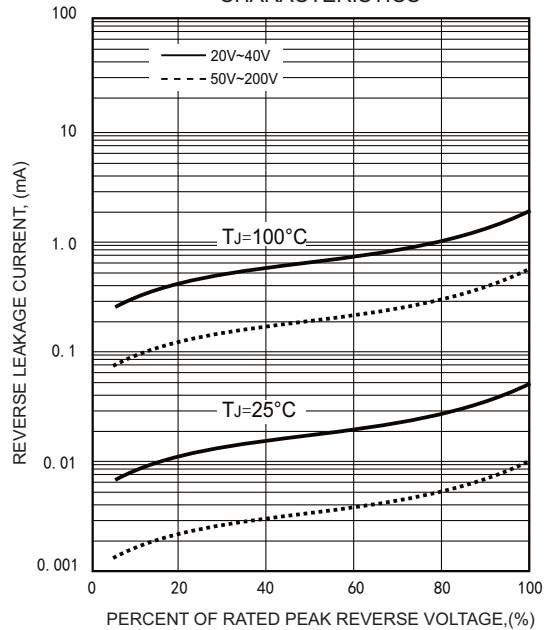
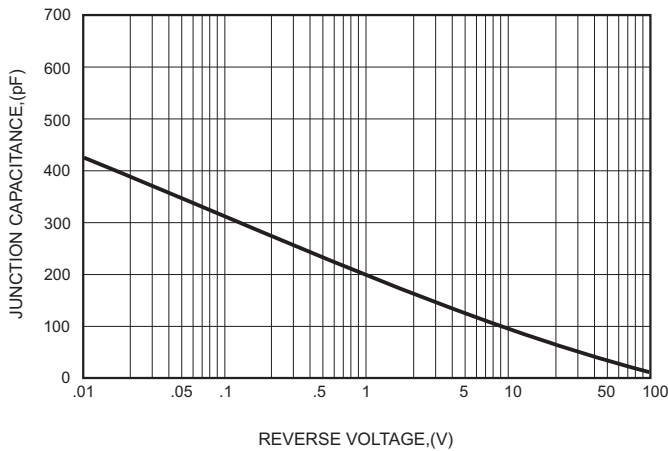



FIG.4-TYPICAL JUNCTION CAPACITANCE



FM220-MH THRU FM2200-MH

Pinning information

Pin	Simplified outline	Symbol
Pin1 cathode Pin2 anode		

Marking

Type number	Marking code
FM220-MH	22
FM230-MH	23
FM240-MH	24
FM250-MH	25
FM260-MH	26
FM280-MH	28
FM2100-MH	20
FM2150-MH	215
FM2200-MH	220

Suggested solder pad layout

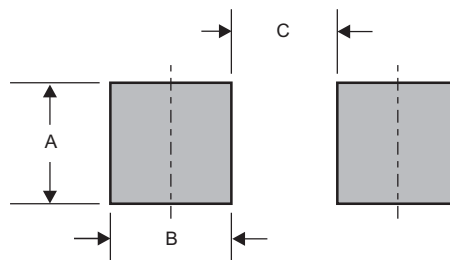

Dimensions in inches and (millimeters)

PACKAGE	A	B	C
SOD-123H	0.071 (1.80)	0.051 (1.30)	0.067 (1.70)

FM220-MH THRU FM2200-MH

Packing information

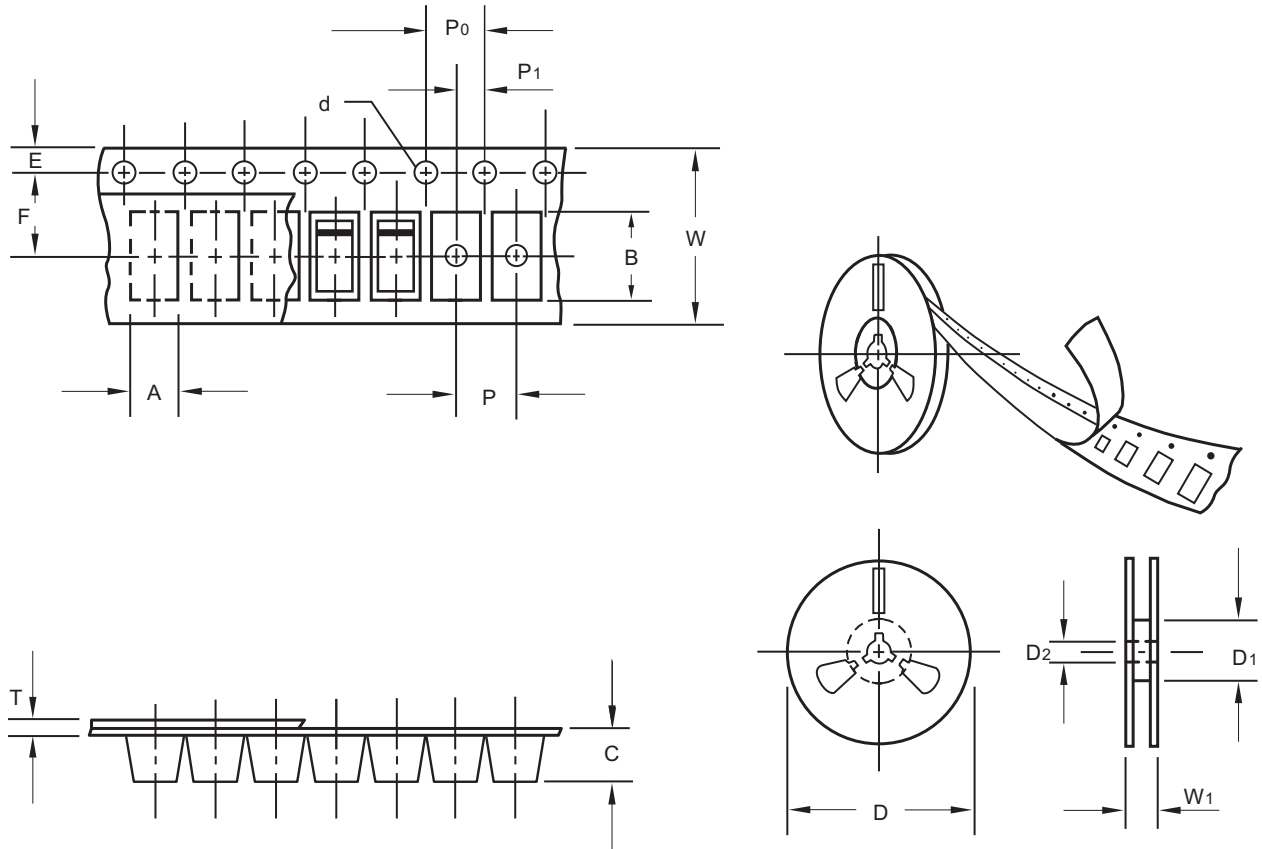

unit:mm

Item	Symbol	Tolerance	SOD-123H
Carrier width	A	0.1	2.00
Carrier length	B	0.1	3.85
Carrier depth	C	0.1	1.10
Sprocket hole	d	0.1	1.50
13" Reel outside diameter	D	2.0	-
13" Reel inner diameter	D1	min	-
7" Reel outside diameter	D	2.0	178.00
7" Reel inner diameter	D1	min	62.00
Feed hole diameter	D2	0.5	13.00
Sprocket hole position	E	0.1	1.75
Punch hole position	F	0.1	3.50
Punch hole pitch	P	0.1	4.00
Sprocket hole pitch	P0	0.1	4.00
Embossment center	P1	0.1	2.00
Overall tape thickness	T	0.1	0.23
Tape width	W	0.3	8.00
Reel width	W1	1.0	11.40

Note: Devices are packed in accordance with EIA standard RS-481-A and specifications listed above.

FM220-MH THRU FM2200-MH

Reel packing

PACKAGE	REEL SIZE	REEL (pcs)	COMPONENT SPACING (m/m)	BOX (pcs)	INNER BOX (m/m)	REEL DIA, (m/m)	CARTON SIZE (m/m)	CARTON (pcs)	APPROX. GROSS WEIGHT (kg)
SOD-123H	7"	3,000	4.0	30,000	183*123*183	178	382*257*387	240,000	9.0

Suggested thermal profiles for soldering processes

- 1.Storage environment: Temperature=5°C~40°C Humidity=55%±25%
- 2.Reflow soldering of surface-mount devices

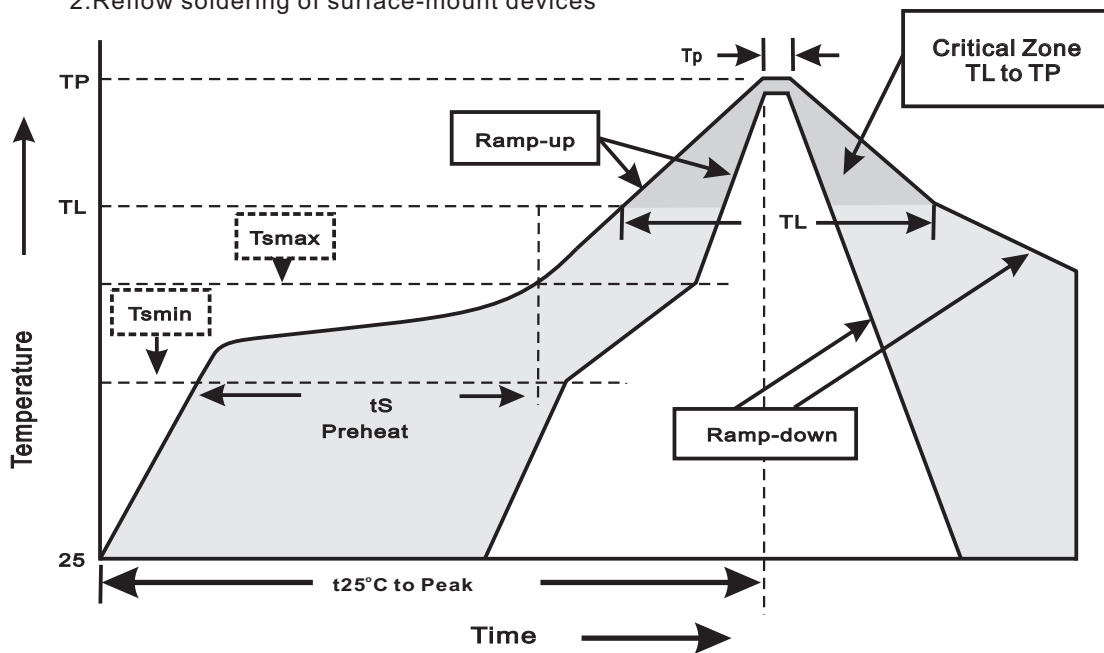

3.Reflow soldering

Profile Feature	Soldering Condition
Average ramp-up rate(TL to TP)	<3°C/sec
Preheat -Temperature Min(Tsmin) -Temperature Max(Tsmax) -Time(min to max)(ts)	150°C 200°C 60~120sec
Tsmax to TL -Ramp-upRate	<3°C/sec
Time maintained above: -Temperature(TL) -Time(tL)	217°C 60~260sec
Peak Temperature(TP)	255°C-0/+5°C
Time within 5°C of actual Peak Temperature(tp)	10~30sec
Ramp-down Rate	<6°C/sec
Time 25°C to Peak Temperature	<6minutes

FM220-MH THRU FM2200-MH**High reliability test capabilities**

Item Test	Conditions	Reference
1. Solder Resistance	at 260±5°C for 10±2sec.	MIL-STD-750D METHOD-2031
2. Solderability	at 245±5°C for 5 sec.	MIL-STD-202F METHOD-208
3. High Temperature Reverse Bias	$V_R=80\%$ rate at $T_J=125^\circ\text{C}$ for 168 hrs.	MIL-STD-750D METHOD-1038
4. Forward Operation Life	Rated average rectifier current at $T_A=25^\circ\text{C}$ for 500hrs.	MIL-STD-750D METHOD-1027
5. Intermittent Operation Life	$T_A = 25^\circ\text{C}$, $I_F = I_O$ On state: power on for 5 min. off state: power off for 5 min. on and off for 500 cycles.	MIL-STD-750D METHOD-1036
6. Pressure Cooker	15P _{SIG} at $T_A=121^\circ\text{C}$ for 4 hrs.	JESD22-A102
7. Temperature Cycling	-55°C to +125°C dwelled for 30 min. and transferred for 5min. total 10 cycles.	MIL-STD-750D METHOD-1051
8. Forward Surge	8.3ms single half sine-wave , one surge.	MIL-STD-750D METHOD-4066-2
9. Humidity	at $T_A=85^\circ\text{C}$, RH=85% for 1000hrs.	MIL-STD-750D METHOD-1021
10. High Temperature Storage Life	at 175°C for 1000 hrs.	MIL-STD-750D METHOD-1031