

Single Channel Smart Load Switch

Features

- 0.8V to $V_{BIAS}-1.5V$ input voltage range.
- Continuous Switch Current 6A
- Low $R_{DS(ON)}$ on internal NFETs
5.5m Ω at $V_{BIAS}=5V$, $V_{IN}=1.05V$, $T_A=25^\circ C$
- 35 μA low quiescent current
- 10 μs turn on rise time
- 3.2V to 5.5V bias voltage
- Integrated quick output discharge resistor
- Thermally enhanced TDFN3X3-8 package

Applications

- Portable computers
- Ultrabooks
- Tablet PCs
- Set top boxes
- LCD TVs
- Telecom/Networking/Datacom equipment
- Consumer electronics
- SSD

General Description

The G5027C is a signal channel smart load switch with very low on-resistance in a small package. It contains an n-channel MOSFET for up to $V_{BIAS}-1.5V$ input voltage operation and 10A current channel with 3.2V to 5.5V bias supply. The load switch is controlled by a low voltage control signal through ON pin.

The G5027C integrates an internal 220 Ω load resistor for quick output discharge when load switch is off.

The G5027C is available is a TDFN3X3-8 package with bottom thermal pad and is rated over a $-40^\circ C$ to $85^\circ C$ ambient temperature range.

Ordering Information

ORDER NUMBER	MARKING	TEMP. RANGE	PACKAGE (Green)
G5027CRD1D	5027	$-40^\circ C$ to $85^\circ C$	TDFN3X3-8

Note: RD: TDFN3X3-8

1: Bonding Code

D: Tape & Reel

Green : Lead Free / Halogen Free

Pin configuration

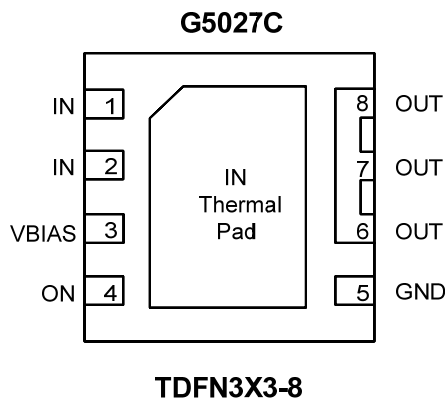

Typical Application Circuit

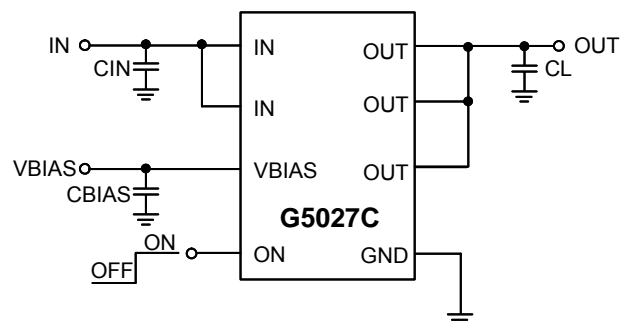

Absolute Maximum Ratings

IN,ON,VBIAS,OUT to GND -0.3V to +6V
 Junction Temperature(T_J) 150°C
 Storage Temperature(T_s) -65°C to 150°C
 ESD Rating HBM/CDM 2kV/1KV

Recommend Operating Ratings

Supply Voltage (V_{IN}) V_{BIAS}-1.5V
 Ambient Temperature(T_A) -40°C to 85°C
 Thermal Resistance of junction to ambient (θ_{JA})
 TDFN3X3-8 170°C/W
 Thermal Resistance of junction to case (θ_{JC})
 TDFN3X3-8 30°C/W

Electrical Characteristics

(V_{BIAS} = 5V, V_{IN} = 1.05V, T_A = 25°C, unless otherwise specifications in BOLD indicate a temperature range of -40°C to +85°C)

PARAMETER	SYMBOL	Conditions	MIN	TYP	MAX	UNITS
Input Voltage Range	V _{IN}	V _{ON} =5V	0.8	1.05	V _{BIAS} -1.5	V
VBIAS supply Voltage	V _{BIAS}		3.2	5	5.5	V
Maximum Continuous Current	I _D	V _{ON} =5V	---	6	---	A
Maximum Pulsed Switch Current	I _{PLS}	V _{IN} = V _{ON} =5V Pulse <300μs, 2% Duty cycle	---	8	---	A
Quiescent Supply Current of VBIAS	I _q	V _{ON} =5V, I _{OUT} =0A	---	50	---	μA
VBIAS Shutdown Supply Current	I _{OFF}	V _{ON} =0V, V _{OUT} =0V	---	---	2	μA
IN Shutdown Supply Current	I _{INOFF}	V _{ON} =0V, V _{OUT} =0V	---	---	2	μA
ON Leakage Current	I _{ON}	V _{ON} =5V	---	---	1	μA
ON High level Voltage	V _{ONH}		1.2	---	---	V
ON Low level Voltage	V _{ONL}		---	---	0.5	V
Switching ON Resistance						
Switch ON-State Resistance	R _{ON}	I _{OUT} =-200mA, V _{ON} =5V, V _{BIAS} =5V	---	5.5	---	mΩ
		I _{OUT} =-200mA, V _{ON} =5V, V _{BIAS} =3.3V	---	6.5	---	mΩ
Output Pull-Down Resistance	R _{PD}	I _{OUT} =-15mA, V _{ON} =0V,	---	220	300	Ω

Switching Characteristics

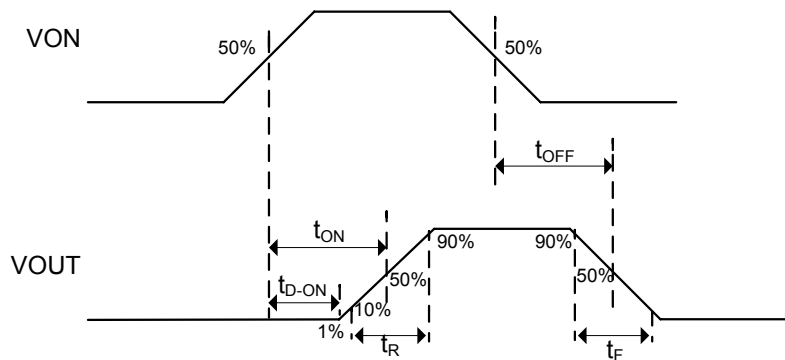

Typical Performance Characteristics

$V_{IN}=1.05V$, $V_{BIAS}=V_{ON}=5V$, $T_A=25^\circ C$, unless otherwise noted.

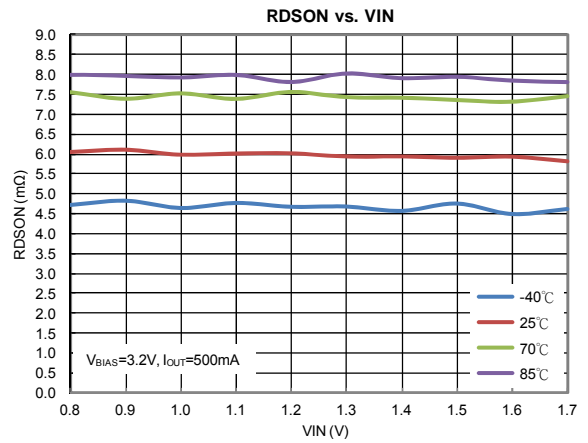
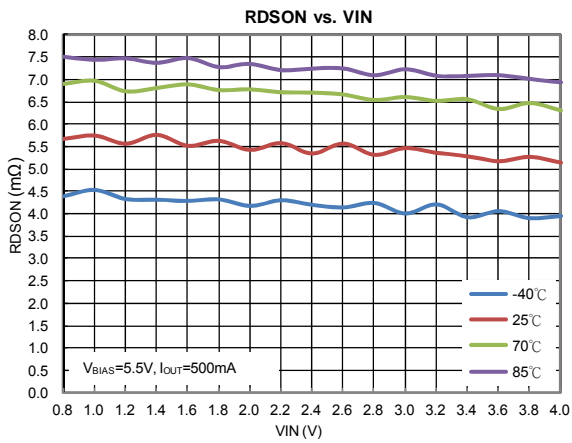
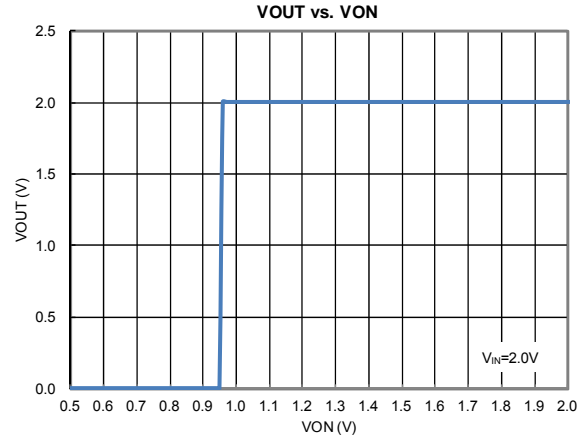
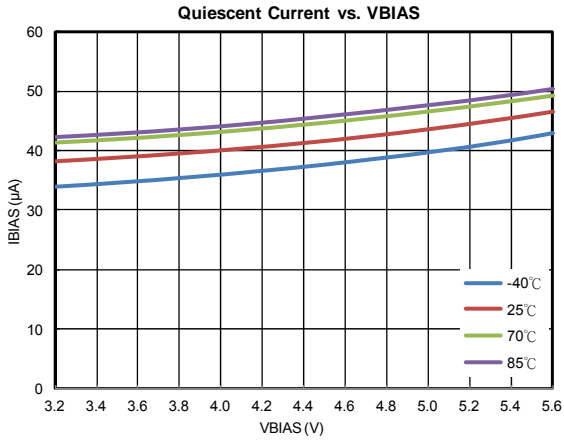

Typical Performance Characteristics (continued)

Turn-ON & Turn-ON Rise Times

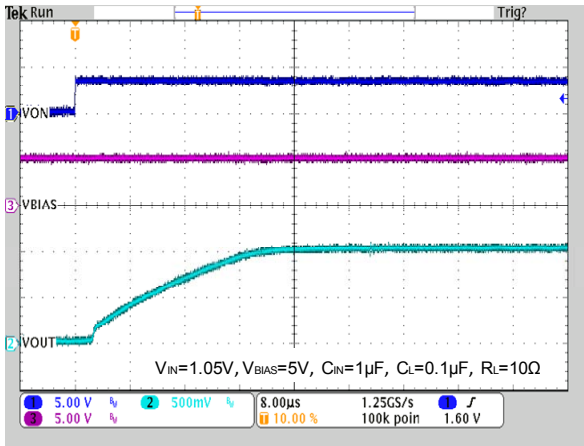

Turn-OFF & Turn-OFF Fall Times

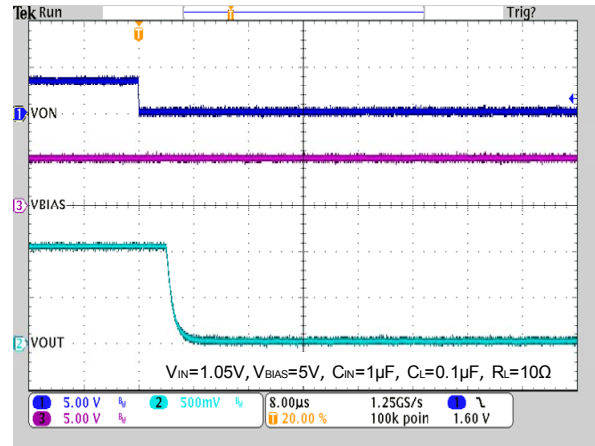

Turn-ON & Turn-OFF at $I_{OUT}=6A$

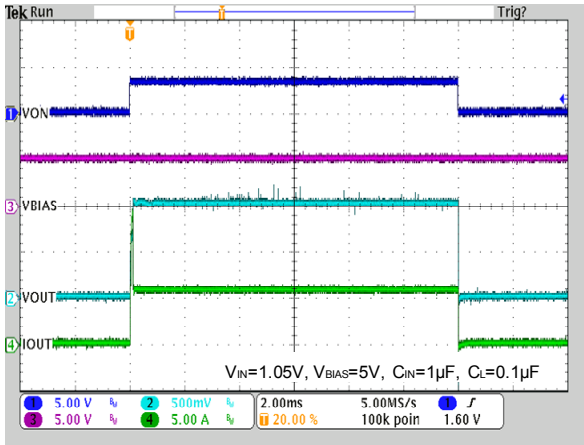

Test condition $T_A=25^{\circ}\text{C}$, $C_{IN}=1\mu\text{F}$, $C_L=0.1\mu\text{F}$, $R_L=10\Omega$, (unless otherwise specified)

SYMBOL	PARAMETER	MIN	TYP	MAX	UNITS
VIN=1.5V, VBIAS=VON=5V					
T_{ON}	Turn-ON Time	---	10	---	μS
T_{D-ON}	Turn-ON Delay Time	0.5	2.5	9	
T_R	Turn-ON Rise Time	11	23	40	
T_{OFF}	Turn-OFF Time	---	5	---	
T_F	Turn-OFF Fall Time	---	2	---	

Test condition $T_A=25^{\circ}\text{C}$, $C_{IN}=1\mu\text{F}$, $C_L=0.1\mu\text{F}$, $R_L=10\Omega$, (unless otherwise specified)

SYMBOL	PARAMETER	MIN	TYP	MAX	UNITS
VIN=1.05V, VBIAS=VON=5V					
T_{ON}	Turn-ON Time	---	10	---	μS
T_{D-ON}	Turn-ON Delay Time	0.5	2.5	9	
T_R	Turn-ON Rise Time	10	21	37	
T_{OFF}	Turn-OFF Time	---	5	---	
T_F	Turn-OFF Fall Time	---	2	---	

Test condition $T_A=25^{\circ}\text{C}$, $C_{IN}=1\mu\text{F}$, $C_L=0.1\mu\text{F}$, $R_L=10\Omega$, (unless otherwise specified)

SYMBOL	PARAMETER	MIN	TYP	MAX	UNITS
VIN=1.05V, VBIAS=VON=3.3V					
T_{ON}	Turn-ON Time	---	26	---	μS
T_{D-ON}	Turn-ON Delay Time	---	6	---	
T_R	Turn-ON Rise Time	---	43	---	
T_{OFF}	Turn-OFF Time	---	5	---	
T_F	Turn-OFF Fall Time	---	2.5	---	

Application Circuit for Powering rails to sensitive to Ringing

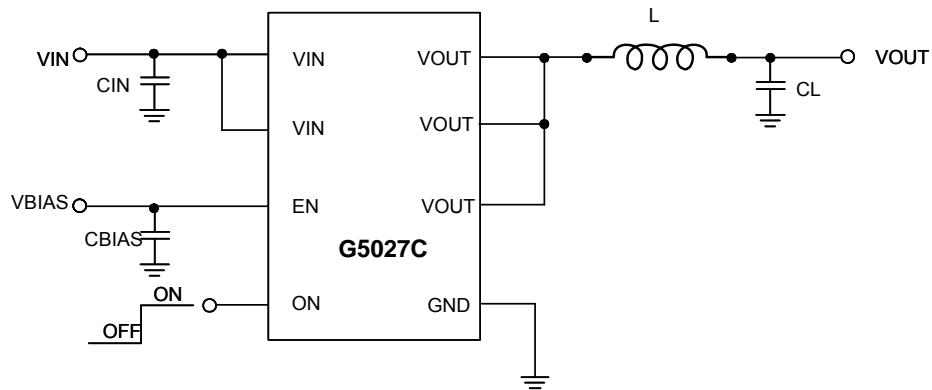

Minimum Footprint PCB Layout Section

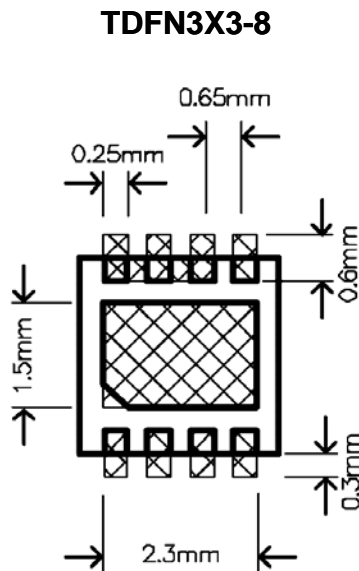

Pin Description

PIN	NAME	FUNCTION
1, 2, thermal pad	IN	Load Switch Input. Bypass capacitor is recommended to minimize input voltage dip. Recommended voltage range of this pin is 0.8V to $V_{BIAS}-1.5V$ to obtain optional R_{ON} .
3	VBIAS	Bias voltage. Power supply input for the device. Recommended voltage range is 3.2V to 5.5V.
4	ON	Enable Input. Load switch is on when ON is pulled high. Load switch is off when ON is pulled low. Do not leave floating.
5	GND	Ground.
6,7,8	OUT	Load switch output

Block Diagram

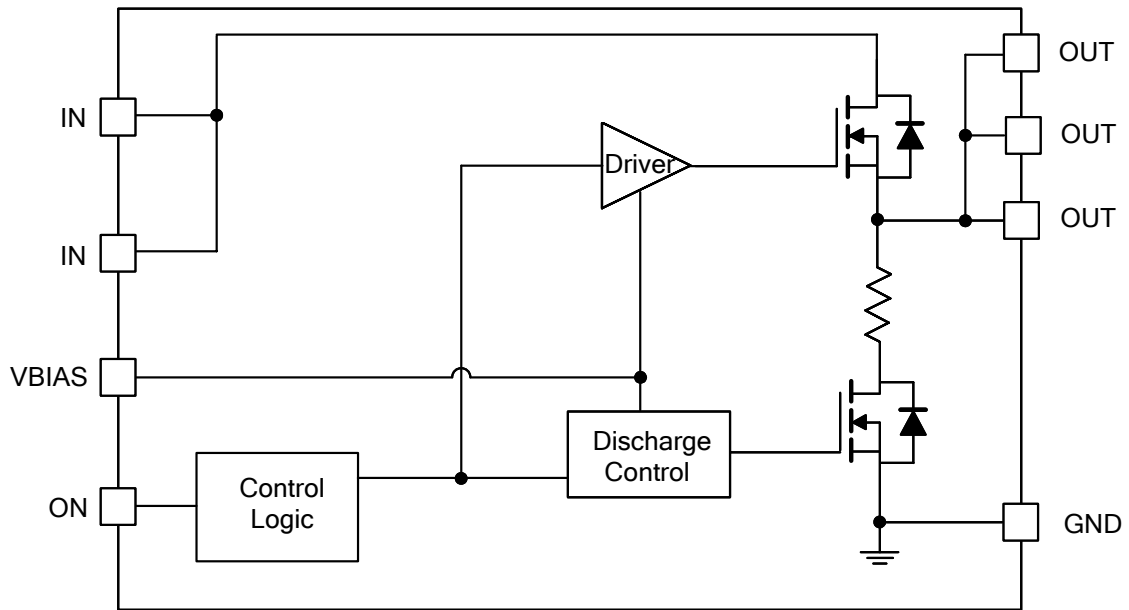

Detailed Description

ON/OFF control

The G5027C is enabled when the ON pin is on active high with 1.2V or above voltage. The device is disabled when the ON pin voltage is 0.5V or lower. The ON input is compatible with both TTL and CMOS logic.

VBIAS Voltage Range

For optimal on-resistance of load switch, make sure $V_{IN} \leq 1.5V + V_{BIAS}$ and V_{BIAS} is within the voltage range from 3.2V to 5.5V. On-resistance of load switch will be higher if $V_{IN} + 1.5V > V_{BIAS}$. Resistance curves of a typical sample device at different $V_{BIAS} = V_{IN}$ at $I_{OUT} = -200mA$ are shown as below.

Application Information

The basic G5027C application circuit is shown in the first page. Component selection is explained below.

Input Capacitor

A capacitor of 10 μ F or higher value is recommended to be placed close to the IN pins of G5027C. This capacitor can reduce the voltage drop caused by the in-rush current during the turn-on transient of the load switch. A higher value capacitor can be used to further reduce the voltage drop during high-current application.

Output Capacitor

A capacitor of 10 or higher value is recommended to be placed between the OUT pins and GND. The switching times are affected by the capacitance. A large capacitor makes the initial turn-on transient smoother. This capacitor must be large enough to supply a fast transient load in order to prevent the output from dropping.

Thermal Considerations

To ensure proper operation, the maximum junction temperature of the G5027C should not exceed 150°C. Several factors attribute to the junction temperature rise: load current, MOSFET on-resistance, junction-to-ambient thermal resistance, and ambient temperature. The maximum load current can be determined by:

It is noted that the maximum continuous load current is 10A.

Layout Guidelines

Good PCB is important for improving the thermal performance of G5027C. Place the input and output bypass capacitors close to the IN and OUT pins. The input and output PCB traces should be as wide as possible for the given PCB space. Use a ground plane to enhance the power dissipation capability of the device.

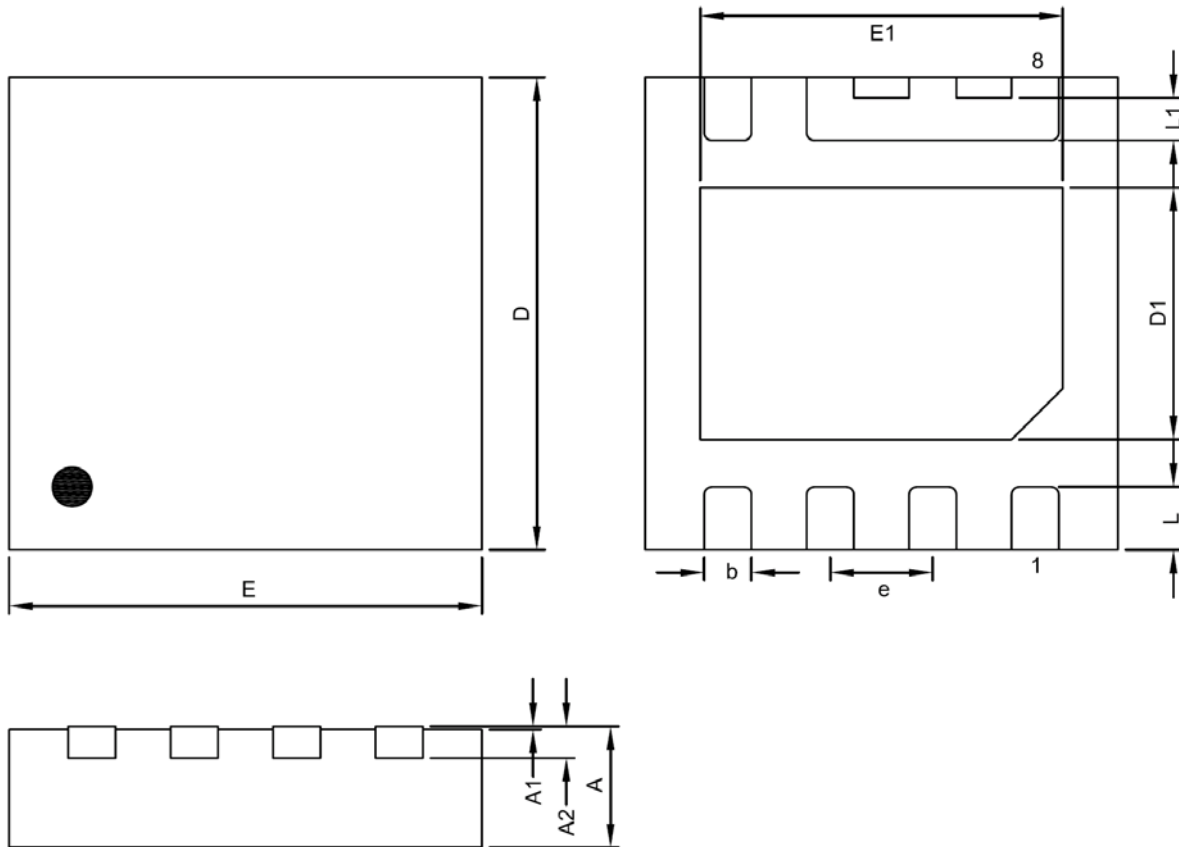
Package Information

TDFN3X3-8 Package

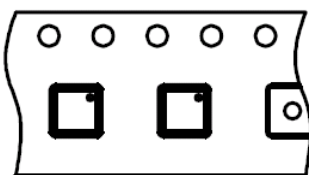
Symbol	DIMENSION IN MM			DIMENSION IN INCH		
	MIN.	NOM.	MAX.	MIN.	NOM.	MAX.
A	0.70	0.75	0.80	0.0276	0.0295	0.0315
A1	0.00	---	0.05	0.0000	---	0.0020
A2	0.20 REF			0.0079 REF		
D	2.95	3.00	3.05	0.1161	0.1181	0.1201
E	2.95	3.00	3.05	0.1161	0.1181	0.1201
D1	1.50	1.60	1.70	0.0591	0.0630	0.0670
E1	2.30	2.40	2.50	0.0906	0.0945	0.0984
b	0.25	0.30	0.35	0.0098	0.0118	0.0138
e	0.65 BSC			0.0256 BSC		
L	0.30	0.40	0.50	0.0118	0.0157	0.0197
L1	0.25 REF			0.0079 REF		

Taping Specification

Feed Direction

PACKAGE	Q'TY/REEL
TDFN3X3-8	3,000 ea

GMT Inc. does not assume any responsibility for use of any circuitry described, no circuit patent licenses are implied and GMT Inc. reserves the right at any time without notice to change said circuitry and specifications.