

FEATURES

- Low Frequency Power Amplifier

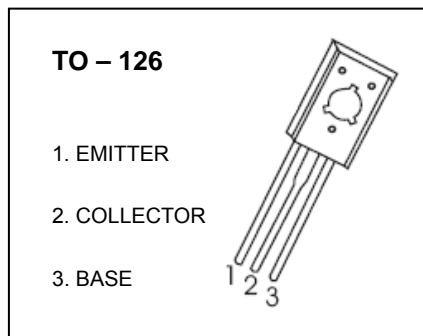

MARKING

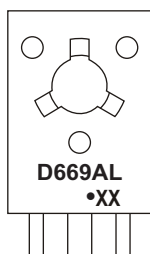

D669AL=Device code
Solid dot= Green molding compound device, if none, the normal device
XX=Code

Equivalent Circuit

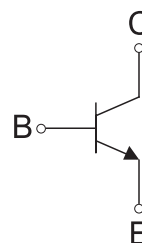

ORDERING INFORMATION

Part Number	Package	Packing Method	Pack Quantity
2SD669AL	TO-126	Bulk	200pcs/Bag
2SD669AL-TU	TO-126	Tube	60pcs/Tube

MAXIMUM RATINGS (T_a=25°C unless otherwise noted)

Symbol	Parameter	Value	Unit
V _{CB0}	Collector-Base Voltage	200	V
V _{CEO}	Collector-Emitter Voltage	170	V
V _{EBO}	Emitter-Base Voltage	6.5	V
I _C	Collector Current	1	A
P _C	Collector Power Dissipation	1	W
R _{θJA}	Thermal Resistance from Junction to Ambient	125	°C/W
T _J , T _{stg}	Operation Junction and Storage Temperature Range	-55~+150	°C

ELECTRICAL CHARACTERISTICS

$T_a=25\text{ }^\circ\text{C}$ unless otherwise specified

Parameter	Symbol	Test conditions	Min	Typ	Max	Unit
Collector-base breakdown voltage	$V_{(BR)CBO}$	$I_C=100\mu\text{A}, I_E=0$	200			V
Collector-emitter breakdown voltage	$V_{(BR)CEO}$	$I_C=1\text{mA}, I_B=0$	170			V
Emitter-base breakdown voltage	$V_{(BR)EBO}$	$I_E=100\mu\text{A}, I_C=0$	6.5			V
Collector cut-off current	I_{CBO}	$V_{CB}=195\text{V}, I_E=0$			1	μA
Collector cut-off current	I_{CEO}	$V_{CE}=165\text{V}, I_B=0$			2	μA
Emitter cut-off current	I_{EBO}	$V_{EB}=5\text{V}, I_C=0$			0.1	μA
DC current gain	$h_{FE(1)}$	$V_{CE}=5\text{V}, I_C=0.15\text{A}$	100		320	
	$h_{FE(2)}$	$V_{CE}=5\text{V}, I_C=500\text{mA}$	33			
Collector-emitter saturation voltage	$V_{CE(sat)}$	$I_C=0.5\text{A}, I_B=0.05\text{A}$			0.9	V
Base-emitter voltage	V_{BE}	$V_{CE}=5\text{V}, I_C=0.15\text{A}$			1.4	V
Collector output capacitance	C_{ob}	$V_{CB}=10\text{V}, I_E=0, f=1\text{MHz}$		14		pF
Transition frequency	f_T	$V_{CE}=5\text{V}, I_C=150\text{mA}$		140		MHz

CLASSIFICATION of $h_{FE(1)}$

RANK	C	D
RANGE	100-200	160-320

Typical Characteristics

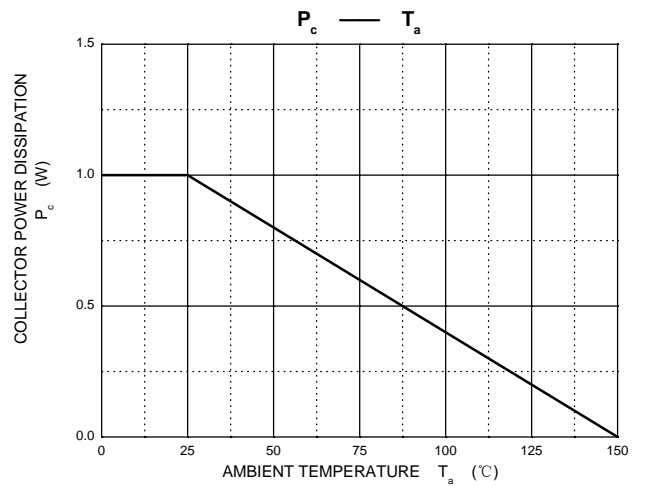
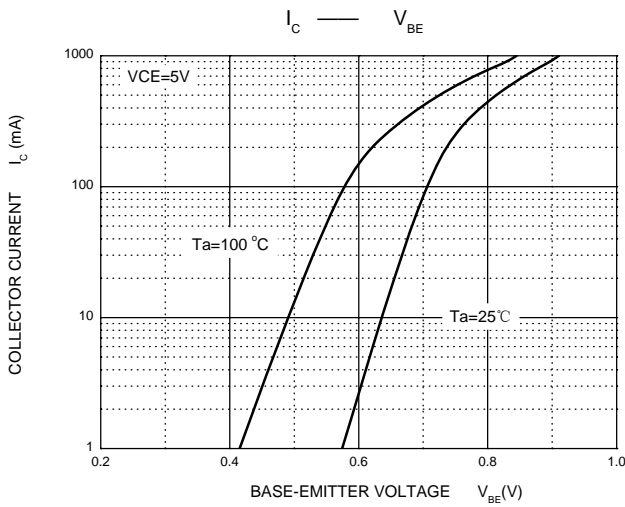
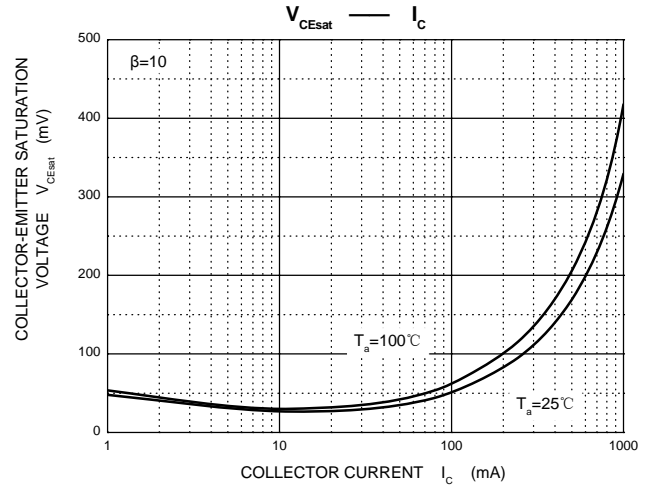
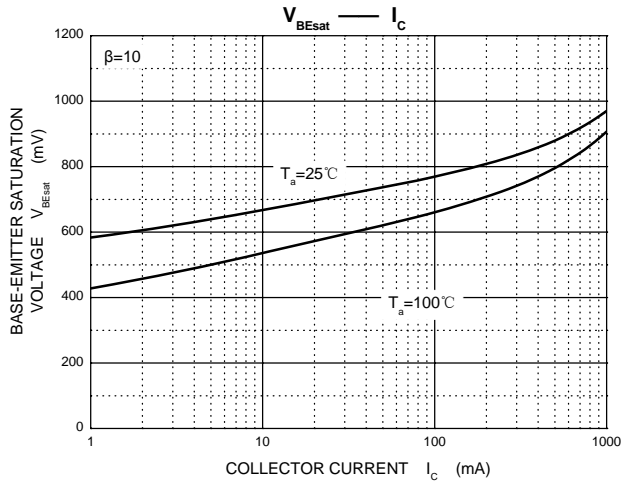
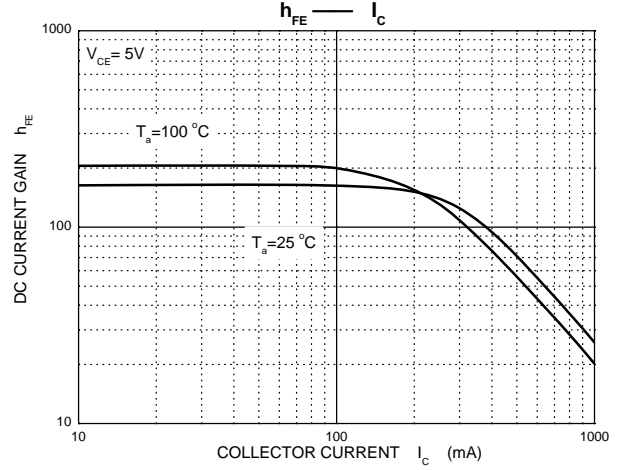
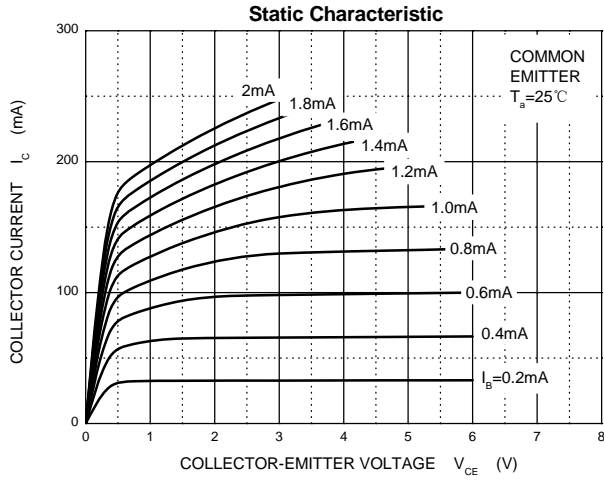

TO-126 Package Outline Dimensions

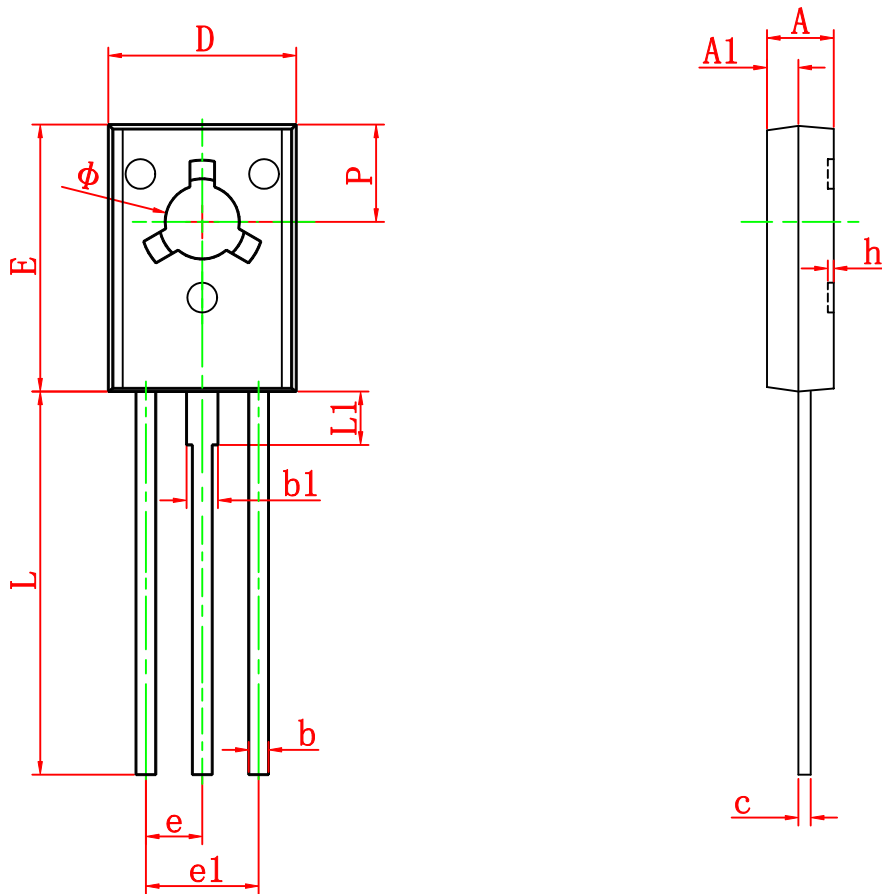

Symbol	Dimensions In Millimeters		Dimensions In Inches	
	Min	Max	Min	Max
A	2.500	2.900	0.098	0.114
A1	1.100	1.500	0.043	0.059
b	0.660	0.860	0.026	0.034
b1	1.170	1.370	0.046	0.054
c	0.450	0.600	0.018	0.024
D	7.400	7.800	0.291	0.307
E	10.600	11.000	0.417	0.433
e	2.290 TYP		0.090 TYP	
e1	4.480	4.680	0.176	0.184
h	0.000	0.300	0.000	0.012
L	15.300	15.700	0.602	0.618
L1	2.100	2.300	0.083	0.091
P	3.900	4.100	0.154	0.161
Φ	3.000	3.200	0.118	0.126