



500mA, LOW DROPOUT, LOW NOISE ULTRA-FAST WITH SOFT START CMOS LDO REGULATOR

DESCRIPTION

UTC LR1120 a 500mA LDO regulator, has very high PSRR and super low dropout voltage especially suitable for wireless and portable applications.

In the field of hand-held wireless devices, board space and battery life are the main concerns of designers and end-users. Because of the low quiescent current and low ESR ceramic capacitors, UTC LR1120 can satisfy those concerns.

Furthermore, low current consumption in shutdown mode (0.7µA), fast turn-on time (<70µs), high output accuracy, current limiting protection, and high ripple rejection ratio are advantages of UTC LR1120.

FEATURES

- * Operating Voltage Ranges : 2.2V to 5.5V
- * Dropout : 250mV at 500mA
- * When IC Shutdown: 5mA Discharge Current of V_{OUT}
- * Extreme Low Noise for DSC Application
- * Extreme Fast Response in Line/Load Transient
- * Internal Current Limiting Protection
- * Internal Thermal Shutdown Protection
- * High PSRR
- * Recommended 1µF Output Capacitor only for Stability
- * With TTL Logic Controlled Shutdown Input

ORDERING INFORMATION

Ordering Number		Package	Packing
Lead Free	Halogen Free		
LR1120L-xx-AF5-x-R	LR1120G-xx-AF5-x-R	SOT-25	Tape Reel
LR1120L-xx-AL5-x-R	LR1120G-xx-AL5-x-R	SOT-353	Tape Reel

Note: xx: Output Voltage, refer to Marking Information.

<p>LR1120G-xx-AF5-x-R</p> <p>(1) Packing Type (2) Pin Code (3) Package Type (4) Output Voltage Code (5) Green Package</p>	<p>(1) R: Tape Reel (2) Refer to Pin Assignment (3) AF5: SOT-25, AL5: SOT-353 (4) xx: Refer to Marking Information (5) G: Halogen Free and Lead Free, L: Lead Free</p>
---	--

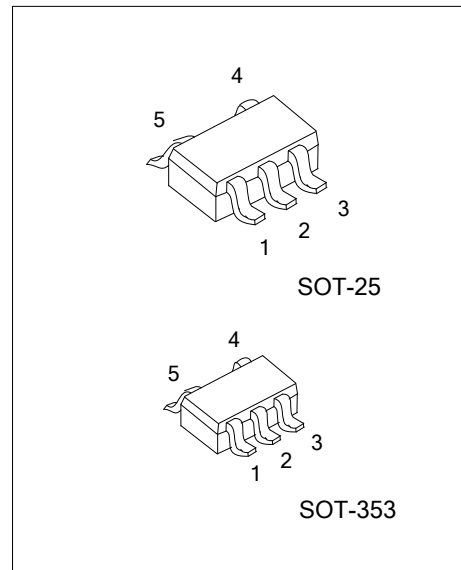

MARKING INFORMATION

PACKAGE	VOLTAGE CODE	MARKING
SOT-25 SOT-353	18 :1.8V 25 :2.5V 28 :2.8V 30 :3.0V 31 :3.1V 33 :3.3V 40 :4.0V	

PIN DESCRIPTION

PIN CODE				PIN NAME	DESCRIPTION
A	B	C	D		
1	1	1	2	V_{IN}	Supply voltage input.
2	2	2	1	GND	Ground.
3	3	3	-	EN	Input logic pin, active high for enabling the chip. When this pin goes to a logic low, the chip will be shutdown.
4	-	-	-	SS	Soft start pin.
5	4	5	3	V_{OUT}	Regulator output voltage pin.
-	5	4	4, 5	NC	No Connection

BLOCK DIAGRAM

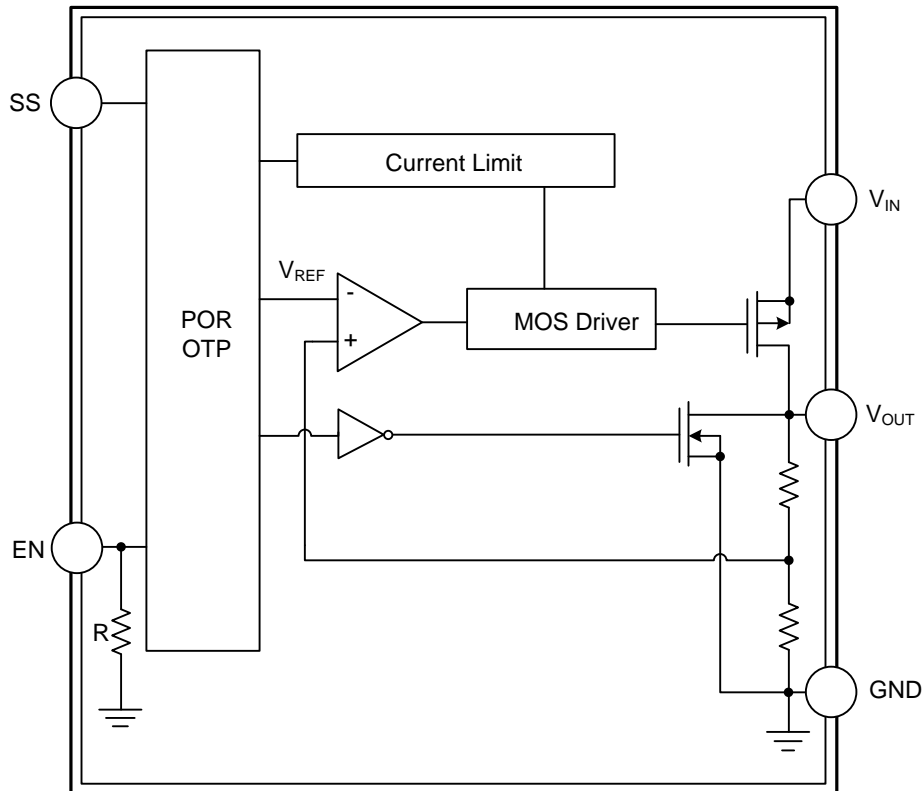

■ ABSOLUTE MAXIMUM RATING (T_A = 25°C, unless otherwise specified.)

PARAMETER	SYMBOL	RATINGS	UNIT
Supply Input Voltage	V _{IN}	6	V
EN Input Voltage	V _{EN}	6	V
Power Dissipation (T _A = 25°C)	SOT-25	0.38	W
	SOT-353	0.25	W
Junction Temperature	T _J	+150	°C
Storage Temperature	T _{STG}	-65~ +150	°C

Note: Absolute maximum ratings are those values beyond which the device could be permanently damaged. Absolute maximum ratings are stress ratings only and functional device operation is not implied.

■ THERMAL DATA

PARAMETER	SYMBOL	RATINGS	UNIT
Junction to Ambient	SOT-25	260	°C/W
	SOT-353	400	°C/W

■ OPERATING CONDITIONS

PARAMETER	SYMBOL	RATINGS	UNIT
Supply Input Voltage	V _{IN}	2.2 ~ 5.5	V
Junction Temperature	T _J	-40 ~ +125	°C
Ambient Temperature	T _A	-40 ~ +85	°C

Note: The device is not guaranteed to function outside its operating conditions.

■ ELECTRICAL CHARACTERISTICS

(V_{IN} = V_{OUT} + 0.5V, V_{EN} = V_{IN}, C_{IN} = C_{OUT} = 1μF (Ceramic), T_A = 25°C, unless otherwise specified.)

PARAMETER	SYMBOL	TEST CONDITIONS	MIN	TYP	MAX	UNIT
Input Voltage	V _{IN}		2.2		5.5	V
Output Voltage Accuracy	ΔV _{OUT}	I _{OUT} = 10mA	-2	0	+2	%
Line Regulation	$\frac{\Delta V_{OUT}}{\Delta V_{IN} \times V_{OUT}}$	V _{IN} = (V _{OUT} +0.5V) ~ 5.5V, I _{OUT} = 1mA		0.01	0.2	%/V
Load Regulation (Note 1)	$\frac{\Delta V_{OUT}}{V_{OUT}}$	1mA < I _{OUT} < 400mA, 2.2V ≤ V _{IN} < 2.7V			0.6	%
		1mA < I _{OUT} < 500mA, 2.7V ≤ V _{IN} ≤ 5.5V			1	%
Quiescent Current (Note 2)	I _Q	V _{EN} = 5V, I _{OUT} = 0mA		25	70	μA
Standby Current	I _{STN-BY}	V _{EN} = 0V		0.7	1.5	μA
Current Limit	I _{LIMIT}	R _{LOAD} = 0Ω, 2.2V ≤ V _{IN} < 2.7V	0.4	0.7	1.05	A
		R _{LOAD} = 0Ω, 2.7V ≤ V _{IN} ≤ 5.5V	0.5	0.8	1.05	A
Dropout Voltage (Note 3)	V _D	I _{OUT} = 400mA		160	320	mV
		I _{OUT} = 500mA		250	400	
Soft Start Time		V _{OUT} = 2.5V, C _{SS} = 1nF, C _{OUT} = 1μF		0.7	1	ms
EN Threshold	Logic-Low	V _{IL}	0		0.6	V
	Logic-High	V _{IH}	1.6		5.5	V
Enable Pin Current	I _{EN}		0.1	1	5	μA
Over Temperature Shutdown	OTS			170		°C
Over Temperature Hysteresis	OTH			30		°C
Power Supply Rejection Rate	PSRR	I _{OUT} = 10mA, f = 10kHz		55		dB
Output Noise Voltage	e _N	V _{OUT} = 1.5V, C _{OUT} = 1μF, I _{OUT} = 0mA, C _{SS} = 1nF		40		μV _{RMS}

Notes: 1. Regulation is measured at constant junction temperature by using a 2ms current pulse. Devices are tested for load regulation in the load range from 1mA to 500mA.

2. Quiescent, or ground current, is the difference between input and output currents. It is defined by I_Q = I_{IN} - I_{OUT} under no load condition (I_{OUT} = 0mA). The total current drawn from the supply is the sum of the load current plus the ground pin current.

3. The dropout voltage is defined as V_{IN} - V_{OUT}, which is measured when V_{OUT} is V_{OUT(NORMAL)} × 98%.

■ TYPICAL APPLICATION CIRCUIT

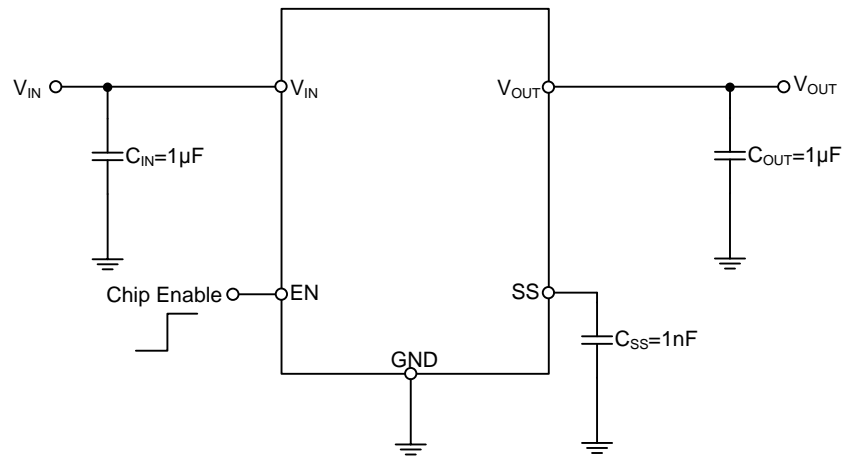

UTC assumes no responsibility for equipment failures that result from using products at values that exceed, even momentarily, rated values (such as maximum ratings, operating condition ranges, or other parameters) listed in products specifications of any and all UTC products described or contained herein. UTC products are not designed for use in life support appliances, devices or systems where malfunction of these products can be reasonably expected to result in personal injury. Reproduction in whole or in part is prohibited without the prior written consent of the copyright owner. UTC reserves the right to make changes to information published in this document, including without limitation specifications and product descriptions, at any time and without notice. This document supersedes and replaces all information supplied prior to the publication hereof.