

NPN SILICON RF POWER TRANSISTOR

DESCRIPTION:

The **ASI AM81214-030** is Designed for 1215 – 1400 MHz, L-Band Radar Applications.

FEATURES:

- Internal Input/Output Matching Network
- $P_G = 7.2$ dB at 5.0 W(peak)/1400 MHz
- **Omnigold™** Metalization System

MAXIMUM RATINGS

I_C	2.75 A
V_{CC}	32 V
P_{DISS}	63 W @ $T_C = 25$ °C
T_J	-65 °C to +250 °C
T_{STG}	-65 °C to +200 °C
θ_{JC}	2.4 °C/W

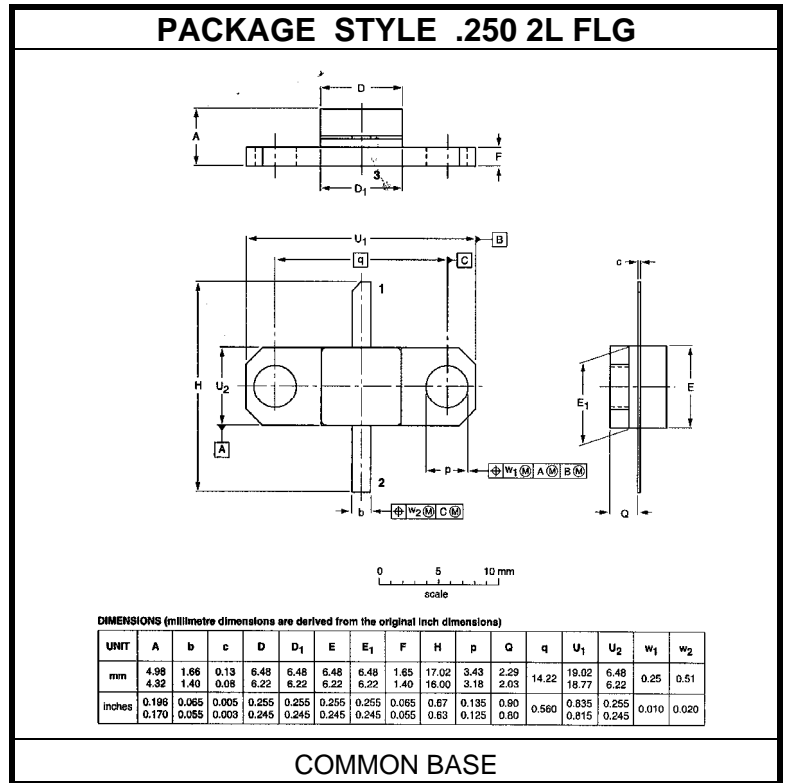
CHARACTERISTICS $T_C = 25$ °C

SYMBOL	TEST CONDITIONS	MINIMUM	TYPICAL	MAXIMUM	UNITS
BV_{CBO}	$I_C = 10$ mA	55			V
BV_{CER}	$I_C = 20$ mA $R_{BE} = 10$ Ω	55			V
BV_{EBO}	$I_E = 1.0$ mA	3.5			V
I_{CES}	$V_{CE} = 28$ V			5.0	mA
h_{FE}	$V_{CE} = 5.0$ V $I_C = 1.0$ A	15		150	---
P_{IN}		26	36		W
P_G	$V_{CC} = 28$ V $P_{IN} = 5.0$ W $f = 1215$ to 1400 MHz	7.2	8.5		dB
η_C		45	49		%