

# SFM21-S THRU SFM28-S

## List

List.....	1
Package outline.....	2
Features.....	2
Mechanical data.....	2
Maximum ratings and Electrical characteristics .....	2
Rating and characteristic curves.....	3
Pinning information.....	4
Marking.....	4
Suggested solder pad layout.....	4
Packing information.....	5
Reel packing.....	6
Suggested thermal profiles for soldering processes.....	6
High reliability test capabilities.....	7

# SFM21-S THRU SFM28-S

## 2.0A Surface Mount Super Fast Rectifiers 50V-600V

### Features

- Batch process design, excellent power dissipation offers better reverse leakage current and thermal resistance
- Low profile surface mounted application in order to optimize board space
- High current capability
- Superfast recovery tim for switching mode application
- High surge current capability
- Glass passivated chip junction
- Lead-free parts meet RoHS requirements
- Suffix "-H" indicates Halogen free parts, ex. SFM21-S-H

### Mechanical data

- Epoxy:UL94-V0 rated flame retardant
- Case : Molded plastic, SMA-S
- Terminals : Solder plated, solderable per MIL-STD-750, Method 2026
- Polarity : Indicated by cathode band
- Mounting Position : Any
- Weight : Approximated 0.05 gram

### Package outline

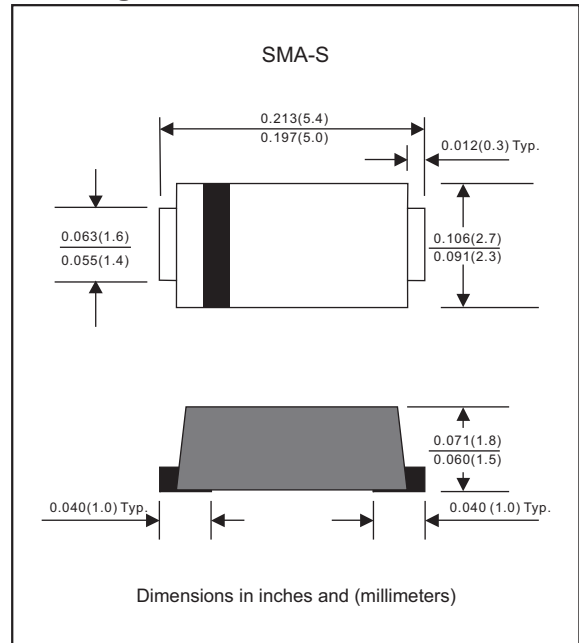

### Maximum ratings (AT $T_A=25^{\circ}\text{C}$ unless otherwise noted)

PARAMETER	SYMBOLS	SFM21-S	SFM22-S	SFM23-S	SFM24-S	SFM25-S	SFM26-S	SFM27-S	SFM28-S	UNIT
Maximum repetitive peak reverse voltage	$V_{RRM}$	50	100	150	200	300	400	500	600	V
Maximum RMS voltage	$V_{RMS}$	35	70	105	140	210	280	350	420	V
Maximum continuous reverse voltage	$V_R$	50	100	150	200	300	400	500	600	V
Maximum average forward rectified current	$I_o$	2.0								A
Non-repetitive peak forward surge current 8.3ms single half sine-wave	$I_{FSM}$	50								A
Typical junction capacitance (Note 1)	$C_J$	25								pF
Operating junction temperature range	$T_J$	-55 to +150								$^{\circ}\text{C}$
Storage temperature range	$T_{STG}$	-65 to +175								$^{\circ}\text{C}$

### Electrical characteristics (AT $T_A=25^{\circ}\text{C}$ unless otherwise noted)

PARAMETER	SYMBOLS	SFM21-S	SFM22-S	SFM23-S	SFM24-S	SFM25-S	SFM26-S	SFM27-S	SFM28-S	UNIT
Maximum instantaneous forward voltage at $I_F=2.0A$	$V_F$	0.95				1.25		1.70		V
Maximum reverse leakage current $T_J=25^{\circ}\text{C}$ at rated $V_R$ $T_J=125^{\circ}\text{C}$	$I_R$					5.0 100				$\mu\text{A}$ $\mu\text{A}$
Maximum reverse recovery time (Note 2)	$t_{rr}$					35				ns

### Thermal characteristics

PARAMETER	SYMBOLS	SFM21-S	SFM22-S	SFM23-S	SFM24-S	SFM25-S	SFM26-S	SFM27-S	SFM28-S	UNIT
Typical thermal resistance junction to ambient (3)	$R_{\theta JA}$					45				$^{\circ}\text{C}/\text{W}$
Typical thermal resistance junction to case(3)	$R_{\theta JC}$					26				$^{\circ}\text{C}/\text{W}$

Notes 1: Measured at 1 MHz and applied reverse voltage of 4.0 VDC

2: Measured with  $I_F = 0.5 A$ ,  $I_R = 1 A$ ,  $I_{rr} = 0.25 A$

3: Mounted on FR-4 PCB Copper, minimum recommended pad layout

## Rating and characteristic curves (SFM21-S THRU SFM28-S)

FIG.1-TYPICAL FORWARD CHARACTERISTICS

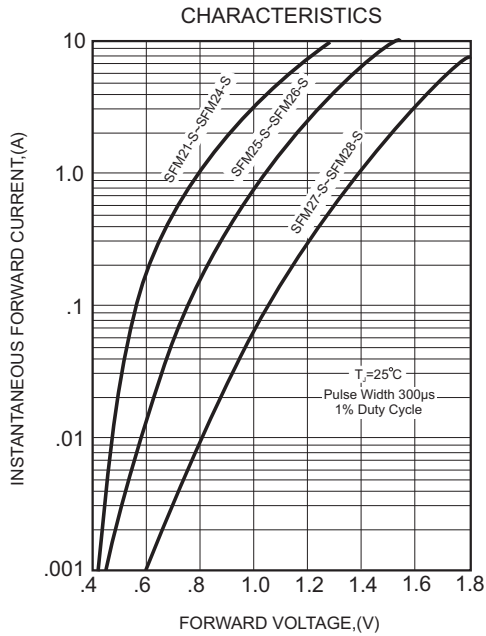

FIG.2-TYPICAL FORWARD CURRENT DERATING CURVE

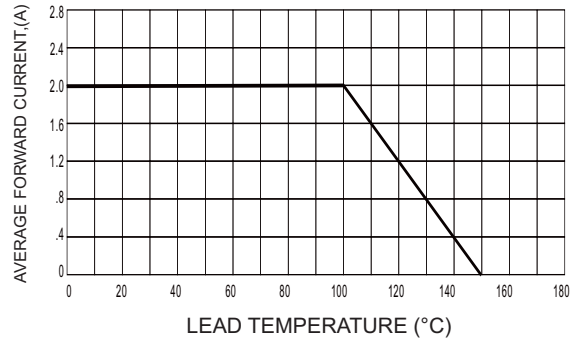
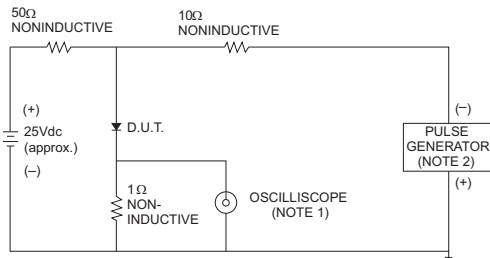

FIG.3- TEST CIRCUIT DIAGRAM AND REVERSE RECOVERY TIME CHARACTERISTICS



- NOTES: 1. Rise Time = 7ns max., Input Impedance = 1 megohm, 22pF.  
2. Rise Time = 10ns max., Source Impedance = 50 ohms.

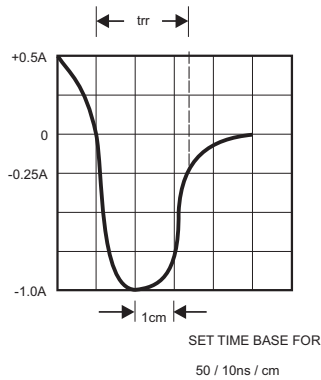

FIG.4-MAXIMUM NON-REPETITIVE FORWARD SURGE CURRENT

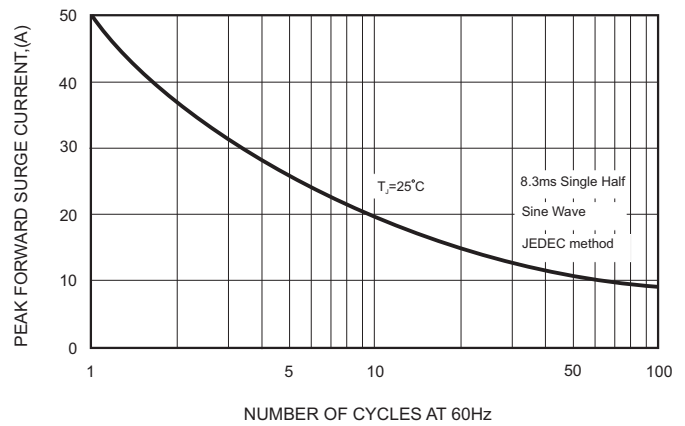
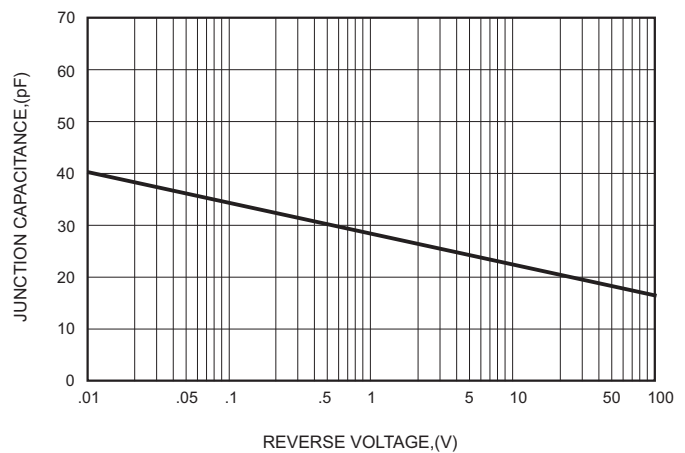



FIG.5-TYPICAL JUNCTION CAPACITANCE



# SFM21-S THRU SFM28-S

## Pinning information

Pin	Simplified outline	Symbol
Pin1 cathode Pin2 anode		

## Marking

Type number	Marking code
SFM21-S	S21
SFM22-S	S22
SFM23-S	S23
SFM24-S	S24
SFM25-S	S25
SFM26-S	S26
SFM27-S	S27
SFM28-S	S28

## Suggested solder pad layout

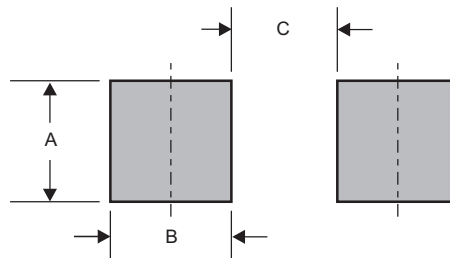

Dimensions in inches and (millimeters)

PACKAGE	A	B	C
SMA-S	0.063 (1.60)	0.059 (1.50)	0.110 (2.80)

# SFM21-S THRU SFM28-S

## Packing information

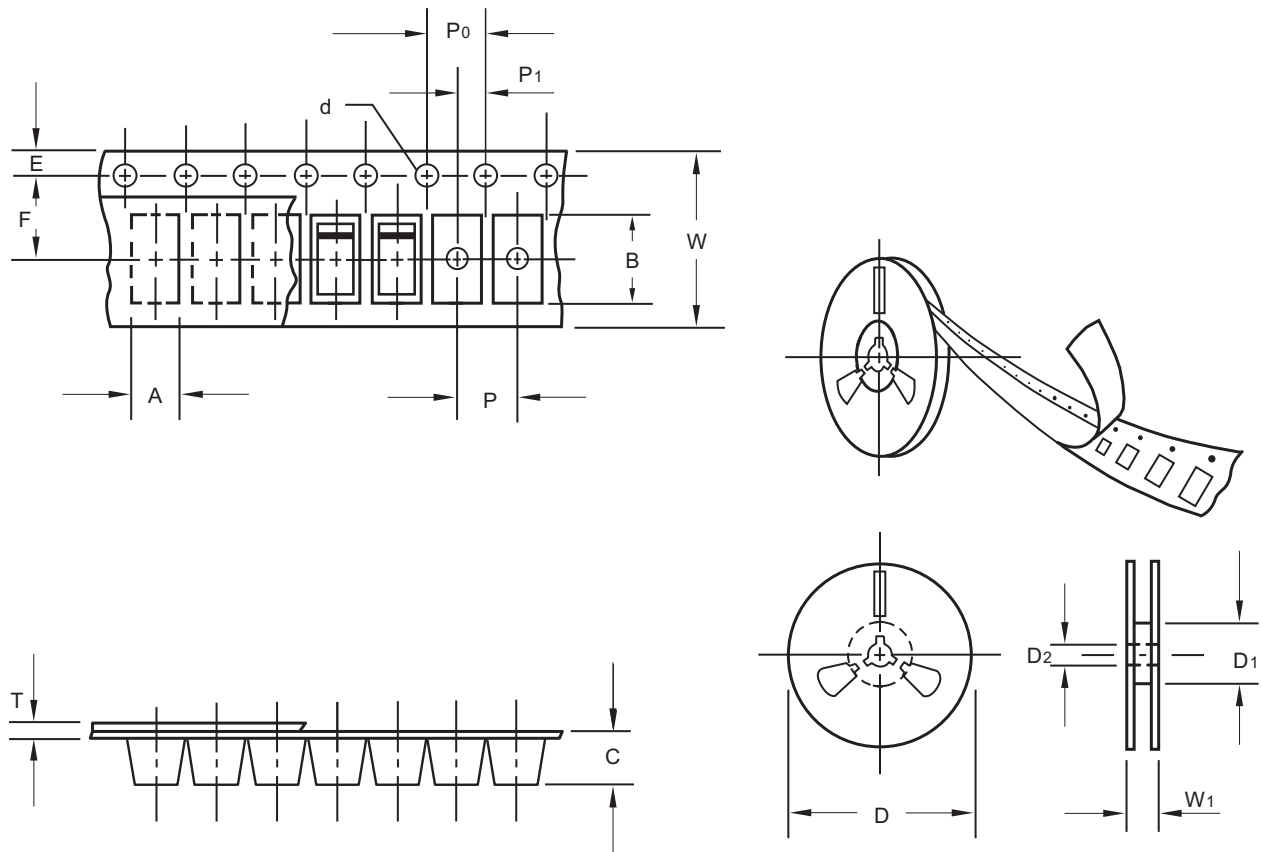

unit:mm

Item	Symbol	Tolerance	SMA-S
Carrier width	A	0.1	2.90
Carrier length	B	0.1	5.50
Carrier depth	C	0.1	2.10
Sprocket hole	d	0.1	1.50
13" Reel outside diameter	D	2.0	330.00
13" Reel inner diameter	D1	min	50.00
7" Reel outside diameter	D	2.0	178.00
7" Reel inner diameter	D1	min	62.00
Feed hole diameter	D2	0.5	13.00
Sprocket hole position	E	0.1	1.75
Punch hole position	F	0.1	5.50
Punch hole pitch	P	0.1	4.00
Sprocket hole pitch	P0	0.1	4.00
Embossment center	P1	0.1	2.00
Overall tape thickness	T	0.1	0.23
Tape width	W	0.3	12.00
Reel width	W1	1.0	18.00

Note: Devices are packed in accordance with EIA standard RS-481-A and specifications listed above.

# SFM21-S THRU SFM28-S

## Reel packing

PACKAGE	REEL SIZE	REEL (pcs)	COMPONENT SPACING (m/m)	BOX (pcs)	INNER BOX (m/m)	REEL DIA, (m/m)	CARTON SIZE (m/m)	CARTON (pcs)	APPROX. GROSS WEIGHT (kg)
SMA-S	7"	2,000	4.0	20,000	183*155*183	178	382*356*392	160,000	15.0
	13"	7,500	4.0	15,000	335*335*38	330	350*330*360	120,000	14.5

## Suggested thermal profiles for soldering processes

- 1.Storage environment: Temperature=5°C~40°C Humidity=55%±25%
- 2.Reflow soldering of surface-mount devices

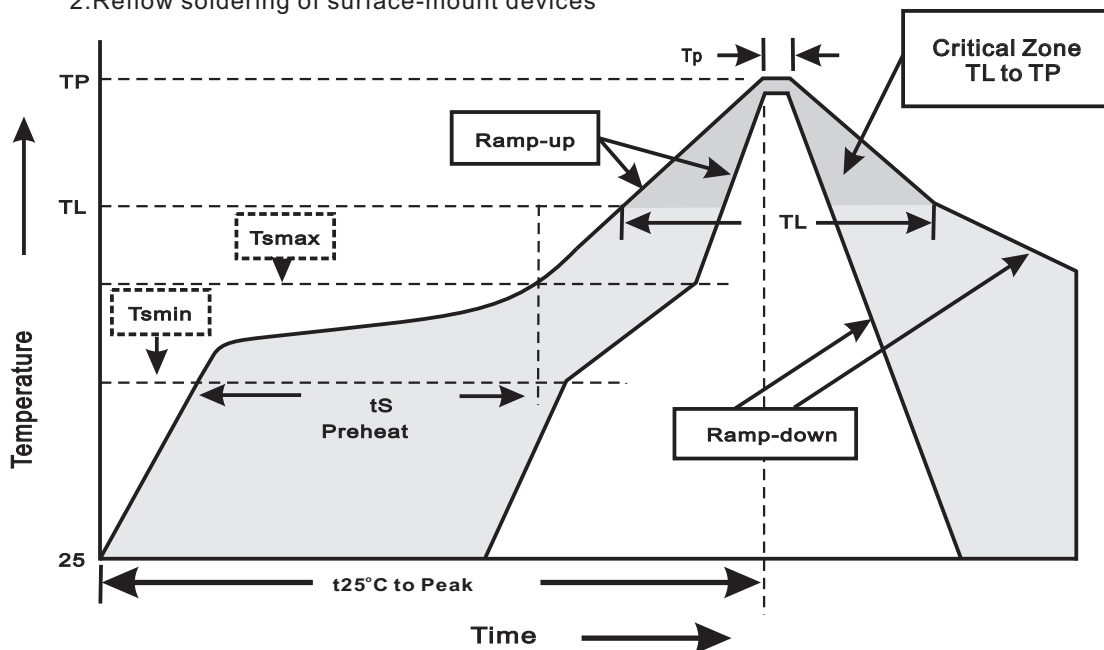

### 3.Reflow soldering

Profile Feature	Soldering Condition
Average ramp-up rate(T <sub>L</sub> to T <sub>P</sub> )	<3°C/sec
Preheat -Temperature Min(T <sub>smmin</sub> ) -Temperature Max(T <sub>smmax</sub> ) -Time(min to max)(t <sub>s</sub> )	150°C 200°C 60~120sec
T <sub>smmax</sub> to T <sub>L</sub> -Ramp-upRate	<3°C/sec
Time maintained above: -Temperature(T <sub>L</sub> ) -Time(t <sub>L</sub> )	217°C 60~260sec
Peak Temperature(T <sub>P</sub> )	255°C-0/+5°C
Time within 5°C of actual Peak Temperature(t <sub>P</sub> )	10~30sec
Ramp-down Rate	<6°C/sec
Time 25°C to Peak Temperature	<6minutes

**SFM21-S THRU SFM28-S****High reliability test capabilities**

Item Test	Conditions	Reference
1. Solder Resistance	at 260±5°C for 10±2sec.	MIL-STD-750D METHOD-2031
2. Solderability	at 245±5°C for 5 sec.	MIL-STD-202F METHOD-208
3. High Temperature Reverse Bias	$V_R=80\%$ rate at $T_J=150^\circ\text{C}$ for 168 hrs.	MIL-STD-750D METHOD-1038
4. Forward Operation Life	Rated average rectifier current at $T_A=25^\circ\text{C}$ for 500hrs.	MIL-STD-750D METHOD-1027
5. Intermittent Operation Life	$T_A = 25^\circ\text{C}$ , $I_F = I_O$ On state: power on for 5 min. off state: power off for 5 min. on and off for 500 cycles.	MIL-STD-750D METHOD-1036
6. Pressure Cooker	15P <sub>SIG</sub> at $T_A=121^\circ\text{C}$ for 4 hrs.	JESD22-A102
7. Temperature Cycling	-55°C to +125°C dwelled for 30 min. and transferred for 5min. total 10 cycles.	MIL-STD-750D METHOD-1051
8. Forward Surge	8.3ms single half sine-wave , one surge.	MIL-STD-750D METHOD-4066-2
9. Humidity	at $T_A=85^\circ\text{C}$ , RH=85% for 1000hrs.	MIL-STD-750D METHOD-1021
10. High Temperature Storage Life	at 175°C for 1000 hrs.	MIL-STD-750D METHOD-1031