

1.2MHz 2A, High Voltage, Boost Converter

❖ GENERAL DESCRIPTION

The MA2009 is a current mode step up converter intended for small, low power applications. The converter input voltage ranging from 2.6V to 16V. The Output voltage can be set up to 28V. The frequency is 1.2MHz allows the use of small external inductors and capacitors and provides fast transient response. Internal soft start results in small inrush current and extends battery life. Internal power MOSFET with very low RDS (ON) provides high efficiency. The MA2009 automatically transits from PWM to PFM during light load condition further increasing efficiency. The converter also provides protection functions such as under-voltage lockout, current limit and thermal shutdown. The MA2009 is available in 6-pin SOT23 packages.

❖ FEATURES

- 2.6V to 16V operating input voltage range
- 1.2MHz Fixed Switching Frequency
- Adjustable output voltage range up to 28V
- Internal 3A switching current limit
- Up to 97% Efficiency
- Internal Soft-start Function and compensation
- Current limit and Thermal shutdown protection
- Under voltage Lockout
- Available in the 6-pin SOT23 Packages

❖ APPLICATIONS

- Battery-Powered Equipment
- Set-Top Boxed
- LCD Bias Supply
- PDA, DVD and GPS Receivers
- Portable Instruments

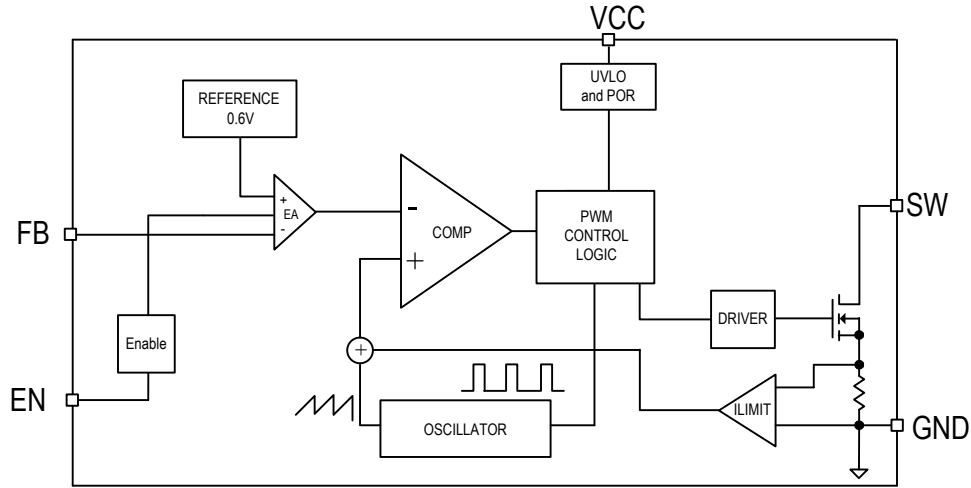
❖ BLOCK DIAGRAM

❖ PIN ASSIGNMENT

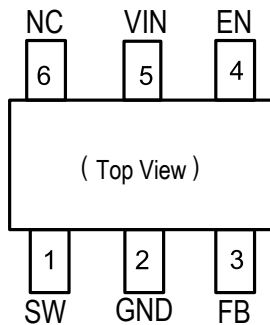
The package of MA2009 is SOT23-6L; the pin assignment is given by:



Name	Description
SW	Power Switch Output. SW is the drain of the internal MOSFET switch. Connect the power inductor and output rectifier to SW. SW can swing between GND and 28V.
GND	Ground Pin.
FB	Feedback Input. The FB voltage is 0.6V. Connect a resistor divider to FB.
EN	Regulator On/Off Control Input. A high input at EN turns on the converter,
VIN	Input Supply Pin.

❖ ORDER/MARKING INFORMATION

Order Information	Top Marking
<p>MA2009 X X</p> <p>Package Type: C: SOT23-6L</p> <p>Packing: Blank : Bag, A : Taping</p>	<p>B 2 Y W X → ID Code: Internal</p> <p>Week: 01~26(A~Z), 27~52(a~z)</p> <p>Year : 6 = 2016</p>

❖ ABSOLUTE MAXIMUM RATINGS (at $T_A=25^{\circ}\text{C}$)

Characteristics	Symbol	Rating	Unit
VIN,EN pin voltage		-0.3 to 20	V
SW pin voltage	V_{SW}	-0.3 to 30	V
FB pins voltage		-0.3 to 6	V
Continuous Power Dissipation	PD	$(T_J - T_A) / \theta_{JA}$	mW
Operating Temperature	Top	-40 to 85	$^{\circ}\text{C}$
Junction Temperature	T_J	150	$^{\circ}\text{C}$
Storage Temperature Range		-65 to 150	$^{\circ}\text{C}$
Thermal Resistance from Junction to case	θ_{JC}	110	$^{\circ}\text{C}/\text{W}$
Thermal Resistance from Junction to ambient	θ_{JA}	250	$^{\circ}\text{C}/\text{W}$

Note: θ_{JA} is measured with the PCB copper are (need connect to GND) of approximately 1 in² (Multi-layer).

❖ ELECTRICAL CHARACTERISTICS

($V_{IN} = 5\text{V}$, $V_{EN} = 5\text{V}$, $T_A = 25^{\circ}\text{C}$)

Characteristics	Symbol	Conditions	Min	Typ	Max	Units
Input Voltage Range	V_{IN}		2.6	-	16	V
Input UVLO	UVLO	Rising	-	1.7	2.55	V
UVLO Hysteresis			-	0.1	-	V
Step-Up Voltage Adjust Range	V_{OUT}		3	-	28	V
Quiescent Current	I_{CCQ}	$I_{OUT} = 0\text{mA}$, $V_{FB} = 0.7\text{V}$	-	100	200	μA
Shutdown Current	I_{SD}	$V_{EN} = 0\text{V}$	-	0.1	1	μA
FB Pin Voltage	V_{FB}		0.588	0.600	0.612	V
Switching frequency	F_{OSC}		800	1200	1500	KHz
Maximum Duty	D_{MAX}		88	90	-	%
SW current limit(Note 1)	I_{LIM}	Duty=50%	3	4	-	A
MOSFET on-resistance(Note 1)	$R_{DS(on)}$	$V_{CC} = 5\text{V}$, $I_{SW} = 1\text{A}$	-	80	150	m Ω
SW Leakage Current	I_{SWL}	$V_{SW} = 28\text{V}$, $V_{FB} = 0.7\text{V}$	-	-	1	μA
EN high-level input voltage	V_{IH}		1.5	-	-	V
EN low-level input voltage	V_{IL}		-	-	0.4	V
Thermal Shutdown	T_{DS}		-	150	-	$^{\circ}\text{C}$

Note1: Guaranteed by design, not tested.

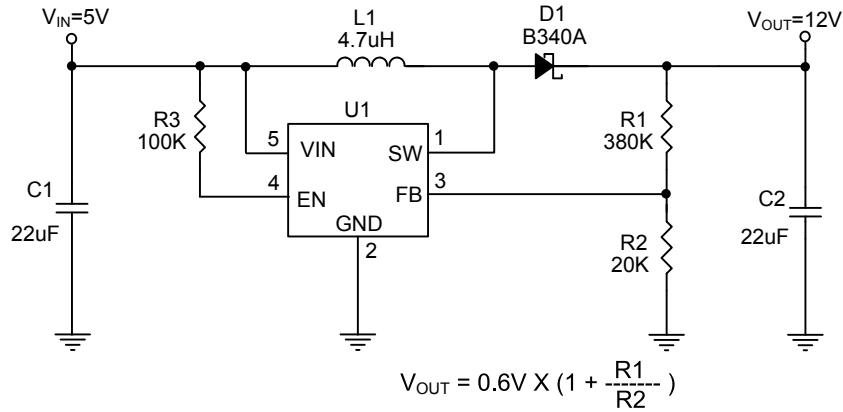
❖ APPLICATION CIRCUIT

❖ FUNCTION DESCRIPTION

The MA2009 uses a fixed frequency, peak current mode boost regulator architecture to regulate voltage at the feedback pin. The operation of the MA2009 can be understood by referring to the block diagram of Block Diagram item. At the start of each oscillator cycle the MOSFET is turned on through the control circuitry. To prevent sub-harmonic oscillations at duty cycles greater than 50 percent, a stabilizing ramp is added to the output of the current sense amplifier and the result is fed into the negative input of the PWM comparator. When this voltage equals the output voltage of the error amplifier the power MOSFET is turned off. The voltage at the output of the error amplifier is an amplified version of the difference between the 0.6V band-gap reference voltage and the feedback voltage. In this way the peak current level keeps the output in regulation. If the feedback voltage starts to drop, the output of the error amplifier increases. These results in more current to flow through the power MOSFET, thus increasing the power delivered to the output. The MA2009 has internal soft start to limit the amount of input current at startup and to also limit the amount of overshoot on the output.

❖ APPLICATION INFORMATION

Setting the Output Voltage

Application circuit item shows the basic application circuit with MA2009 adjustable output version. The external resistor sets the output voltage according to the following equation:

$$V_{OUT} = 0.6V \times \left(1 + \frac{R1}{R2}\right)$$

Table 1—Resistor Selection for Common Output Voltages

V _{OUT} (V)	R2 (kΩ)	R1 (kΩ)
5	20	147
12	20	380
16	20	515
24	20	780

Input and Output Capacitor Selection

Input and output ceramic capacitors of 22μF are recommended for MA2009 applications. For better voltage filtering, ceramic capacitors with low ESR are recommended. X5R and X7R types are suitable because of their wider voltage and temperature ranges.

Inductor Selection

The recommended values of inductor are 4.7 to 22μH. Small size and better efficiency are the major concerns for portable device, such as MA2009 used for mobile phone. The inductor should have low core loss at 1.2MHz and low DCR for better efficiency. To avoid inductor saturation current rating should be considered.

Schottky diode Selection

Schottky diode is a good choice for MA2009 because of its low forward voltage drop and fast reverse recovery. Using Schottky diode can get better efficiency. The high speed rectification is also a good characteristic of Schottky diode for high switching frequency. Current rating of the diode must meet the root mean square of the peak current and output average current multiplication as following:

$$I_D(RMS) \approx \sqrt{I_{OUT} \times I_{PEAK}}$$

The diode's reverse breakdown voltage should be larger than the output voltage.

PCB Layout Recommendations

When laying out the printed circuit board, the following checking should be used to ensure proper operation of the MA2009. Check the following in your layout:

1. The power traces, consisting of the GND trace, the SW trace and the VIN trace should be kept short, direct and wide.
2. Does the (+) plates of C1 connect to VIN as closely as possible. This capacitor provides the AC current to the internal power MOSFETs.
3. Keep the switching node SW away from the sensitive VOUT node.
4. Keep the (-) plates of C1 and C2 as close as possible.

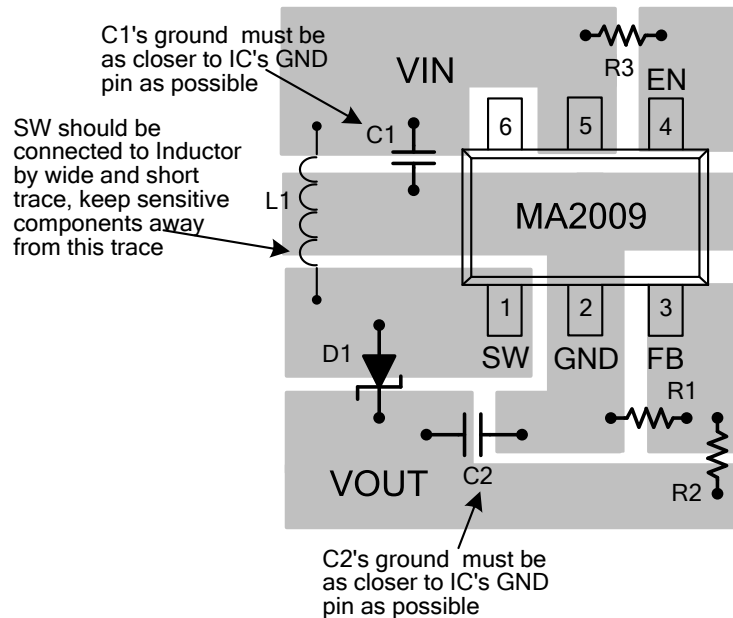

❖ TYPICAL CHARACTERISTICS

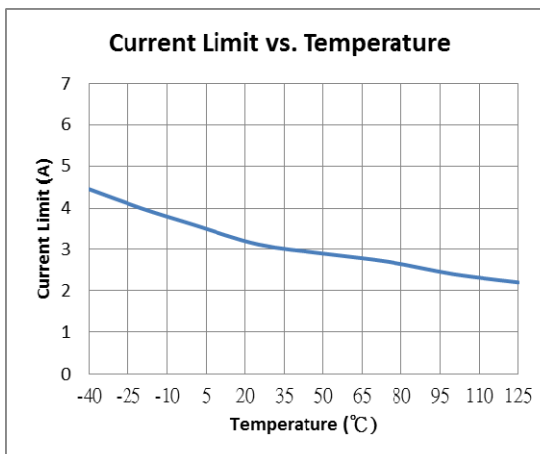
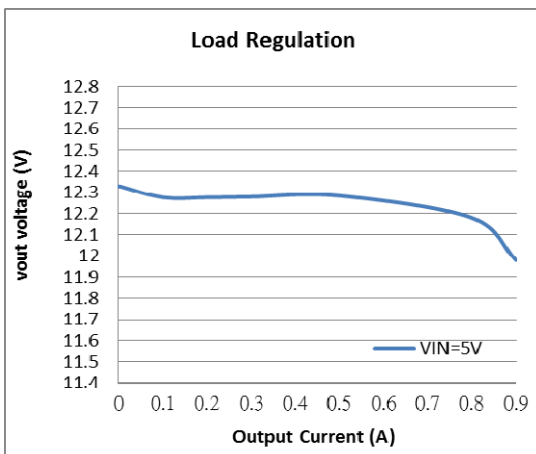
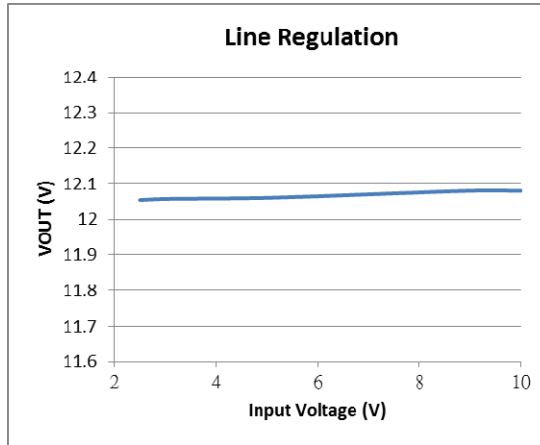
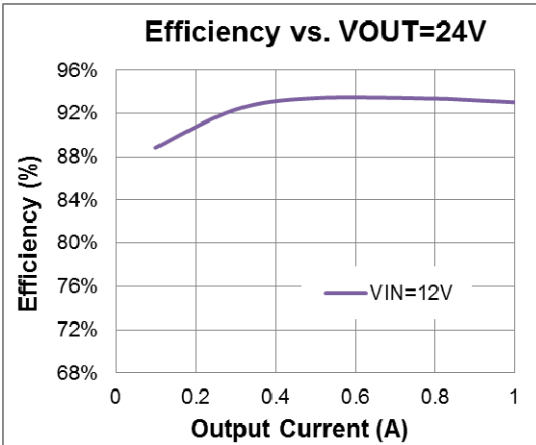
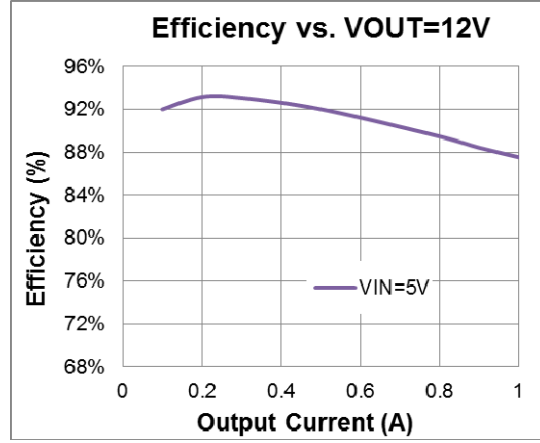
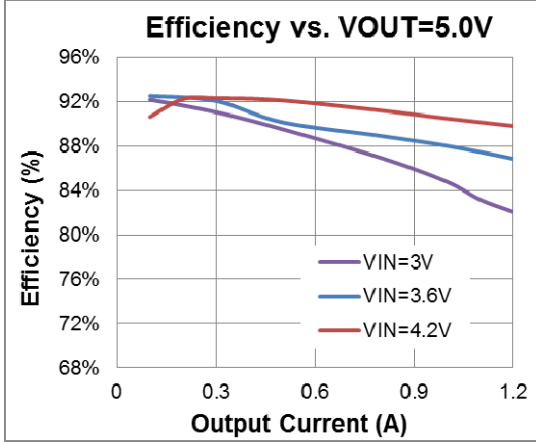

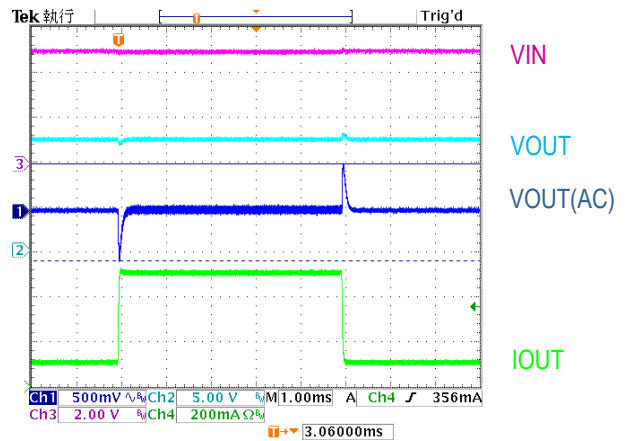
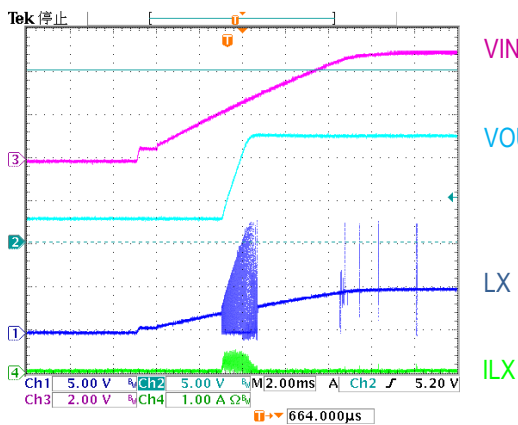
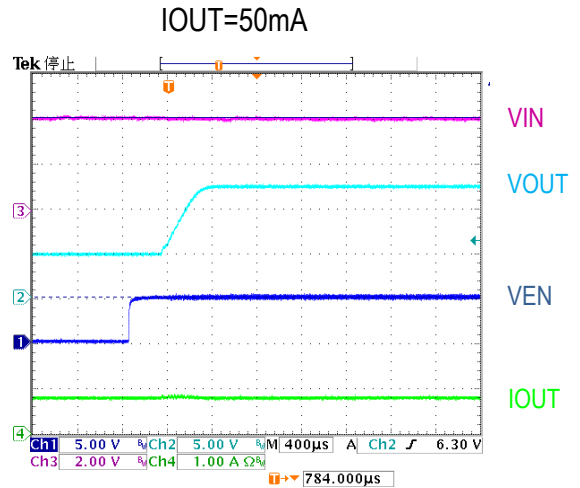
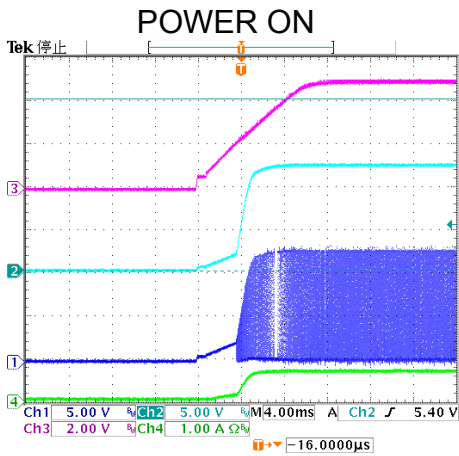
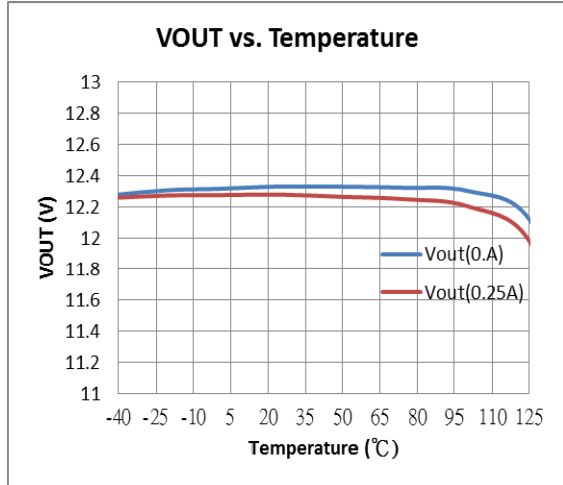
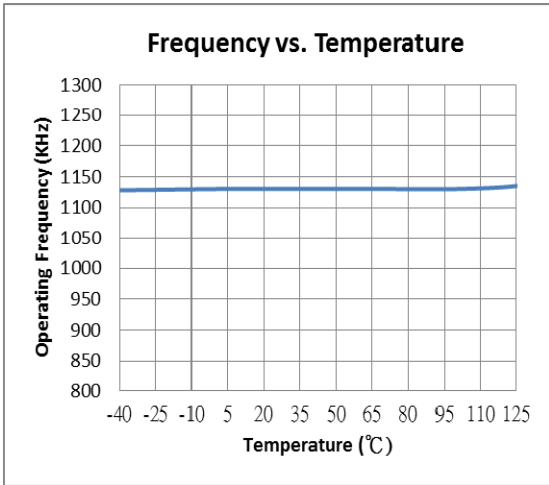

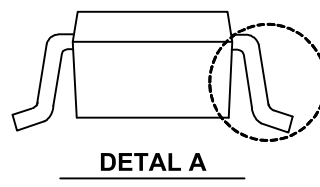
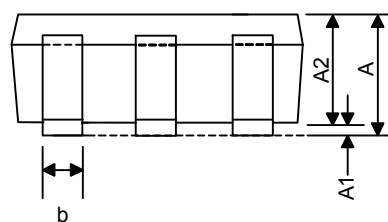
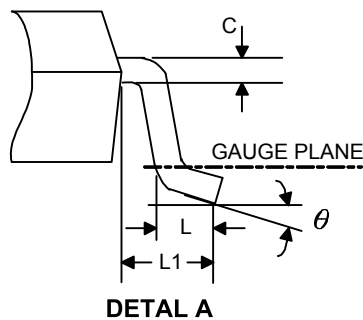
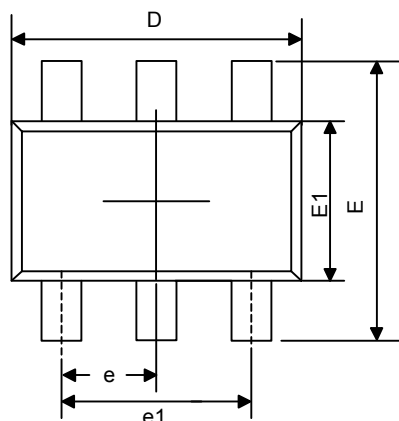
❖ Package Outlines

Symbol	Dimensions in Millimeters			Dimensions in Inches		
	Min.	Nom.	Max.	Min.	Nom.	Max.
A	1.05	-	1.45	0.041	-	0.057
A1	0.05	-	2.15	0.002	-	0.085
A2	0.90	1.10	1.30	0.035	0.043	0.051
b	0.30	-	0.50	0.012	-	0.020
C	0.08	-	0.22	0.003	-	0.009
D	2.70	2.90	3.10	0.106	1.114	0.122
E1	1.40	1.60	1.80	0.055	0.063	0.071
E	2.60	2.80	3.00	0.102	0.110	0.118
L	0.30	-	0.60	0.012	-	0.024
L1	0.50	0.60	0.70	0.020	0.024	0.028
e1	1.80	1.90	2.00	0.071	0.075	0.079
e	0.85	1.00	1.15	0.033	0.037	0.045
θ	0°	4°	8°	0°	4°	8°