

Feature

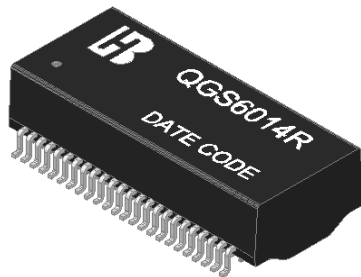

- Design for 2.5G/5G ethernet application.
- Complying with IEEE 802.3at standard.
- POE applications with 600mA current capability.
- Complying with ROHS & Halogen Free requirements.
- Operating temperature range: 0°C to +70°C.
- Storage temperature range: -25°C to +85°C.

Electrical Specifications @ 25°C

Part Number	Turns Ratio (±5%)		OCL (uH Min) @100KHz/0.1V	L.L (uH Max)	C _{ww} (pF Max)	DCR (Ω Max)	HI-POT
	TX	RX					
QGS6014R	1CT:1CT	1CT:1CT	180	0.5	28	0.9	AC1500V/1mA

Continue

Part Number	Insertion Loss (dB Max)		Return Loss (dB Min) @ Load 100Ω	
	1 ≤ f ≤ 100 MHz	100 < f ≤ 250 MHz	1 ≤ f ≤ 40 MHz	40 < f ≤ 250 MHz
QGS6014R	-1.0	-2.0	-16	-(16-10 log ₁₀ (f/40))

Continue

Part Number	Cross talk (dB Min)		DCMR (dB Min)		
	1 ≤ f ≤ 100 MHz	100 < f ≤ 250 MHz	1 < f ≤ 30 MHz	30 < f ≤ 250 MHz	
QGS6014R	$20 \log_{10} \left[10^{\frac{35.3 - 15 \log_{10}(f/100)}{-20}} + 2 \times 10^{\frac{43 - 20 \log_{10}(f/100)}{-20}} \right]$		-30	-48	-(44-19.2 log ₁₀ (f/50))

Schematic

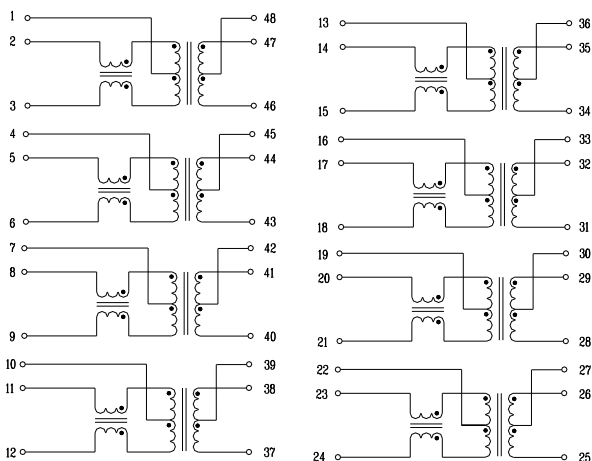

Mechanical

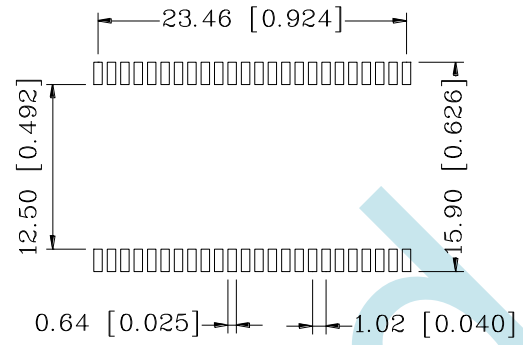
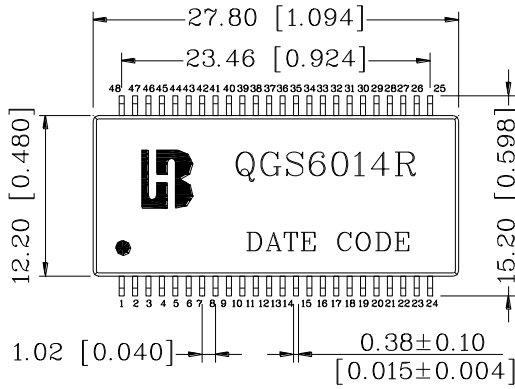

SUGGESTED PAD LAYOUT

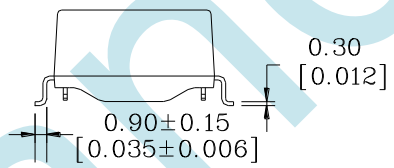
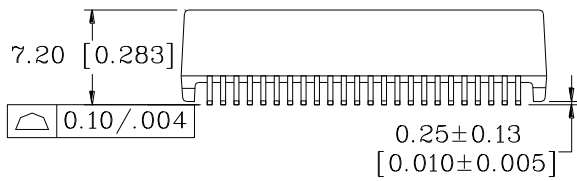

Units: mm [Inches] Tolerance: xx.xx ± 0.25 [0.010]
 0.xx ± 0.05 [0.002]

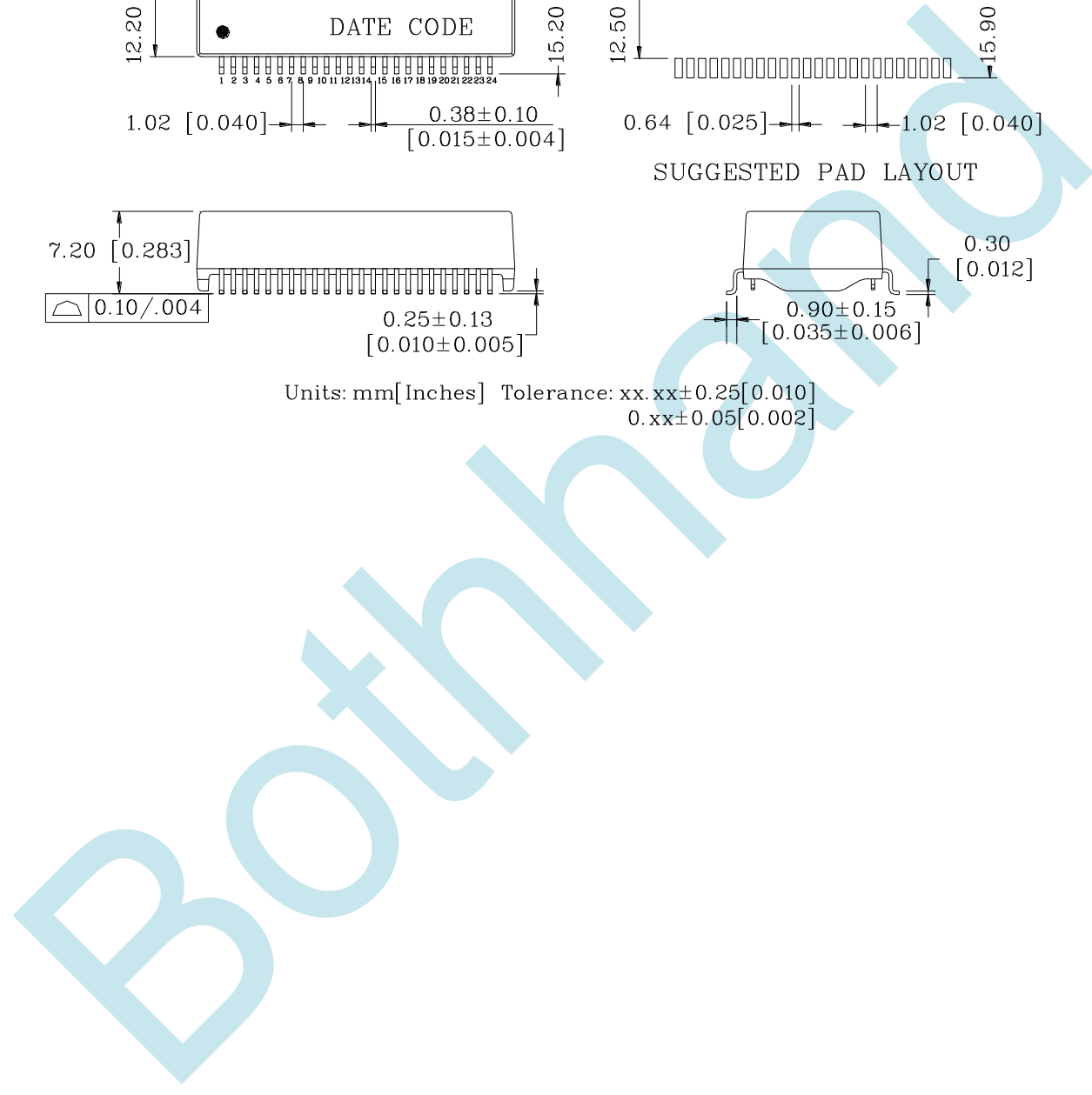

REEL PACKAGE

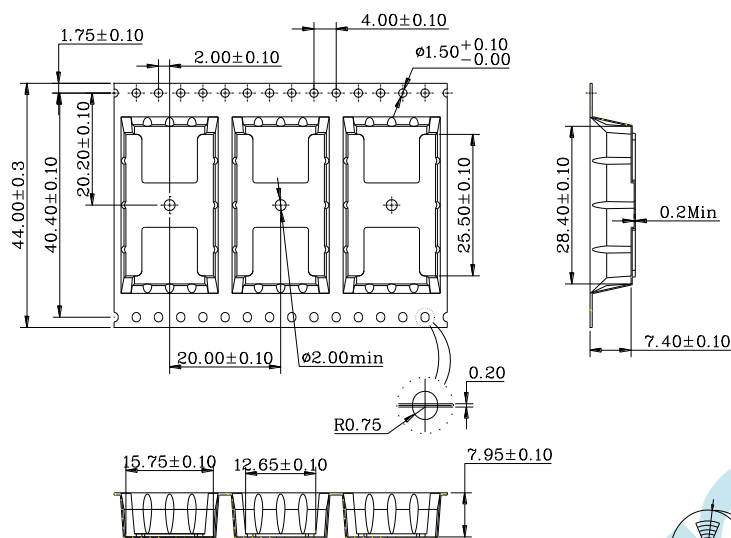

1. 10 sprocket hole pitch cumulative tolerance ±0.20
2. Carrier camber is within 1 mm in 250mm
3. Material :Black Anti-Static polystyrene.
4. All dimensions meet EIA-481-B requirements
5. Thickness :0.40±0.05mm
6. Component load per 13" reel :350pcs
7. Packing length per 22" reel: 25.1 Meters
8. comply with Bothhand's <BHKP-WI-44-005> requirements

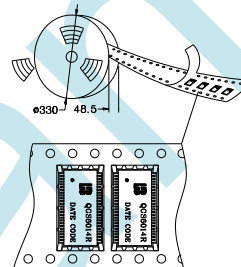

CARTON PACKAGE

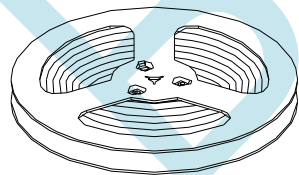

REEL

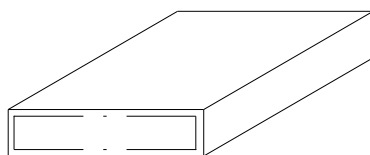

INNER BOX: 347x347x82

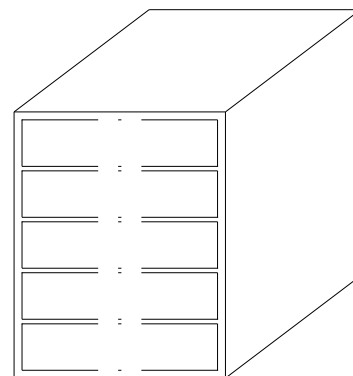

OUTER CARTON: 375x375x470

1. 1 Reel=350PCS
2. 1 INNER BOX=1 Reel=350 PCS
3. 1 OUTER CARTON=5 INNER BOX=5*350=1750 PCS