

Aug.1.2022 Copyright 2022 HIROSE ELECTRIC CO., LTD. All Rights Reserved.
 In case of consideration for using Automotive equipment / device which demand high reliability, kindly contact our sales window correspondents.

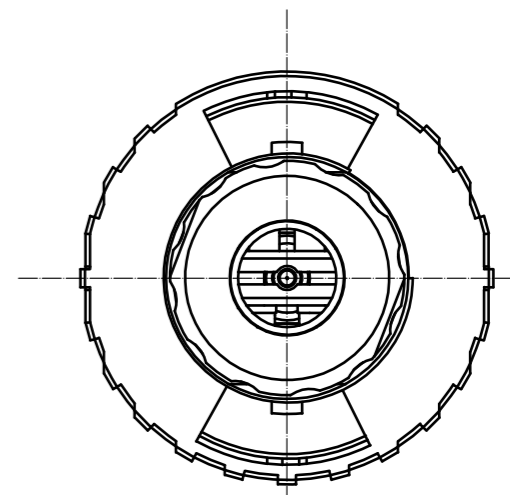

A - A

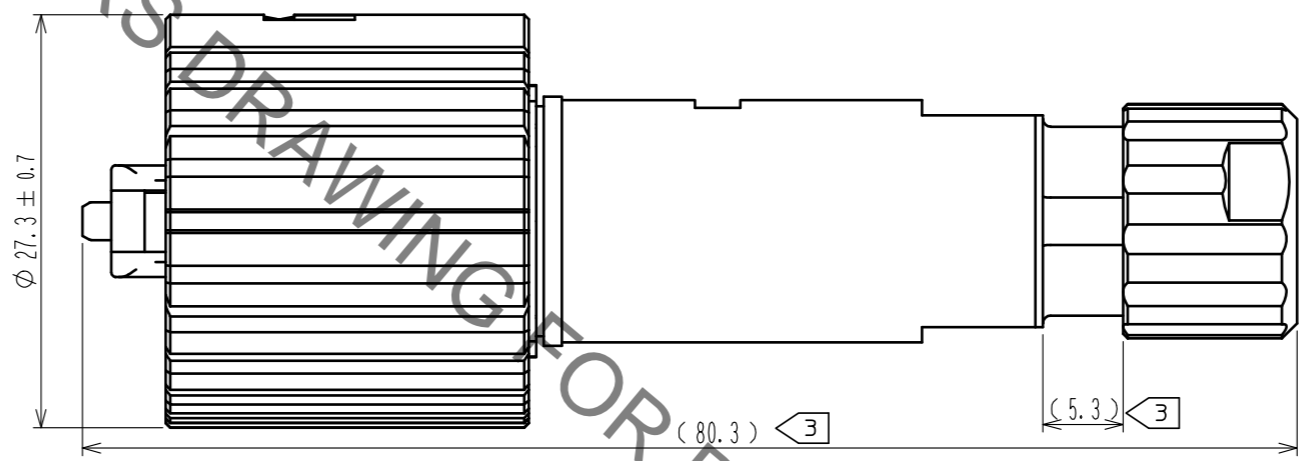
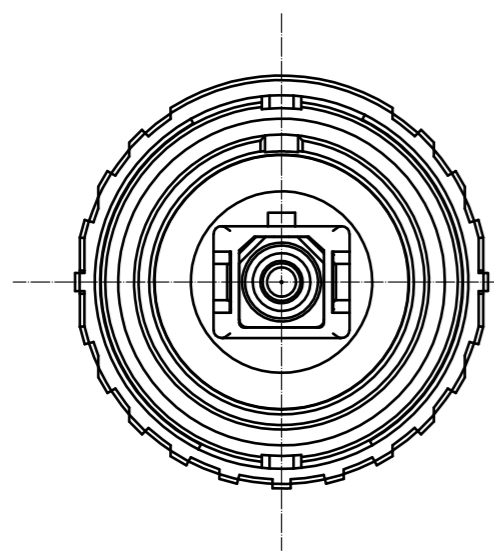
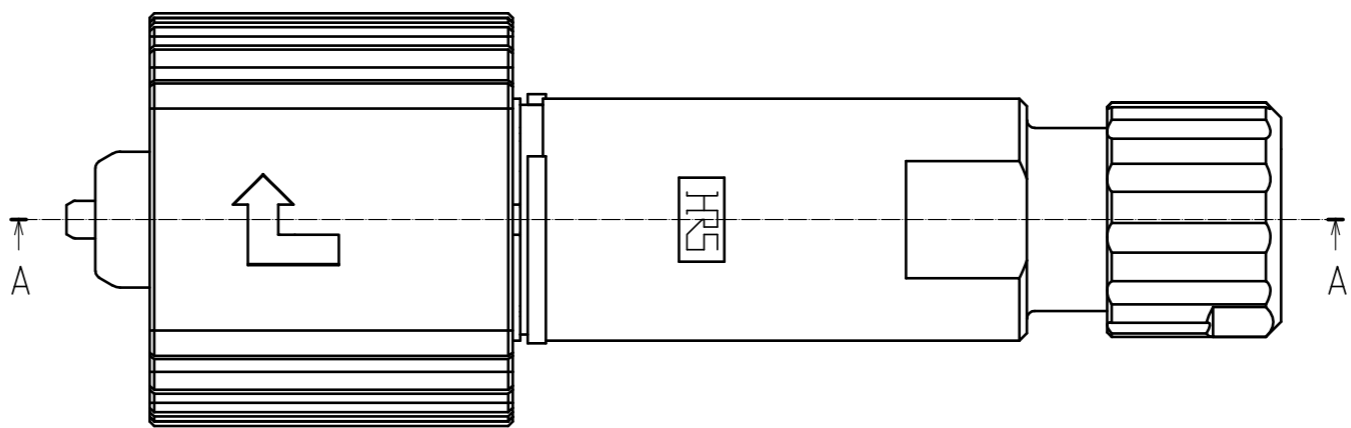
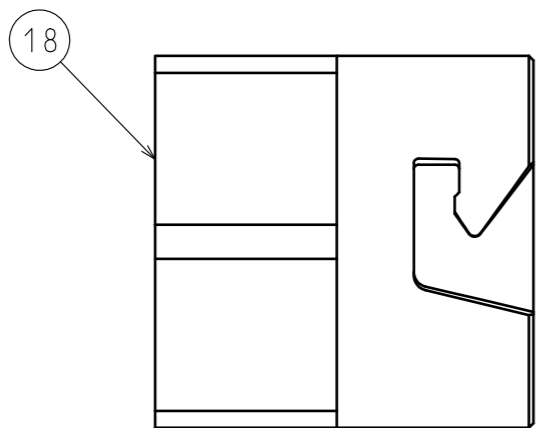
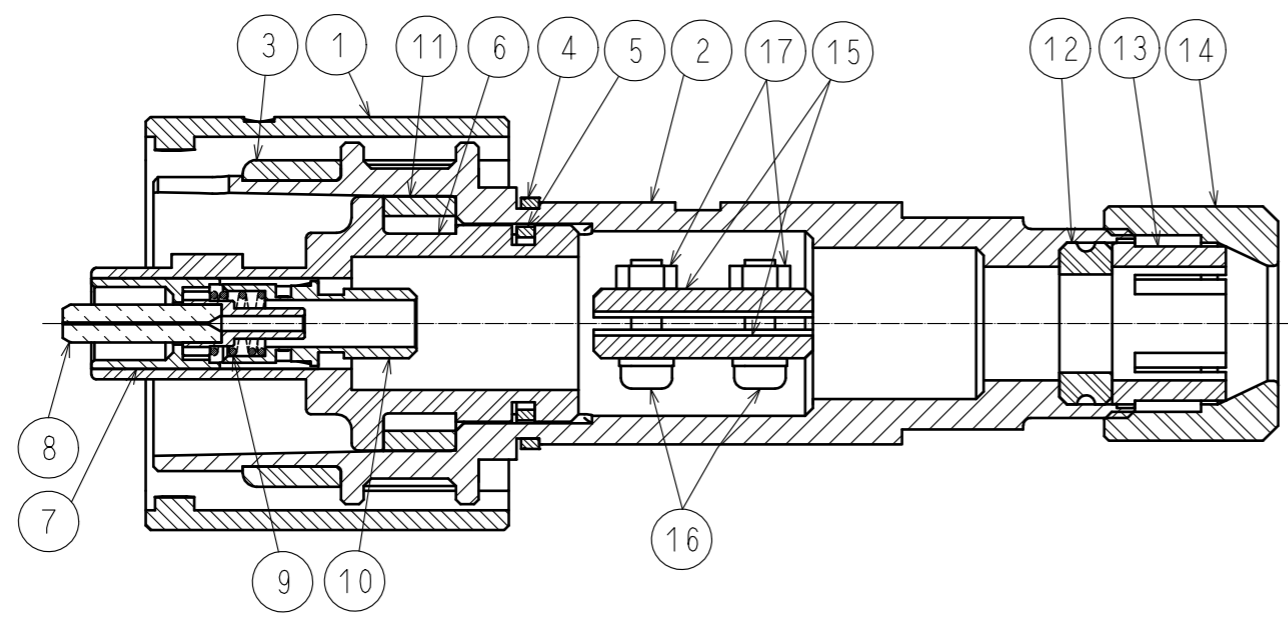

NOTE 1. Compliant with ROHS.
 2. This drawing shows the configuration of assembly. But the product is not assembled, on delivery.
 3. The values in parentheses are for reference.
 4. We will change the resin material manufacturer for part number 6.7 between 2019 and 2022 in order to continue the stable supply of this product. Thank you for your understanding. There is no change in product specification (quality difference) due to a change in material manufacturer.

9	Stainless steel	Spring	18	POM resin	Color : Black. Cap
8	ZrO ₂ Stainless Steel	Zirconia Ferrule	17	Stainless steel	M2 hexagonal nut . 4 pcs.
7	PBT resin	Color : White	16	Stainless steel	M2 screw with spring washer . 4 pcs.
6	PBT resin	Color : Blue	15	Zinc alloy die casting	Nickel plating. 2 pcs.
5	Phosphorus bronze	Nickel plating	14	PPS resin	Color : Blown
4	Phosphorus bronze	Nickel plating	13	PA resin	Color : White
3	Silicone rubber	Hardness: 70 deg. Color: Black	12	Silicon rubber	Hardness: 70 deg. Frosted. Bore diameter: $\phi 6.6$
2	Zinc alloy die casting	Chrome plating. Color : Black	11	Steel wire	Spring
1	Zinc alloy die casting	Chrome plating. Color : Black	10	PBT resin	Color : Black
NO.	MATERIAL	FINISH . REMARKS	NO.	MATERIAL	FINISH . REMARKS

UNITS mm		SCALE 2 : 1	COUNT 1	DESCRIPTION OF REVISIONS DIS-K-00003095	DESIGNED TY. SATO	CHECKED SJ. SUZUKI	DATE 20210319
HRS HIROSE ELECTRIC CO., LTD.		APPROVED : MT. SHIBUTANI	20141201	DRAWING NO. EDC3-177045-01			
		CHECKED : YY. HIYAMA	20141201	PART NO. SW20-SCPT75-2(22)			
		DESIGNED : FS. YOSHIDA	20141201	CODE NO. CL0717-5019-5-22			
		DRAWN : FS. YOSHIDA	20141201			1/1	