

Features

- Glass Passivated Die Construction
- 30000W Peak Pulse Power Dissipation
- 28V – 288V Standoff Voltage
- Uni- and Bi-Directional Versions Available
- Excellent Clamping Voltage
- Typical Response Time < 1nS
- Plastic Case Material has UL Flammability Classification Rating 94V-0

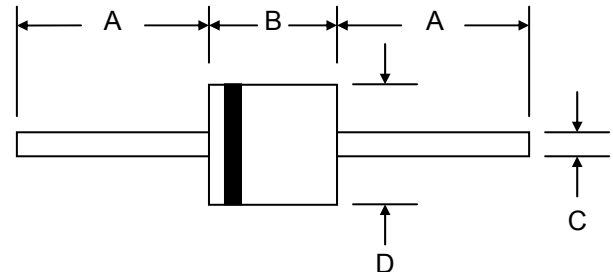

Mechanical Data

- Case: P-600, Molded Plastic
- Terminals: Plated Leads Solderable per MIL-STD-202, Method 208
- Polarity: Cathode Band Except Bi-Directional
- Weight: 2.10 grams (approx.)
- Mounting Position: Any
- Marking: Type Number
- **Lead Free: For RoHS / Lead Free Version, Add "-LF" Suffix to Part Number, See Page 5**

P-600		
Dim	Min	Max
A	25.4	—
B	8.60	9.10
C	1.20	1.30
D	8.60	9.10
All Dimensions in mm		

Maximum Ratings and Electrical Characteristics @ $T_A=25^\circ\text{C}$ unless otherwise specified

Characteristic	Symbol	Value	Unit
Peak Pulse Power Dissipation on 10/1000 μS Waveform (Note 1, 2, 4)	PPPM	30000	W
Peak Pulse Current on 10/1000 μS Waveform (Note 1)	IPPM	See Table 1	A
Peak Forward Surge Current (Note 2, 3)	IFSM	400	A
Power Dissipation at $T_L = 75^\circ\text{C}$ (Note 2)	P_D	8.0	W
Typical Thermal Resistance, Junction to Ambient (Note 2)	R_{JA}	40	$^\circ\text{C}/\text{W}$
Typical Thermal Resistance, Junction to Lead (Note 2)	R_{JL}	8.0	$^\circ\text{C}/\text{W}$
Operating and Storage Temperature Range	T_J, T_{STG}	-55 to +150	$^\circ\text{C}$

- Note: 1. Non-repetitive current pulse per Figure 5 and derated above $T_A = 25^\circ\text{C}$ per Figure 1.
 2. Mounted on 20 x 20 x 1.0mm thick copper pads to each terminal that maintained at a distance of 9.5mm from the case.
 3. Measured on 8.3ms single half sine-wave, duty cycle = 4 pulses per minute maximum. For uni-directional devices only.
 4. Peak pulse power waveform is 10/1000 μS .

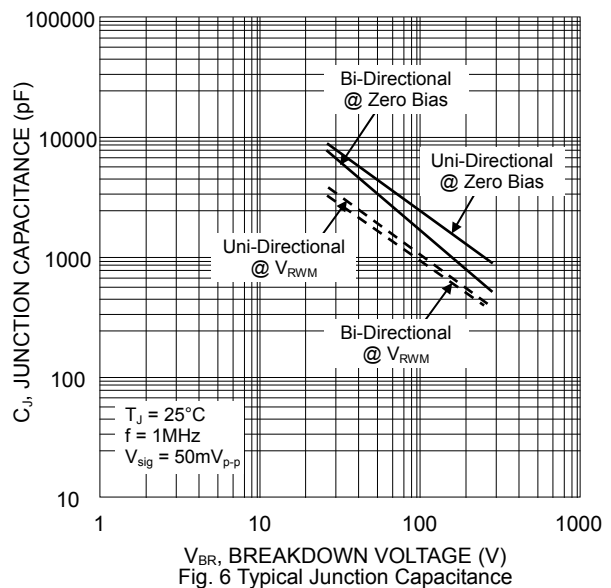
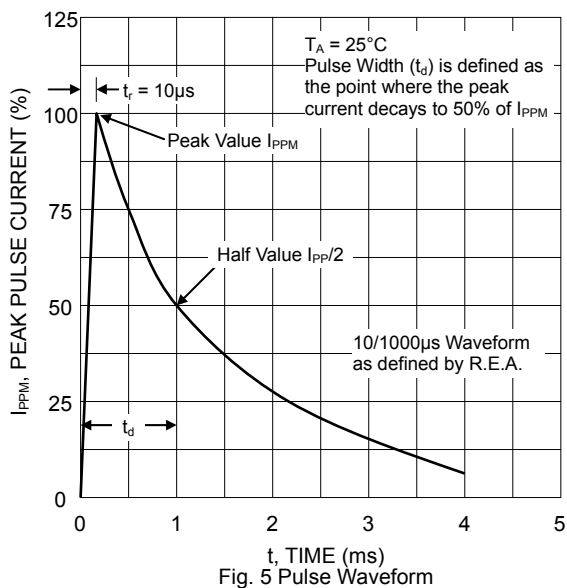
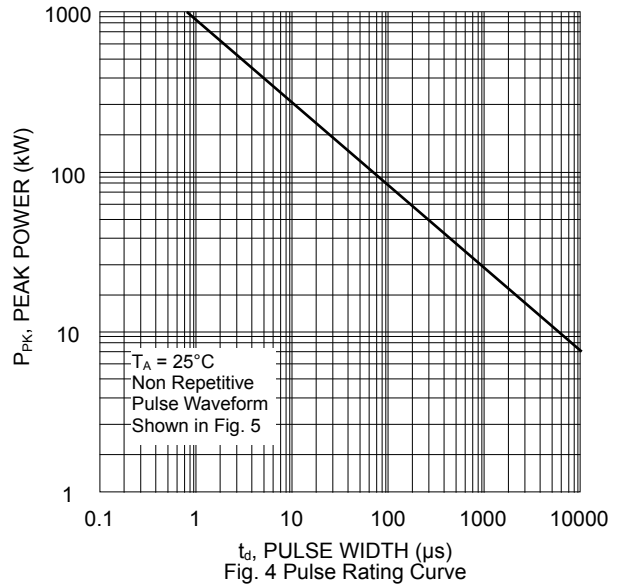
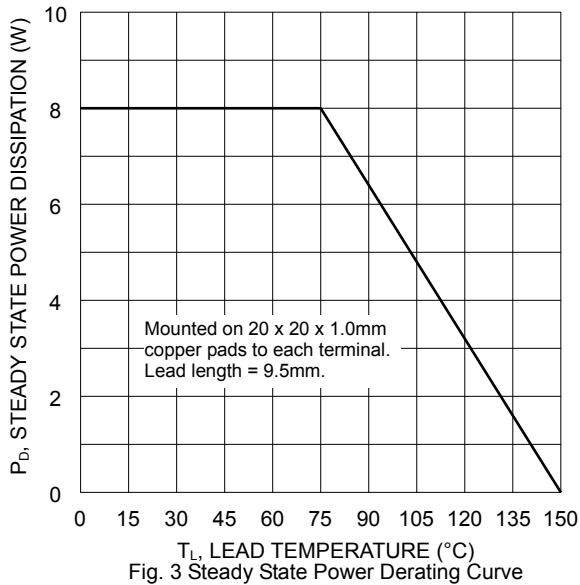
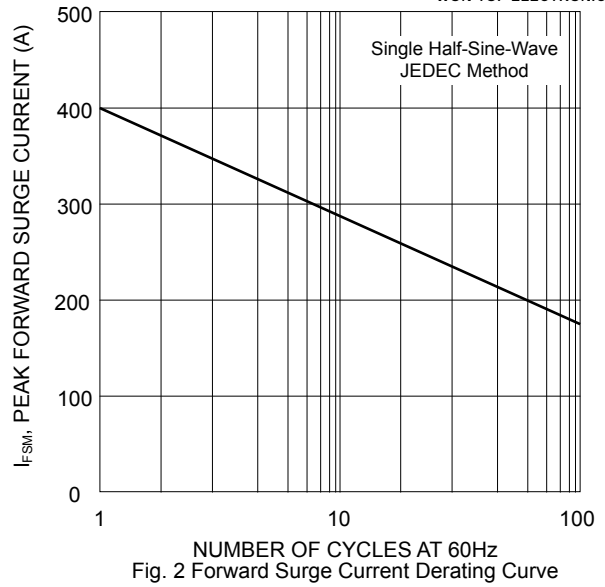
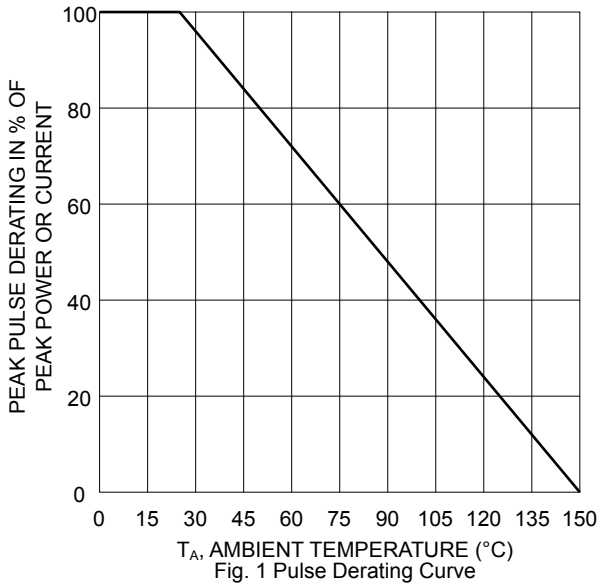

Electrical Characteristics (@T_A=25°C unless otherwise specified) Table 1

Uni-Directional Part No.	Bi-Directional Part No.	Reverse Stand-Off Voltage V _{RWM} (V)	Breakdown Voltage V _{BR} (V) @I _T	Test Current I _T (mA)	Maximum Clamping Voltage @I _{PP} V _C (V)	Peak Pulse Current I _{PP} (A)	Reverse Leakage* @V _{RWM} I _R (μA)
			Min.				
30KP28A	30KP28CA	28.0	31.28	50	50.0	606.0	5000
30KP30A	30KP30CA	30.0	33.51	50	55.2	548.9	5000
30KP33A	30KP33CA	33.0	36.90	50	58.5	517.9	5000
30KP36A	30KP36CA	36.0	40.20	50	61.8	490.3	5000
30KP39A	30KP39CA	39.0	43.60	20	67.2	450.9	2000
30KP42A	30KP42CA	42.0	46.90	10	72.0	420.8	1000
30KP43A	30KP43CA	43.0	48.00	10	73.0	415.1	1000
30KP45A	30KP45CA	45.0	50.30	5	77.4	391.5	250
30KP48A	30KP48CA	48.0	53.60	5	81.6	371.3	150
30KP51A	30KP51CA	51.0	57.00	5	86.4	350.7	50
30KP54A	30KP54CA	54.0	60.30	5	91.4	331.5	20
30KP58A	30KP58CA	58.0	64.80	5	92.4	327.9	20
30KP60A	30KP60CA	60.0	67.00	5	102.0	297.1	15
30KP64A	30KP64CA	64.0	71.50	5	104.0	291.3	10
30KP66A	30KP66CA	66.0	73.70	5	107.0	283.2	2
30KP70A	30KP70CA	70.0	78.20	5	109.0	278.0	2
30KP71A	30KP71CA	71.0	79.30	5	111.5	271.7	2
30KP72A	30KP72CA	72.0	80.40	5	114.0	265.8	2
30KP75A	30KP75CA	75.0	83.80	5	119.4	253.8	2
30KP78A	30KP78CA	78.0	87.10	5	129.0	234.9	2
30KP84A	30KP84CA	84.0	93.80	5	139.2	217.7	2
30KP90A	30KP90CA	90.0	100.50	5	146.4	207.0	2
30KP96A	30KP96CA	96.0	107.20	5	156.0	194.2	2
30KP102A	30KP102CA	102.0	113.90	5	165.6	183.0	2
30KP108A	30KP108CA	108.0	120.60	5	175.2	172.9	2
30KP120A	30KP120CA	120.0	134.00	5	194.4	155.9	2
30KP132A	30KP132CA	132.0	147.40	5	213.0	142.3	2
30KP144A	30KP144CA	144.0	160.80	5	223.2	135.8	2
30KP150A	30KP150CA	150.0	167.60	5	233.4	129.8	2
30KP156A	30KP156CA	156.0	174.30	5	245.0	123.7	2
30KP160A	30KP160CA	160.0	178.70	5	252.6	120.0	2
30KP168A	30KP168CA	168.0	187.70	5	272.4	111.2	2
30KP170A	30KP170CA	170.0	189.90	5	275.0	110.2	2
30KP180A	30KP180CA	180.0	201.10	5	290.4	104.3	2
30KP198A	30KP198CA	198.0	221.20	5	319.8	94.7	2
30KP216A	30KP216CA	216.0	241.30	5	348.6	86.9	2
30KP240A	30KP240CA	240.0	268.10	5	387.0	78.3	2
30KP258A	30KP258CA	258.0	288.20	5	416.4	72.8	2
30KP260A	30KP260CA	260.0	290.40	5	416.0	72.8	2
30KP270A	30KP270CA	270.0	301.60	5	436.2	69.5	2
30KP280A	30KP280CA	280.0	312.80	5	464.0	65.3	2
30KP288A	30KP288CA	288.0	321.70	5	469.9	64.5	2

*For bi-directional devices V_{RWM} ≤ 60V, the I_R limit is double.

MARKING INFORMATION

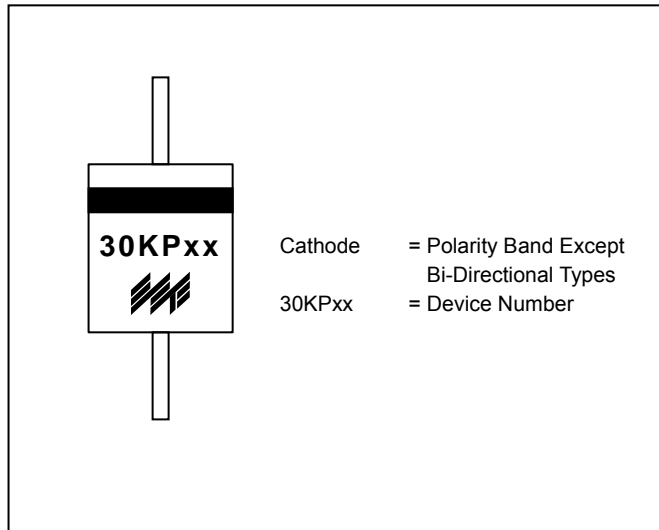

TAPING SPECIFICATIONS

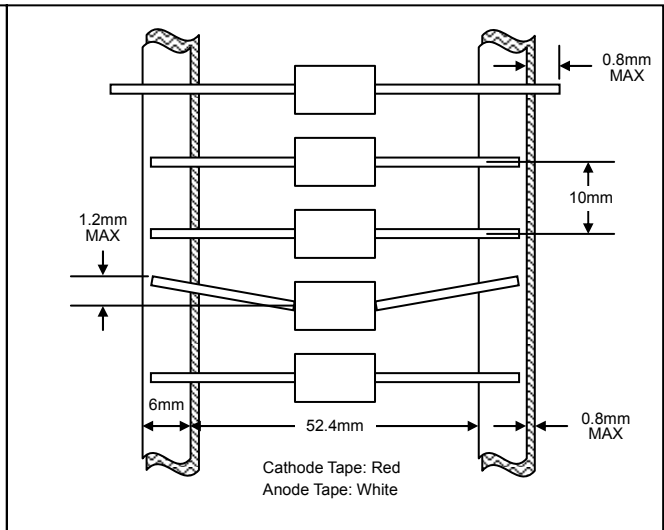

PACKAGING INFORMATION

TAPE & REEL

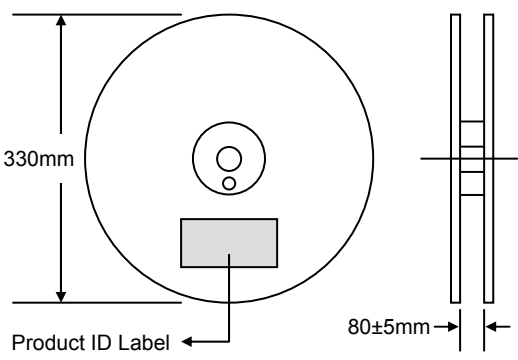

330mm

Product ID Label

80±5mm

BULK

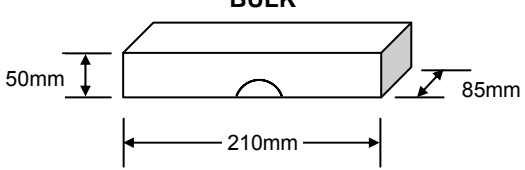

50mm

210mm

85mm

Packaging	Reel Diameter / Box Size (mm)	Quantity (PCS)	Carton Size (mm)	Quantity (PCS)	Approx. Gross Weight (KG)
TAPE & REEL	330	800	370 x 370 x 420	4,000	12.0
BULK	210 x 85 x 50	250	500 x 255 x 275	7,000	17.0

Note: 1. Paper reel, white or gray color. Core material: plastic or metal.
2. Components are packed in accordance with EIA standard RS-296-E.

ORDERING INFORMATION

Product No.	Package Type	Shipping Quantity
30KPxx-T3	P-600	800/Tape & Reel
30KPxx	P-600	250 Units/Box

1. Products listed in **bold** are WTE **Preferred** Devices.
2. Shipping quantity given is for minimum packing quantity only. For minimum order quantity, please consult the Sales Department.
3. **To order RoHS / Lead Free version (with Lead Free finish), add "-LF" suffix to part number above. For example, 30KP28A-T3-LF.**

WON-TOP ELECTRONICS and  are registered trademarks of Won-Top Electronics Co., Ltd (WTE). WTE has checked all information carefully and believes it to be correct and accurate. However, WTE cannot assume any responsibility for inaccuracies. Furthermore, this information does not give the purchaser of semiconductor devices any license under patent rights to manufacturer. WTE reserves the right to change any or all information herein without further notice.

WARNING: DO NOT USE IN LIFE SUPPORT EQUIPMENT. WTE power semiconductor products are not authorized for use as critical components in life support devices or systems without the express written approval.

Won-Top Electronics Co., Ltd.
No. 44 Yu Kang North 3rd Road,
Chine Chen Dist., Kaohsiung 806, Taiwan
Phone: 886-7-822-5408 or 886-7-822-5410
Fax: 886-7-822-5417
Email: sales@wontop.com
Internet: <http://www.wontop.com>

We power your everyday.