

HFM201-L THRU HFM207-L

List

List.....	1
Package outline.....	2
Features.....	2
Mechanical data.....	2
Maximum ratings and Electrical characteristics	2
Rating and characteristic curves.....	3
Pinning information.....	4
Marking.....	4
Suggested solder pad layout.....	4
Packing information.....	5
Reel packing.....	6
Suggested thermal profiles for soldering processes.....	6
High reliability test capabilities.....	7

HFM201-L THRU HFM207-L

2.0A Surface Mount High Efficiency Rectifiers 50V-1000V

Features

- Batch process design, excellent power dissipation offers better reverse leakage current and thermal resistance
- Low profile surface mounted application in order to optimize board space
- High current capability
- Ultrafast recovery time for high efficiency
- High surge current capability
- Glass passivated chip junction
- Lead-free parts meet RoHS requirements
- Suffix "-H" indicates Halogen free parts, ex. HFM201-L-H

Mechanical data

- Epoxy:UL94-V0 rated flame retardant
- Case : Molded plastic, SMA-L
- Terminals : Solder plated, solderable per MIL-STD-750, Method 2026
- Polarity : Indicated by cathode band
- Mounting Position : Any
- Weight : Approximated 0.05 gram

Package outline

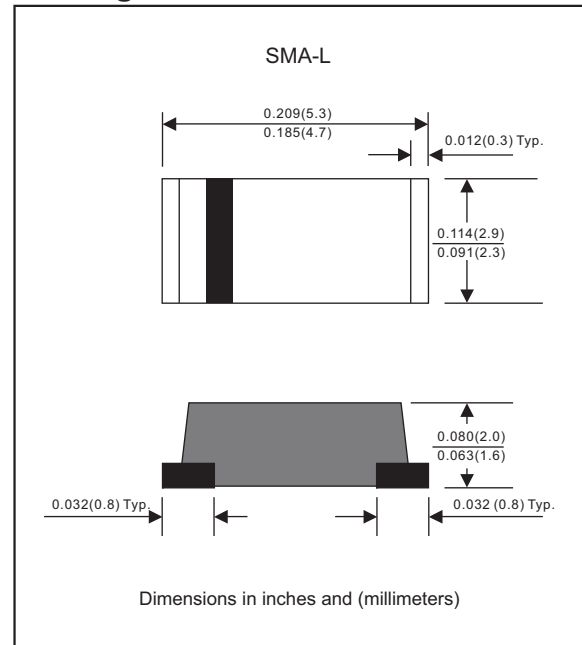

Maximum ratings (AT $T_A=25^{\circ}\text{C}$ unless otherwise noted)

PARAMETER	SYMBOLS	HFM201-L	HFM202-L	HFM203-L	HFM204-L	HFM205-L	HFM206-L	HFM207-L	UNIT
Maximum repetitive peak reverse voltage	V_{RRM}	50	100	200	400	600	800	1000	V
Maximum RMS voltage	V_{RMS}	35	70	140	280	420	560	700	V
Maximum continuous reverse voltage	V_R	50	100	200	400	600	800	1000	V
Maximum average forward rectified current	I_o	2.0							A
Non-repetitive peak forward surge current 8.3ms single half sine-wave	I_{FSM}	50							A
Typical junction capacitance (Note 1)	C_J	25							pF
Operating junction temperature range	T_J	-55 to +150							$^{\circ}\text{C}$
Storage temperature range	T_{STG}	-65 to +175							$^{\circ}\text{C}$

Electrical characteristics (AT $T_A=25^{\circ}\text{C}$ unless otherwise noted)

PARAMETER	SYMBOLS	HFM201-L	HFM202-L	HFM203-L	HFM204-L	HFM205-L	HFM206-L	HFM207-L	UNIT	
Maximum instantaneous forward voltage at $I_F=2.0\text{A}$	V_F	1.00			1.30	1.70			V	
Maximum reverse leakage current $T_J=25^{\circ}\text{C}$ at rated V_R $T_J=125^{\circ}\text{C}$	I_R	5.0 150							μA μA	
Maximum reverse recovery time (Note 2)	t_{rr}	50				75				ns

Thermal characteristics

PARAMETER	SYMBOLS	HFM201-L	HFM202-L	HFM203-L	HFM204-L	HFM205-L	HFM206-L	HFM207-L	UNIT
Typical thermal resistance junction to ambient (Note 3)	$R_{\theta JA}$	56							$^{\circ}\text{C}/\text{W}$
Typical thermal resistance junction to case (Note 3)	$R_{\theta JC}$	46							$^{\circ}\text{C}/\text{W}$

Notes 1: Measured at 1 MHz and applied reverse voltage of 4.0 VDC

2: Measured with $I_F = 0.5\text{A}$, $I_R = 1\text{A}$, $I_{rr} = 0.25\text{A}$

3: Mounted on FR-4 PCB Copper, minimum recommended pad layout



Rating and characteristic curves (HFM201-L THRU HFM207-L)

FIG.1-TYPICAL FORWARD CHARACTERISTICS

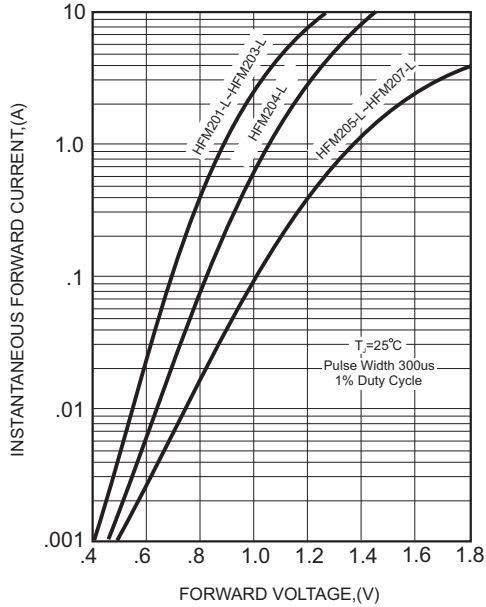

FIG.2-TYPICAL FORWARD CURRENT DERATING CURVE

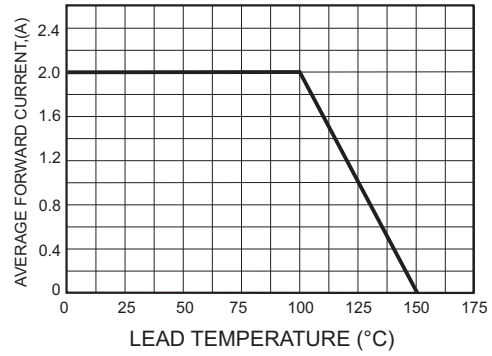

FIG.4-MAXIMUM NON-REPETITIVE FORWARD SURGE CURRENT

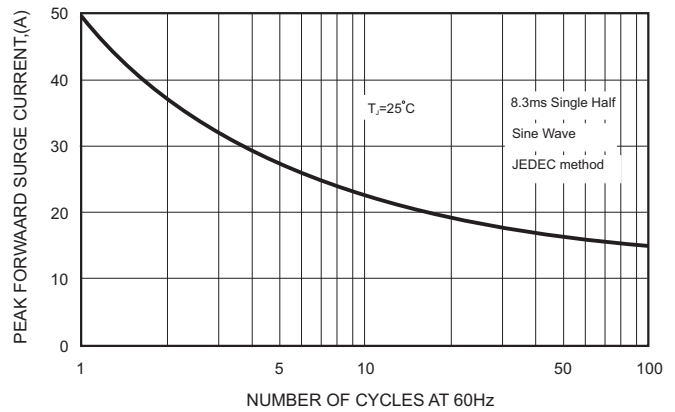
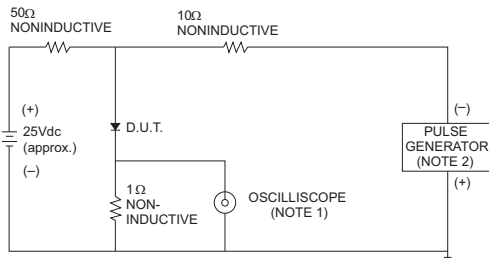

FIG.3- TEST CIRCUIT DIAGRAM AND REVERSE RECOVERY TIME CHARACTERISTICS



- NOTES: 1. Rise Time= 7ns max., Input Impedance= 1 megohm,22pF.
2. Rise Time= 10ns max., Source Impedance= 50 ohms.

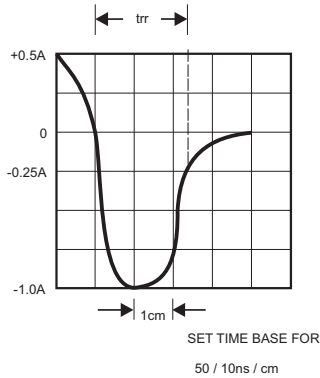
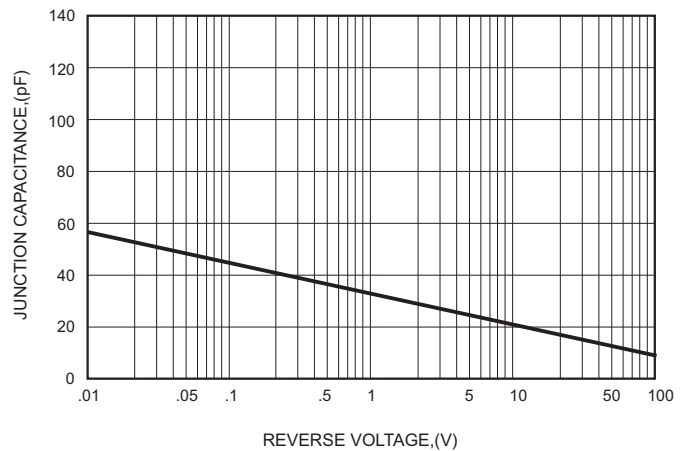



FIG.5-TYPICAL JUNCTION CAPACITANCE



HFM201-L THRU HFM207-L

Pinning information

Pin	Simplified outline	Symbol
Pin1 cathode Pin2 anode		

Marking

Type number	Marking code
HFM201-L	H21
HFM202-L	H22
HFM203-L	H23
HFM204-L	H24
HFM205-L	H25
HFM206-L	H26
HFM207-L	H27

Suggested solder pad layout

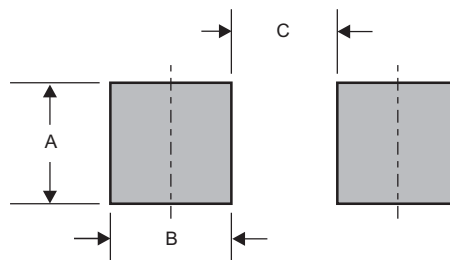

Dimensions in inches and (millimeters)

PACKAGE	A	B	C
SMA-L	0.110 (2.80)	0.059 (1.50)	0.110 (2.80)

HFM201-L THRU HFM207-L

Packing information

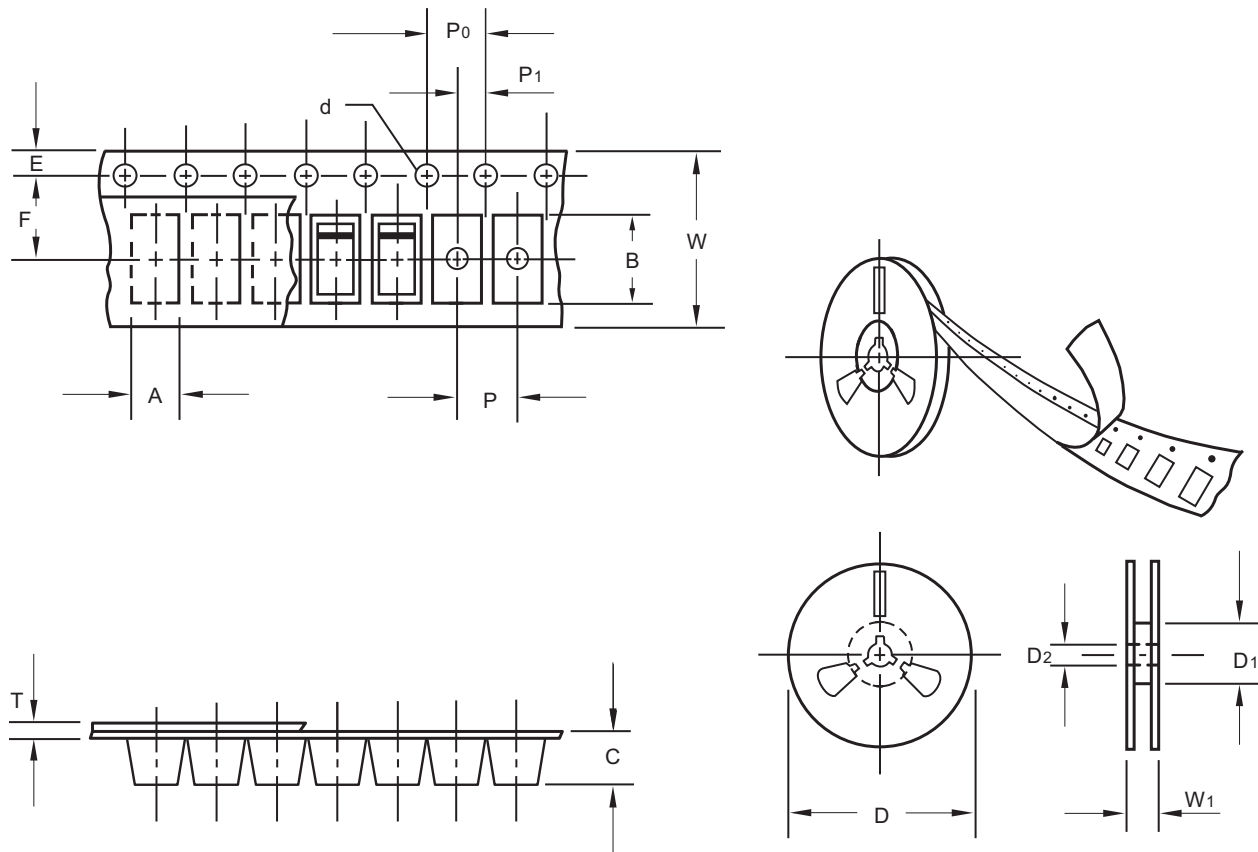

unit:mm

Item	Symbol	Tolerance	SMA-L
Carrier width	A	0.1	2.90
Carrier length	B	0.1	5.50
Carrier depth	C	0.1	2.10
Sprocket hole	d	0.1	1.50
13" Reel outside diameter	D	2.0	330.00
13" Reel inner diameter	D1	min	50.00
7" Reel outside diameter	D	2.0	178.00
7" Reel inner diameter	D1	min	62.00
Feed hole diameter	D2	0.5	13.00
Sprocket hole position	E	0.1	1.75
Punch hole position	F	0.1	5.50
Punch hole pitch	P	0.1	4.00
Sprocket hole pitch	P0	0.1	4.00
Embossment center	P1	0.1	2.00
Overall tape thickness	T	0.1	0.23
Tape width	W	0.3	12.00
Reel width	W1	1.0	18.00

Note: Devices are packed in accordance with EIA standard RS-481-A and specifications listed above.

HFM201-L THRU HFM207-L

Reel packing

PACKAGE	REEL SIZE	REEL (pcs)	COMPONENT SPACING (m/m)	BOX (pcs)	INNER BOX (m/m)	REEL DIA, (m/m)	CARTON SIZE (m/m)	CARTON (pcs)	APPROX. GROSS WEIGHT (kg)
SMA-L	7"	2,000	4.0	20,000	183*155*183	178	382*356*392	160,000	15.5
	7"	2,000	4.0	10,000	180*180*80	178	440*410*220	100,000	13.0

Suggested thermal profiles for soldering processes

- 1.Storage environment: Temperature=5°C~40°C Humidity=55%±25%
- 2.Reflow soldering of surface-mount devices

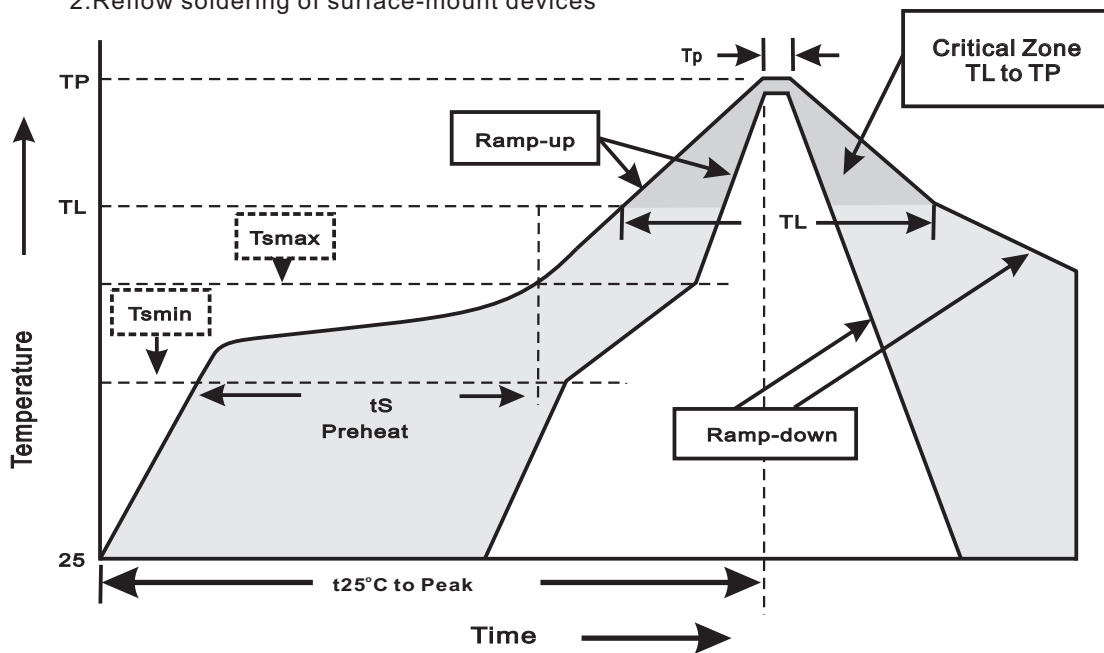

3.Reflow soldering

Profile Feature	Soldering Condition
Average ramp-up rate(T _L to T _P)	<3°C/sec
Preheat -Temperature Min(T _{min}) -Temperature Max(T _{max}) -Time(min to max)(t _s)	150°C 200°C 60~120sec
T _{max} to T _L -Ramp-upRate	<3°C/sec
Time maintained above: -Temperature(T _L) -Time(t _L)	217°C 60~260sec
Peak Temperature(T _P)	255°C-0/+5°C
Time within 5°C of actual Peak Temperature(t _P)	10~30sec
Ramp-down Rate	<6°C/sec
Time 25°C to Peak Temperature	<6minutes

HFM201-L THRU HFM207-L

High reliability test capabilities

Item Test	Conditions	Reference
1. Solder Resistance	at 260±5°C for 10±2sec.	MIL-STD-750D METHOD-2031
2. Solderability	at 245±5°C for 5 sec.	MIL-STD-202F METHOD-208
3. High Temperature Reverse Bias	$V_R=80\%$ rate at $T_J=150^\circ\text{C}$ for 168 hrs.	MIL-STD-750D METHOD-1038
4. Forward Operation Life	Rated average rectifier current at $T_A=25^\circ\text{C}$ for 500hrs.	MIL-STD-750D METHOD-1027
5. Intermittent Operation Life	$T_A = 25^\circ\text{C}$, $I_F = I_O$ On state: power on for 5 min. off state: power off for 5 min. on and off for 500 cycles.	MIL-STD-750D METHOD-1036
6. Pressure Cooker	15P _{SIG} at $T_A=121^\circ\text{C}$ for 4 hrs.	JESD22-A102
7. Temperature Cycling	-55°C to +125°C dwelled for 30 min. and transferred for 5min. total 10 cycles.	MIL-STD-750D METHOD-1051
8. Forward Surge	8.3ms single half sine-wave , one surge.	MIL-STD-750D METHOD-4066-2
9. Humidity	at $T_A=85^\circ\text{C}$, RH=85% for 1000hrs.	MIL-STD-750D METHOD-1021
10. High Temperature Storage Life	at 175°C for 1000 hrs.	MIL-STD-750D METHOD-1031