

1.5A Low Dropout Positive Regulator

FEATURES

- Dropout Voltage 1.3V at 1.5A Output Current.
- Fast Transient Response.
- Line Regulation, typical at 0.015%.
- Load Regulation, typical at 0.1%.
- Current Limiting and Thermal Protection.
- Adjustable Output Voltage or Fixed at 1.8V, 2.5V, 3.3V.
- Standard 3-Pin Power Packages.

APPLICATIONS

- Post Regulator for Switching Supply.
- Battery Chargers.
- PC Add-On Card.

DESCRIPTION

The AIC1086 is a low dropout three-terminal regulator designed to provide output current up to 1.5A. The device is available in an adjustable version and fixed output voltage of 1.8V, 2.5V, 3.3V. Dropout voltage of maximum of 1.5V is guaranteed at 1.5A output current. The quality of low dropout voltage and fast transient response make this device ideal for low voltage microprocessor applications.

The AIC1086 requires output capacitance of a minimum of 10μF for stability. Built-in output current limiting and thermal limiting provide maximal protection to the AIC1086 against fault conditions.

TYPICAL APPLICATION CIRCUIT

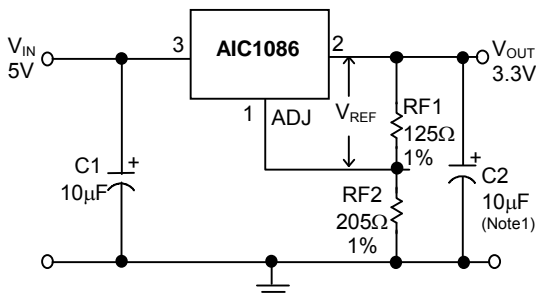

Adjustable Voltage Regulator

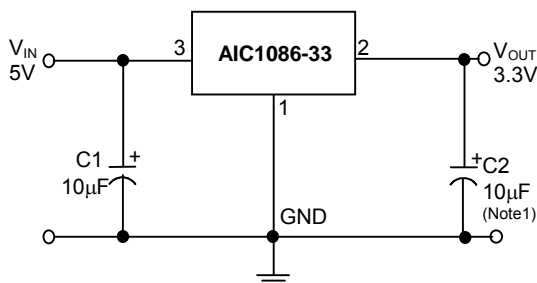

Fixed Voltage Regulator

$$V_{REF} = V_{OUT} - V_{ADJ} = 1.25V \text{ (typ.)}$$

$$V_{OUT} = V_{REF} \times (1 + RF2/RF1) + I_{ADJ} \times RF2$$

$$I_{ADJ} = 55\mu A \text{ (typ.)}$$

- (1) C1 needed if device is far away from filter capacitors.
- (2) C2 required for stability.

ORDERING INFORMATION

AIC1086-XX XX XX

PACKING TYPE
 TR: TAPE & REEL
 TB: TUBE
 BG: BAG (for SOT-223)

PACKAGING TYPE
 E: TO-252
 M: TO-263
 T: TO-220
 Y: SOT-223

G: GREEN PACKAGE

OUTPUT VOLTAGE
 DEFAULT: ADJUSTABLE
 18: 1.8V
 25: 2.5V
 33: 3.3V

Example: AIC1086-33GETR
 → 3.3V version in TO-252 Package & Taping & Reel Packing Type
 AIC1086-33GMTR
 → 3.3V version in TO-263 Green Package & Taping & Reel Packing Type

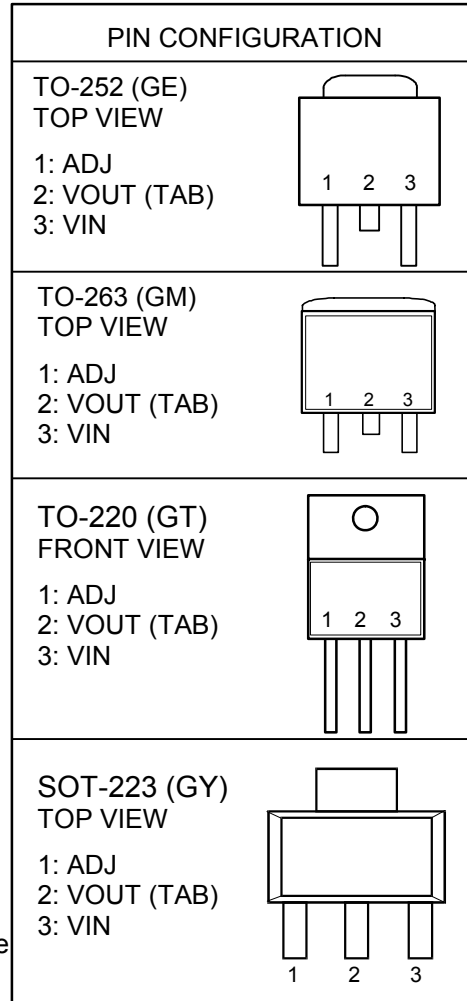

● **SOT-223 Marking**

Part No.	GY
AIC1086	1086G
AIC1086-18GY	AX18G
AIC1086-25GY	AX25G
AIC1086-33GY	AX33G

■ **ABSOLUTE MAXIMUM RATINGS**

VIN pin to ADJ/ GND pin	7V
Operating Temperature Range	-40°C to 85°C
Operating Junction Temperature Range	0°C ~ 125°C
Storage Temperature Range	-65°C ~ 150°C
Maximum Junction Temperature	125°C
Lead Temperature (Soldering, 10 sec)	260°C
Thermal Resistance (Junction to Case)	TO-2203°C /W
	TO-25212.5°C /W
	SOT-22315°C /W
	TO-2633°C /W
Thermal Resistance Junction to Ambient	TO-252100°C/W
(Assume no ambient airflow, no heatsink)	TO-26360°C /W
	SOT-223155°C /W
	TO-22050°C /W

Absolute Maximum Ratings are those values beyond which the life of a device may be impaired.

■ **TEST CIRCUIT**

Refer to TYPICAL APPLICATION CIRCUIT.

■ ELECTRICAL CHARACTERISTICS

($V_{IN}=5V$, $T_J=25^{\circ}C$, $I_O=10mA$, unless otherwise specified) (Note2)

PARAMETER	TEST CONDITIONS	MIN.	TYP.	MAX.	UNIT
Reference Voltage	AIC1086 (ADJ), $T_J=25^{\circ}C$	1.238	1.25	1.262	V
	$0^{\circ}C \leq T_J \leq 125^{\circ}C$	1.225	1.25	1.275	
Output Voltage	AIC1086-18, $V_{IN}=3.3V$	1.78	1.80	1.82	V
	AIC1086-25, $V_{IN}=5V$	2.47	2.50	2.53	
	AIC1086-33, $V_{IN}=5V$	3.26	3.30	3.33	
Line Regulation	$2.75 \leq V_{IN} \leq 7V$, $V_{OUT}=1.25V$ $T_J=25^{\circ}C$		0.015	0.2	%
	$0^{\circ}C \leq T_J \leq 125^{\circ}C$		0.035	0.2	
Load Regulation	$T_J=25^{\circ}C$, $I_O=10mA \sim 1.5A$		0.1	0.3	%
	$0^{\circ}C \leq T_J \leq 125^{\circ}C$		0.2	0.4	
Dropout Voltage	ΔV_{OUT} , $\Delta V_{REF}=1\%$, $I_O=1.5A$ $0^{\circ}C \leq T_J \leq 125^{\circ}C$		1.3	1.5	V
Current Limit	$0^{\circ}C \leq T_J \leq 125^{\circ}C$	1.5	2.0		A
Adjusted Pin Current (I_{ADJ})	$2.75 \leq V_{IN} \leq 7V$, $10mA \leq I_O \leq 1.5A$ $0^{\circ}C \leq T_J \leq 125^{\circ}C$		55	120	μA
Adjusted Pin Current Change (ΔI_{ADJ})	$2.75 \leq V_{IN} \leq 7V$, $10mA \leq I_O \leq 1.5A$ $0^{\circ}C \leq T_J \leq 125^{\circ}C$		0.2	5	μA
Temperature Stability	$I_O=0.5A$, $0^{\circ}C \leq T_J \leq 125^{\circ}C$		0.5		%
GND Current	$2.65 \leq V_{IN} \leq 7V$		10	14	mA
Minimum Load Current	$0^{\circ}C \leq T_J \leq 125^{\circ}C$		5	10	mA
RMS Output Noise (% of V_{OUT})	$10Hz \leq f \leq 10KHz$		0.003		%
Ripple Rejection Ratio	120Hz input ripple, $C_{OUT}=25\mu F$	60	72		dB

Note 1: To avoid output oscillation, aluminum electrolytic output capacitor is recommended and ceramic capacitor is not suggested.

Note 2: Specifications are production tested at $T_A=25^{\circ}C$. Specifications over the $-40^{\circ}C$ to $85^{\circ}C$ operating temperature range are assured by design, characterization and correlation with Statistical Quality Controls (SQC).

Note 3: Regulation is measured at constant junction temperature, using pulse testing with a low ON time.

Note 4: Current limit is measured by pulsing a short time.

Note 5: Dropout voltage is defined as the input to output differential at which the output voltage drops 100mV below the value measured with a 1V differential.

■ TYPICAL PERFORMANCE CHARACTERISTICS

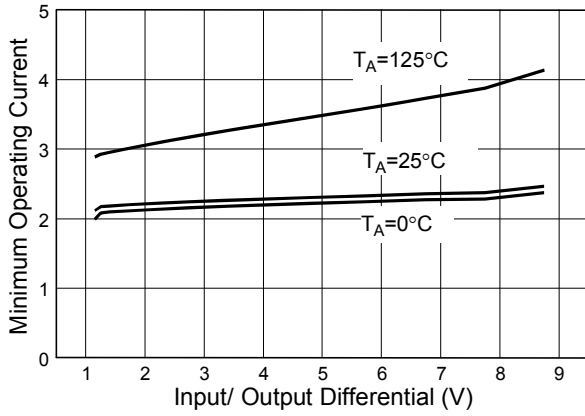

Fig. 1 AIC1086 Min. Load Current (Adjustable Version)

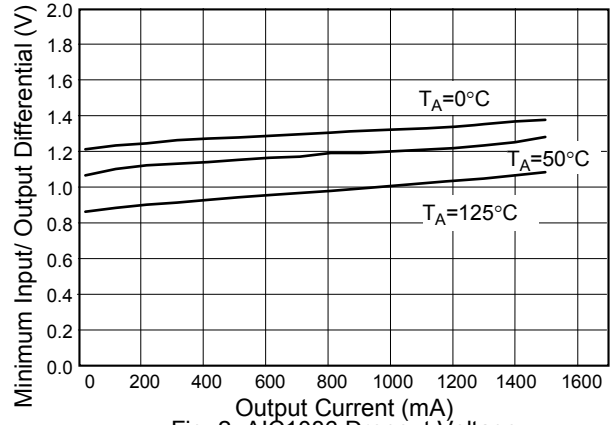

Fig. 2 AIC1086 Dropout Voltage

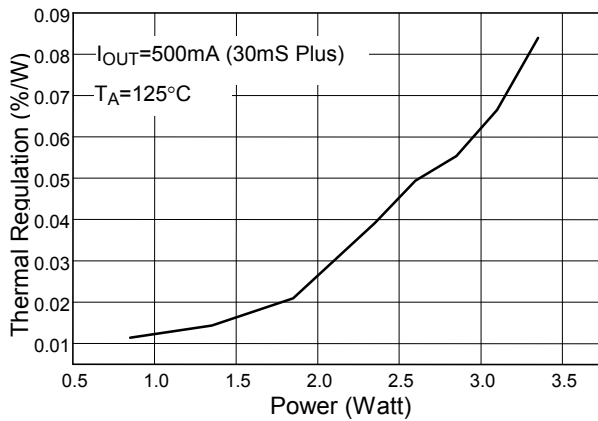

Fig. 3 AIC1086 (ADJ) Power vs. Thermal Regulation

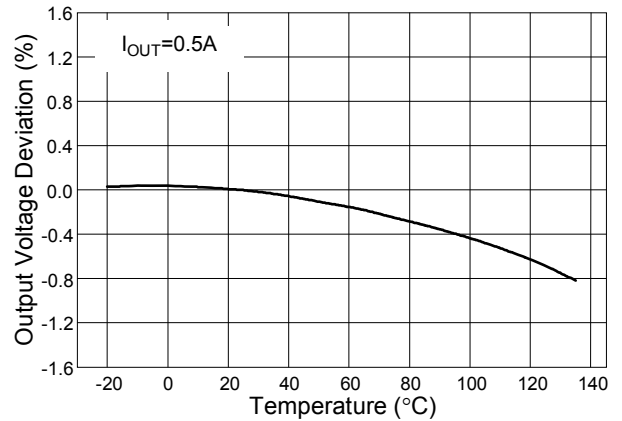

Fig. 4 AIC1086 (ADJ) Temperature Stability

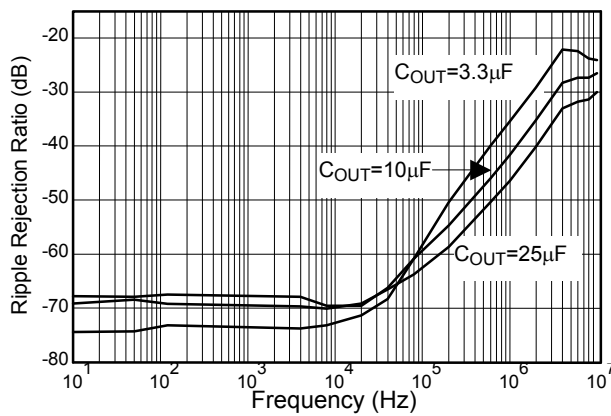

Fig. 5 AIC1086 (ADJ) Ripple Rejection Ratio (dB)

■ **TYPICAL PERFORMANCE CHARACTERISTICS (Continued)**

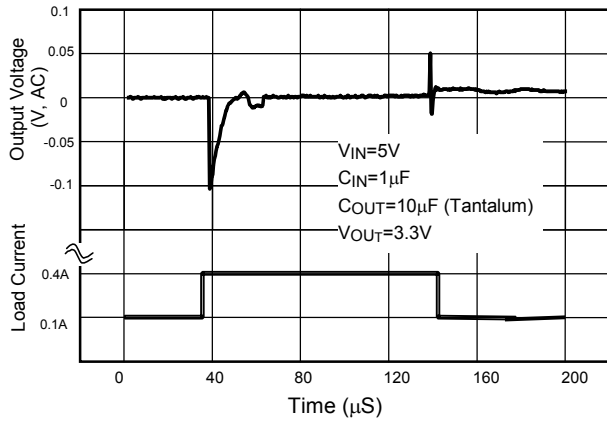

Fig. 6 Load Transient Response

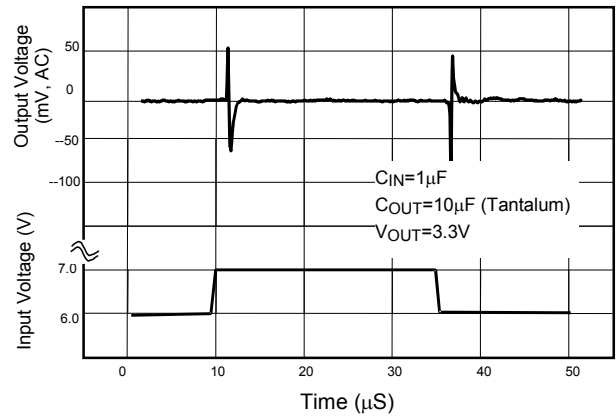
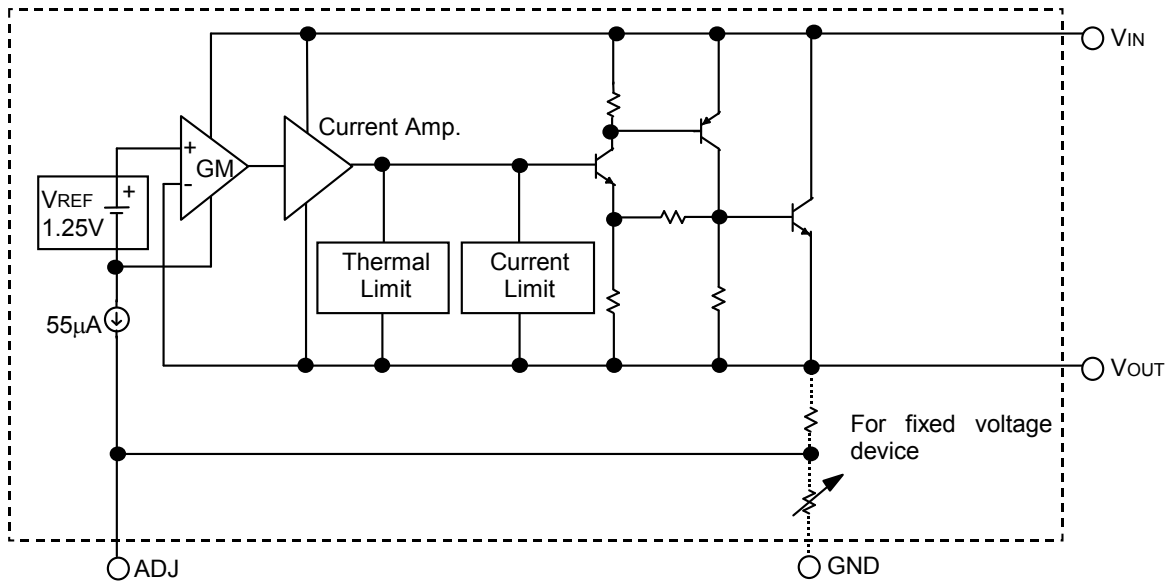

Fig. 7 Line Transient Response

■ **BLOCK DIAGRAM**



■ **PIN DESCRIPTIONS**

- ADJ PIN - Providing $V_{REF}=1.25\text{V}$ (typ.) for adjustable V_{OUT} . $V_{REF}=V_{OUT}-V_{ADJ}$ and $I_{ADJ}=55\mu\text{A}$ (typ.) (GND PIN - Power ground.)
- VOUT PIN - Adjustable output voltage.
- VIN PIN - Power Input.

APPLICATION INFORMATION

INPUT-OUTPUT CAPACITORS

Linear regulators require input and output capacitors to maintain stability. Input capacitor at 10 μ F with a 10 μ F aluminum electrolytic output capacitor is recommended.

POWER DISSIPATION

The AIC1086 obtains thermal-limiting circuitry, which is designed to protect the device against overload condition. For continuous load condition, maximum rating of junction temperature must not be exceeded. It is important to pay more attention in thermal resistance. It includes junction to case, junction to ambient. The maximum power dissipation of AIC1086 depends on the thermal resistance of its case and circuit board, the temperature difference between the die junction and ambient air, and the rate of airflow. The rate of temperature rise is greatly affected by the mounting pad configuration on the PCB, the

board material, and the ambient temperature. When the IC mounting with good thermal conductivity is used, the junction temperature will be low even when large power dissipation applies.

The power dissipation across the device is

$$P = I_{OUT} (V_{IN} - V_{OUT})$$

The maximum power dissipation is:

$$P_{MAX} = \frac{(T_{J-max} - T_A)}{R\theta_{JA}}$$

Where T_{J-max} is the maximum allowable junction temperature (125°C), and T_A is the ambient temperature suitable in application.

As a general rule, the lower temperature is, the better reliability of the device is. So the PCB mounting pad should provide maximum thermal conductivity to maintain low device temperature.

APPLICATION EXAMPLES

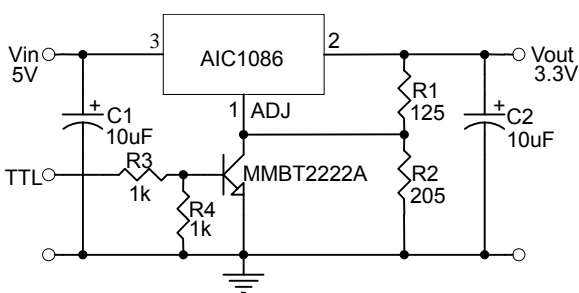
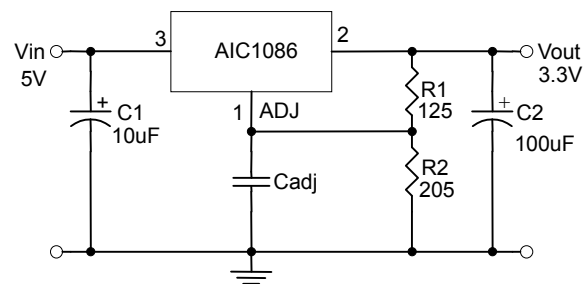

Fig. 8 $V_{OUT}=3.3V$ with Shutdown



* Cadj can improve ripple rejection

Fig. 9 Improving Ripple Rejection

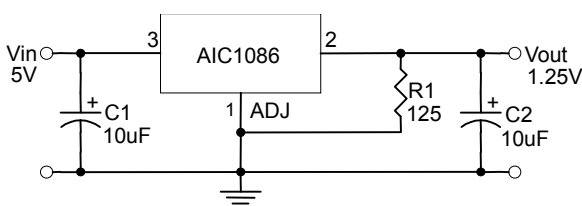

Fig. 10 $V_{OUT}=1.25V$ Application Circuit

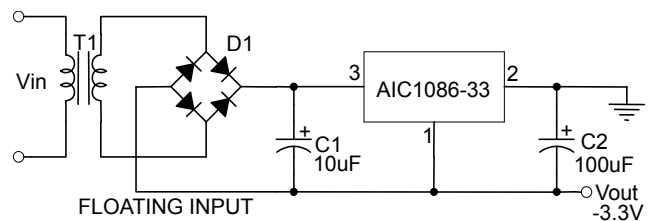
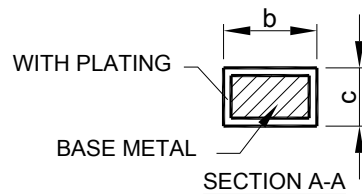
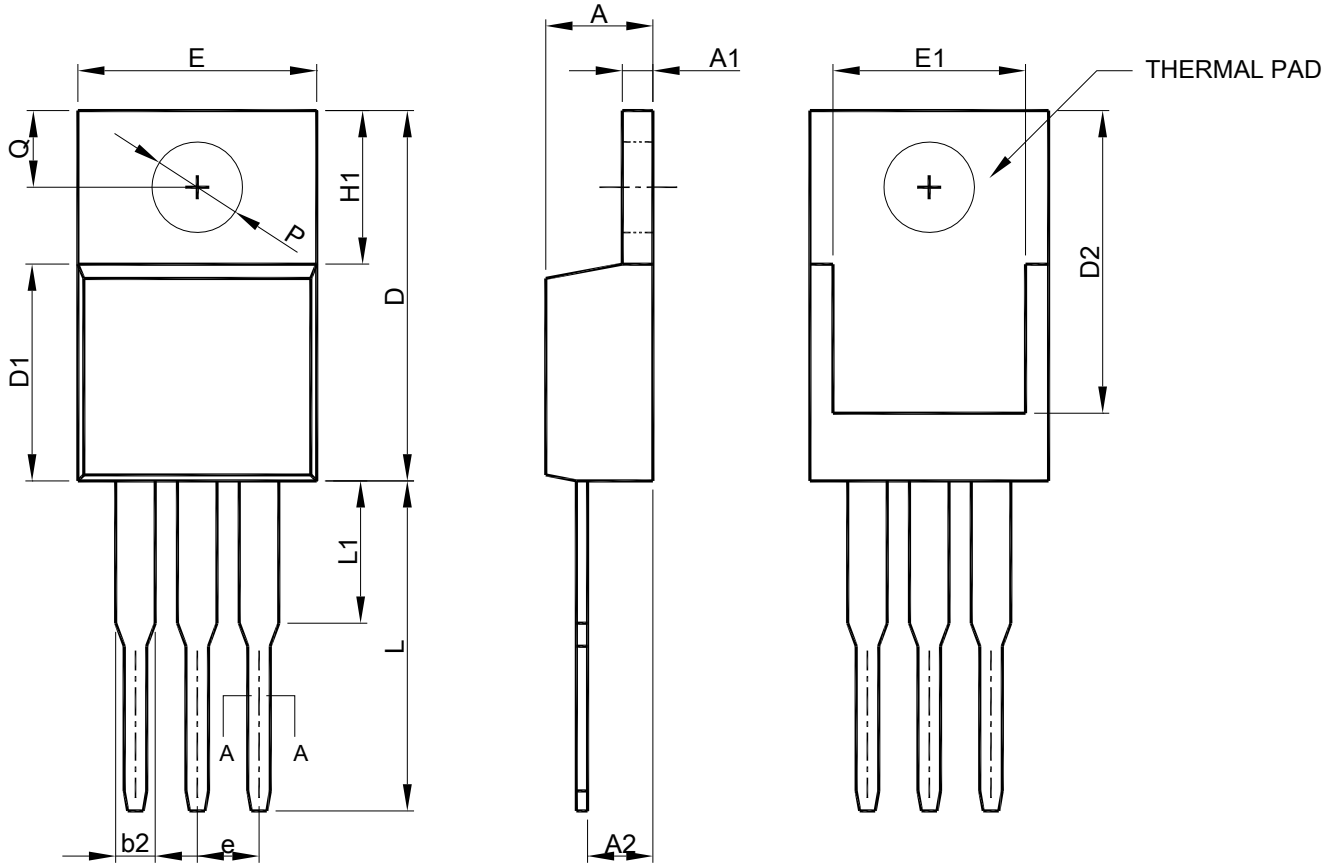

Fig. 11 Low Dropout Negative Supply

PHYSICAL DIMENSIONS

- TO-220 (unit: mm)



SYMBOL	TO-220	
	MILLIMETERS	
	MIN.	MAX.
A	3.56	4.82
A1	0.51	1.39
A2	2.04	2.92
b	0.38	1.01
b2	1.15	1.77
c	0.35	0.61
D	14.23	16.51
D1	8.38	9.02
D2	11.75	12.88
E	9.66	10.66
E1	6.86	8.90
e	2.54 BSC	
H1	5.85	6.85
L	12.70	14.73
L1	--	6.35
P	3.54	4.08
Q	2.54	3.42

- Note: 1. Refer to JEDEC TO-220AB.
 2. Dimension "E" does not include mold flash, protrusions or gate burrs. Mold flash, protrusion or gate burrs shall not exceed 6 mil per side.
 3. Dimension "D1" does not include inter-lead flash or protrusions.
 4. Controlling dimension is millimeter, converted inch dimensions are not necessarily exact.

● TO-252 (unit: mm)

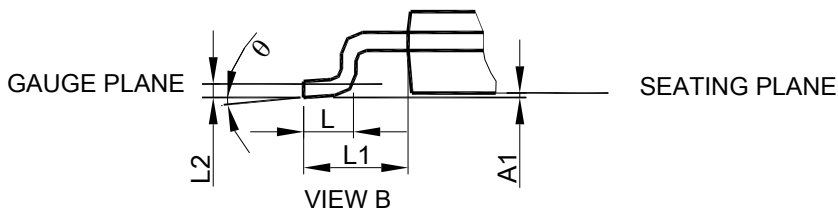
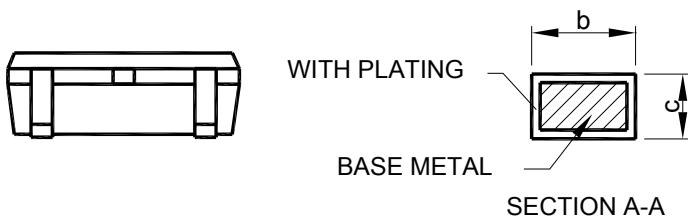
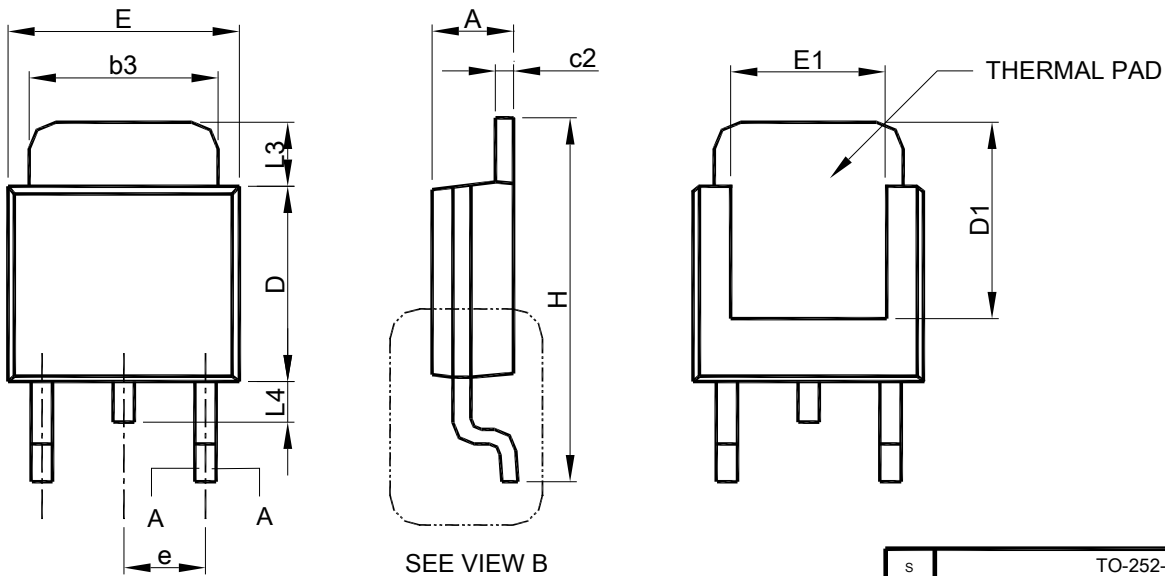

SYMBOL	TO-252-3L	
	MILLIMETERS	
	MIN.	MAX.
A	2.19	2.38
A1	0.00	0.13
b	0.64	0.89
b3	4.95	5.46
c	0.46	0.61
c2	0.46	0.89
D	5.33	6.22
D1	4.60	6.00
E	6.35	6.73
E1	3.90	5.46
e	2.28 BSC	
H	9.40	10.41
L	1.40	1.78
L1	2.67 REF	
L2	0.51 BSC	
L3	0.89	2.03
L4	--	1.02
θ	0°	8°

- Note: 1. Refer to JEDEC TO-252AA and AB.
 2. Dimension "E" does not include mold flash, protrusions or gate burrs. Mold flash, protrusion or gate burrs shall not exceed 6 mil per side .
 3. Dimension "D" does not include inter-lead flash or protrusions.
 4. Controlling dimension is millimeter, converted inch dimensions are not necessarily exact.

● SOT-223(unit: mm)

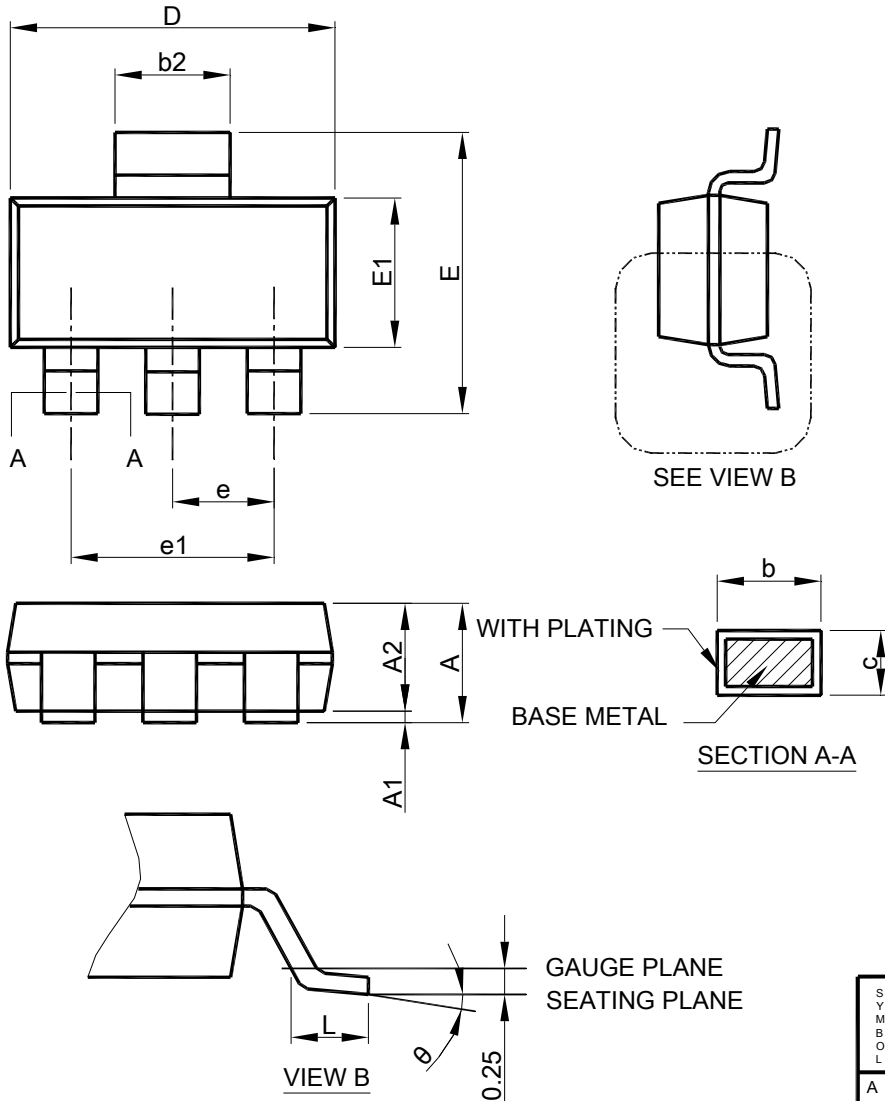

- Note: 1. Refer to JEDEC TO-261AA.
 2. Dimension "D" does not include mold flash, protrusions or gate burrs. Mold flash, protrusion or gate burrs shall not exceed 6 mil per side .
 3. Dimension "E1" does not include inter-lead flash or protrusions.
 4. Controlling dimension is millimeter, converted inch dimensions are not necessarily exact.

SYMBOL	SOT-223	
	MILLIMETERS	
	MIN.	MAX.
A		1.80
A1	0.02	0.10
A2	1.55	1.65
b	0.66	0.84
b2	2.90	3.10
c	0.23	0.33
D	6.30	6.70
E	6.70	7.30
E1	3.30	3.70
e	2.30 BSC	
e1	4.60 BSC	
L	0.90	
θ	0°	8°

● TO-263 (unit: mm)

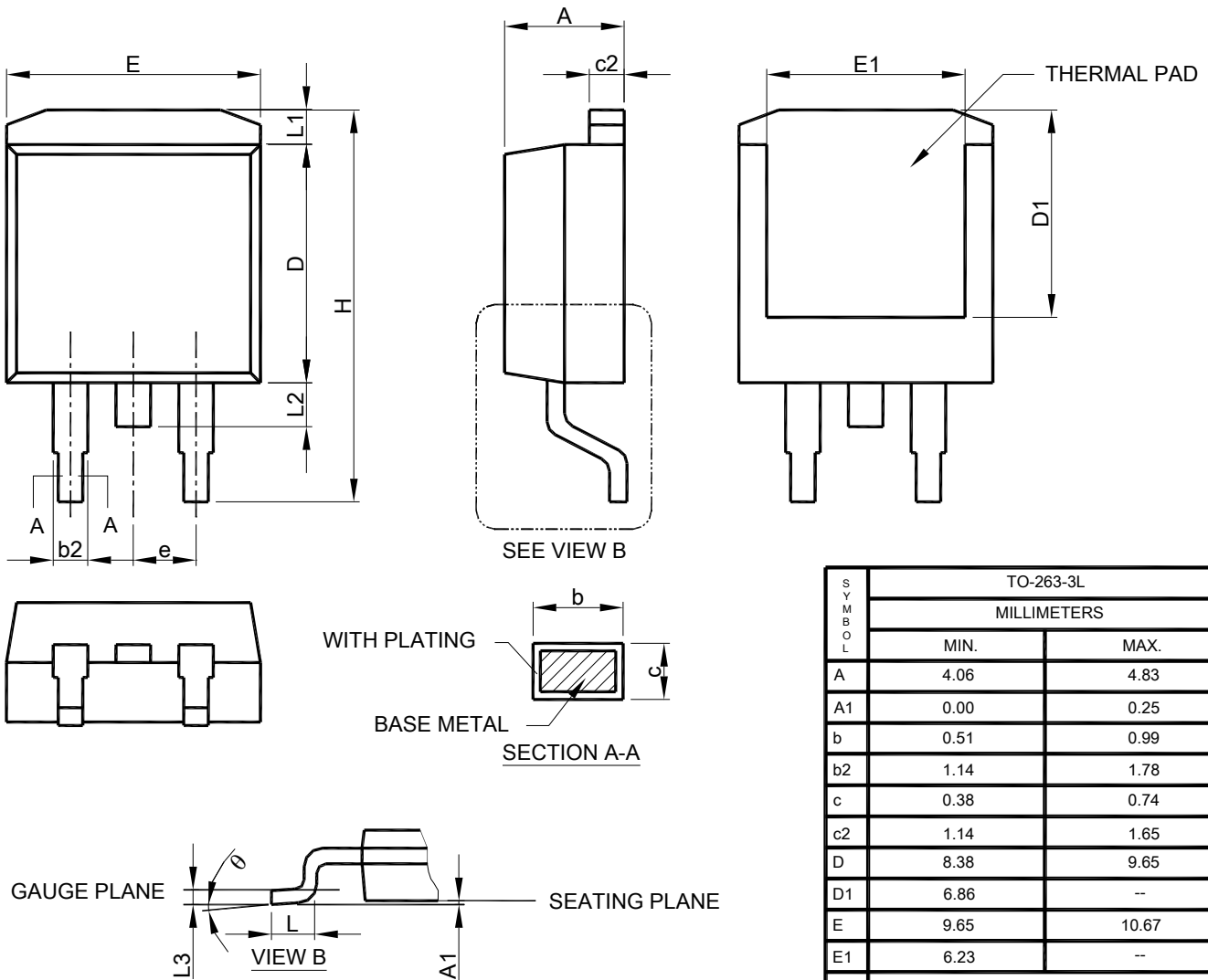

SYMBOL	TO-263-3L	
	MILLIMETERS	
	MIN.	MAX.
A	4.06	4.83
A1	0.00	0.25
b	0.51	0.99
b2	1.14	1.78
c	0.38	0.74
c2	1.14	1.65
D	8.38	9.65
D1	6.86	--
E	9.65	10.67
E1	6.23	--
e	2.54 BSC	
H	14.61	15.88
L	1.78	2.79
L1	--	1.68
L2	--	1.78
L3	0.25 BSC	
theta	0°	8°

- Note:
1. Refer to JEDEC TO-263AB.
 2. Dimension "E" does not include mold flash, protrusions or gate burrs. Mold flash, protrusion or gate burrs shall not exceed 6 mil per side .
 3. Dimension "D" does not include inter-lead flash or protrusions.
 4. Controlling dimension is millimeter, converted inch dimensions are not necessarily exact.

Note:

Information provided by AIC is believed to be accurate and reliable. However, we cannot assume responsibility for use of any circuitry other than circuitry entirely embodied in an AIC product; nor for any infringement of patents or other rights of third parties that may result from its use. We reserve the right to change the circuitry and specifications without notice.

Life Support Policy: AIC does not authorize any AIC product for use in life support devices and/or systems. Life support devices or systems are devices or systems which, (i) are intended for surgical implant into the body or (ii) support or sustain life, and whose failure to perform, when properly used in accordance with instructions for use provided in the labeling, can be reasonably expected to result in a significant injury to the user.