

Schottky Barrier Rectifier

SH55BF - SH56BF

Features

- Metal silicon junction, majority carrier conduction
- High forward surge current capability
- Low forward voltage drop
- High temperature soldering guaranteed: 260°C @ 10s
- Robust guarding for over voltage protection
- RoHS compliant with Halogen-free



Mechanical Data

- Case: SMBF molded plastic
- Molding compound: UL flammability classification rating 94V-0
- Terminals: Matte tin plated leads; solderable per J-STD-002 and JESD22-B102
- Polarity: Color band denotes cathode end

Maximum Ratings (@ T_A = 25°C unless otherwise specified)

Parameter	Symbol	SH55BF	SH56BF	Unit
Peak Repetitive Reverse Voltage	V _{RRM}	50	60	V
RMS Reverse Voltage	V _{RMS}	35	42	V
DC Blocking Voltage	V _{DC}	50	60	V
Average Forward Output Current	I _{F_AV}	5.0		A
Peak Forward Surge Current, 8.3ms Single Half Sine wave	I _{FSM}	150		A

Thermal Characteristics

Parameter	Symbol	SH55BF	SH56BF	Unit
Typical Thermal Resistance ^{**1}	R _{θJA}	65		°C/W
	R _{θJC}	16		
	R _{θJL}	15		
Operating Junction Temperature Range	T _J	-55 ~ +150		°C
Storage Temperature Range	T _{STG}	-55 ~ +150		°C

Note 1: Device mounted on p.c.b. with 10 mm x 20 mm x 0.1 mm copper pad area

Schottky Barrier Rectifier

SH55BF - SH56BF

Electrical Characteristics (@ $T_A = 25^\circ\text{C}$ unless otherwise specified)

Parameter	Symbol	Test Conditions		Typ.	Max.	Unit
Instantaneous Forward Voltage*1	V_F	$I_F = 5.0\text{A}$	@ $T_A = 25^\circ\text{C}$	-	0.65	V
Reverse Current*2	I_R	Rated V_R	@ $T_J = 25^\circ\text{C}$	-	250	μA
			@ $T_J = 100^\circ\text{C}$	-	15	mA

Note¹: Pulse test: 300us pulse width, 1 % duty cycle

Note²: Pulse test: Pulse width 40ms

Schottky Barrier Rectifier

SH55BF - SH56BF

Ratings and Characteristic Curves (@ $T_A = 25^\circ\text{C}$ unless otherwise noted)

Fig.1 Forward Current Derating Curve

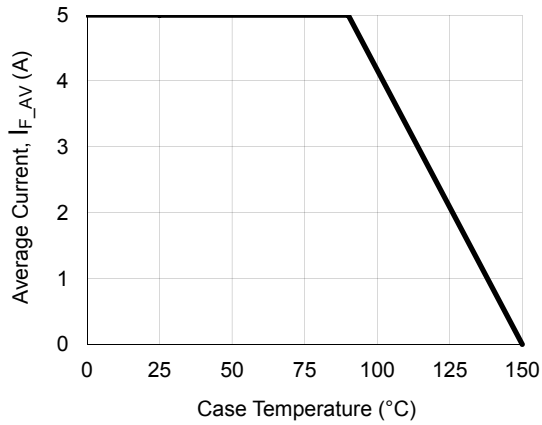

Fig.2 Surge Current Derating Curve

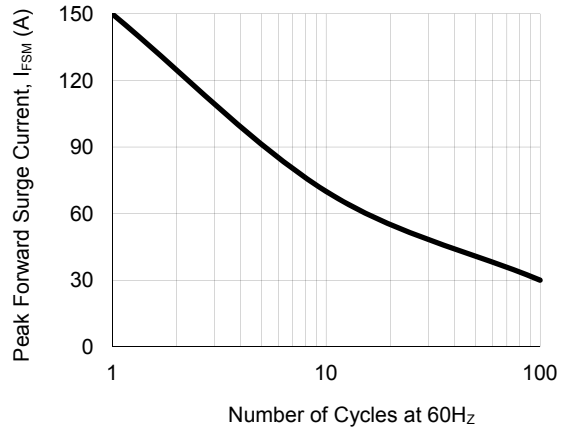

Fig.3 Typical Forward Voltage Characteristics

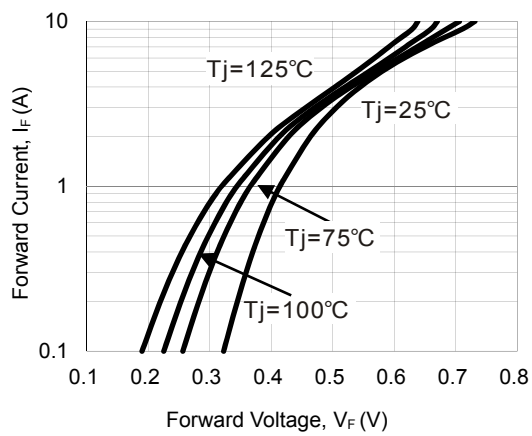
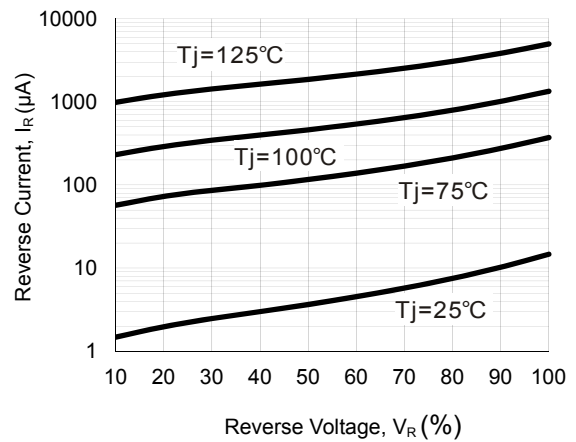

Fig.4 Typical Reverse Characteristics



Schottky Barrier Rectifier

SH55BF - SH56BF

Package Outline Dimensions (Unit: mm)

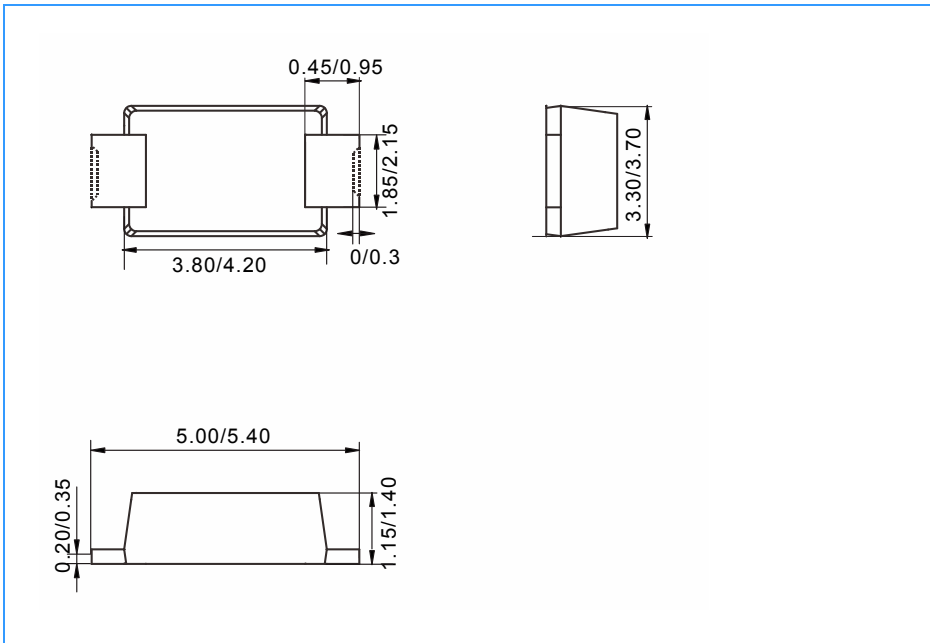

Mounting Pad Layout (Unit: mm)

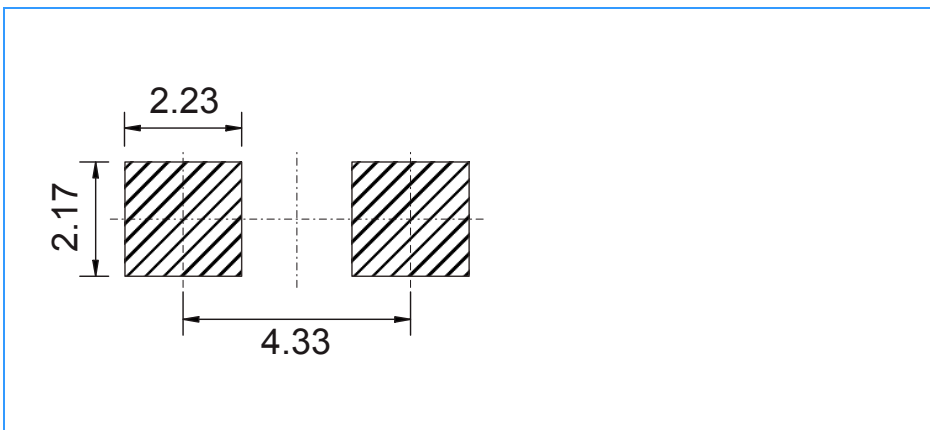

Ordering Information

Part Number	Marking	Package	Shipping Quantity
SH55BF	SH55BF	SMBF	4000 pcs / Tape & Reel
SH56BF	SH56BF	SMBF	4000 pcs / Tape & Reel