

TRANSISTOR(PNP)

FEATURES

- Small Surface Mount Package
- High DC Current Gain

MAXIMUM RATINGS (T_a=25°C unless otherwise noted)

Symbol	Parameter	Value	Unit
V _{CB0}	Collector-Base Voltage	-50	V
V _{CEO}	Collector-Emitter Voltage	-45	V
V _{EBO}	Emitter-Base Voltage	-5	V
I _C	Collector Current	-100	mA
P _C	Collector Power Dissipation	200	mW
R _{θJA}	Thermal Resistance From Junction To Ambient	625	°C/W
T _j	Junction Temperature	150	°C
T _{stg}	Storage Temperature	-55~+150	°C

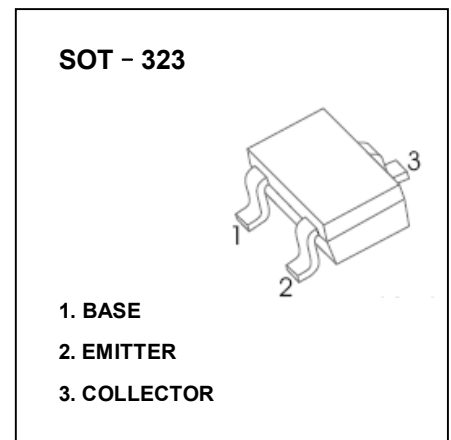

ELECTRICAL CHARACTERISTICS (T_a=25°C unless otherwise specified)

Parameter	Symbol	Test conditions	Min	Typ	Max	Unit
Collector-base breakdown voltage	V _{(BR)CBO}	I _C =-100μA, I _E =0	-50			V
Collector-emitter breakdown voltage	V _{(BR)CEO}	I _C =-100μA, I _B =0	-45			V
Emitter-base breakdown voltage	V _{(BR)EBO}	I _E =-100μA, I _C =0	-5			V
Collector cut-off current	I _{CBO}	V _{CB} =-50V, I _E =0			-100	nA
Emitter cut-off current	I _{EBO}	V _{EB} =-5V, I _C =0			-100	nA
DC current gain	h _{FE}	V _{CE} =-5V, I _C =-1mA	200		1000	
Collector-emitter saturation voltage	V _{CE(sat)}	I _C =-100mA, I _B =-10mA			-0.3	V
Base-emitter saturation voltage	V _{BE(sat)}	I _C =-100mA, I _B =-10mA			-1	V
Base-emitter voltage	V _{BE}	V _{CE} =-5V, I _C =-1mA	-0.6		-0.75	V
Transition frequency	f _T	V _{CE} =-5V, I _C =-10mA, f=30MHz	150			MHz
Collector output capacitance	C _{ob}	V _{CB} =-10V, I _E =0, f=1MHz			7	pF

CLASSIFICATION OF h_{FE}

RANK	L	H
RANGE	200 - 450	450 - 1000
MARKING	M6	