

P0465CTF/P0465CTFS

N-Channel Enhancement Mode MOSFET

PRODUCT SUMMARY

$V_{(BR)DSS}$	$R_{DS(ON)}$	I_D
650V	2.7Ω @ $V_{GS} = 10V$	4A

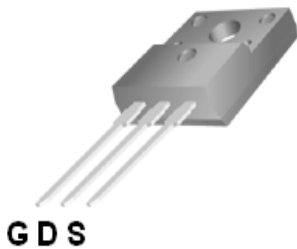

TO-220F
TO-220FS

100% UIS tested

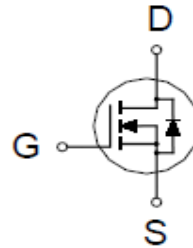

ABSOLUTE MAXIMUM RATINGS ($T_A = 25\text{ °C}$ Unless Otherwise Noted)

PARAMETERS/TEST CONDITIONS		SYMBOL	LIMITS	UNITS
Drain-Source Voltage		V_{DS}	650	V
Gate-Source Voltage		V_{GS}	±30	
Continuous Drain Current ²	$T_C = 25\text{ °C}$	I_D	4	A
	$T_C = 100\text{ °C}$		2.4	
Pulsed Drain Current ^{1, 2}		I_{DM}	15	
Avalanche Current ³		I_{AS}	2	
Avalanche Energy ³		E_{AS}	20	mJ
Power Dissipation	$T_C = 25\text{ °C}$	P_D	24	W
	$T_C = 100\text{ °C}$		9.8	
Operating Junction & Storage Temperature Range		T_j, T_{stg}	-55 to 150	°C

THERMAL RESISTANCE RATINGS

THERMAL RESISTANCE	SYMBOL	TYPICAL	MAXIMUM	UNITS
Junction-to-Case	$R_{\theta JC}$		5.1	°C / W
Junction-to-Ambient	$R_{\theta JA}$		62.5	

¹Pulse width limited by maximum junction temperature.

²Limited only by maximum temperature allowed.

³ $V_{DD} = 50V, L=10mH$. starting $T_j = 25\text{ °C}$.

P0465CTF/P0465CTFS

N-Channel Enhancement Mode MOSFET

ELECTRICAL CHARACTERISTICS (T_J = 25 °C, Unless Otherwise Noted)

PARAMETER	SYMBOL	TEST CONDITIONS	LIMITS			UNITS
			MIN	TYP	MAX	
STATIC						
Drain-Source Breakdown Voltage	V _{(BR)DSS}	V _{GS} = 0V, I _D = 250μA	650			V
Gate Threshold Voltage	V _{GS(th)}	V _{DS} = V _{GS} , I _D = 250μA	2.5	3.2	4.5	
Gate-Body Leakage	I _{GSS}	V _{DS} = 0V, V _{GS} = ±30V			±100	nA
Gate Voltage Drain Current	I _{DSS}	V _{DS} = 650V, V _{GS} = 0V, T _C = 25 °C			10	μA
		V _{DS} = 520V, V _{GS} = 0V, T _C = 100 °C			100	
Drain-Source On-State Resistance ¹	R _{DS(ON)}	V _{GS} = 10V, I _D = 2A		2.2	2.7	Ω
Forward Transconductance ¹	g _{fs}	V _{DS} = 10V, I _D = 2A		2.6		S
DYNAMIC						
Input Capacitance	C _{iss}	V _{GS} = 0V, V _{DS} = 25V, f = 1MHz		521		pF
Output Capacitance	C _{oss}			59		
Reverse Transfer Capacitance	C _{rss}			12		
Total Gate Charge ²	Q _g	V _{DD} = 520V, I _D = 4A, V _{GS} = 10V		14		nC
Gate-Source Charge ²	Q _{gs}			3.5		
Gate-Drain Charge ²	Q _{gd}			6		
Turn-On Delay Time ²	t _{d(on)}	V _{DD} = 325V, I _D = 4A, R _G = 25Ω		28		nS
Rise Time ²	t _r			60		
Turn-Off Delay Time ²	t _{d(off)}			91		
Fall Time ²	t _f			75		
SOURCE-DRAIN DIODE RATINGS AND CHARACTERISTICS (T_J = 25 °C)						
Continuous Current ³	I _S				4	A
Forward Voltage ¹	V _{SD}	I _F = 4A, V _{GS} = 0V			1	V
Reverse Recovery Time	t _{rr}	I _F = 4A, dI _F /dt = 100A/μs		374		nS
Reverse Recovery Charge	Q _{rr}				3.1	

¹Pulse test : Pulse Width ≤ 300 μsec, Duty Cycle ≤ 2%.

²Independent of operating temperature.

³Pulse width limited by maximum junction temperature.

P0465CTF/P0465CTFS

N-Channel Enhancement Mode MOSFET

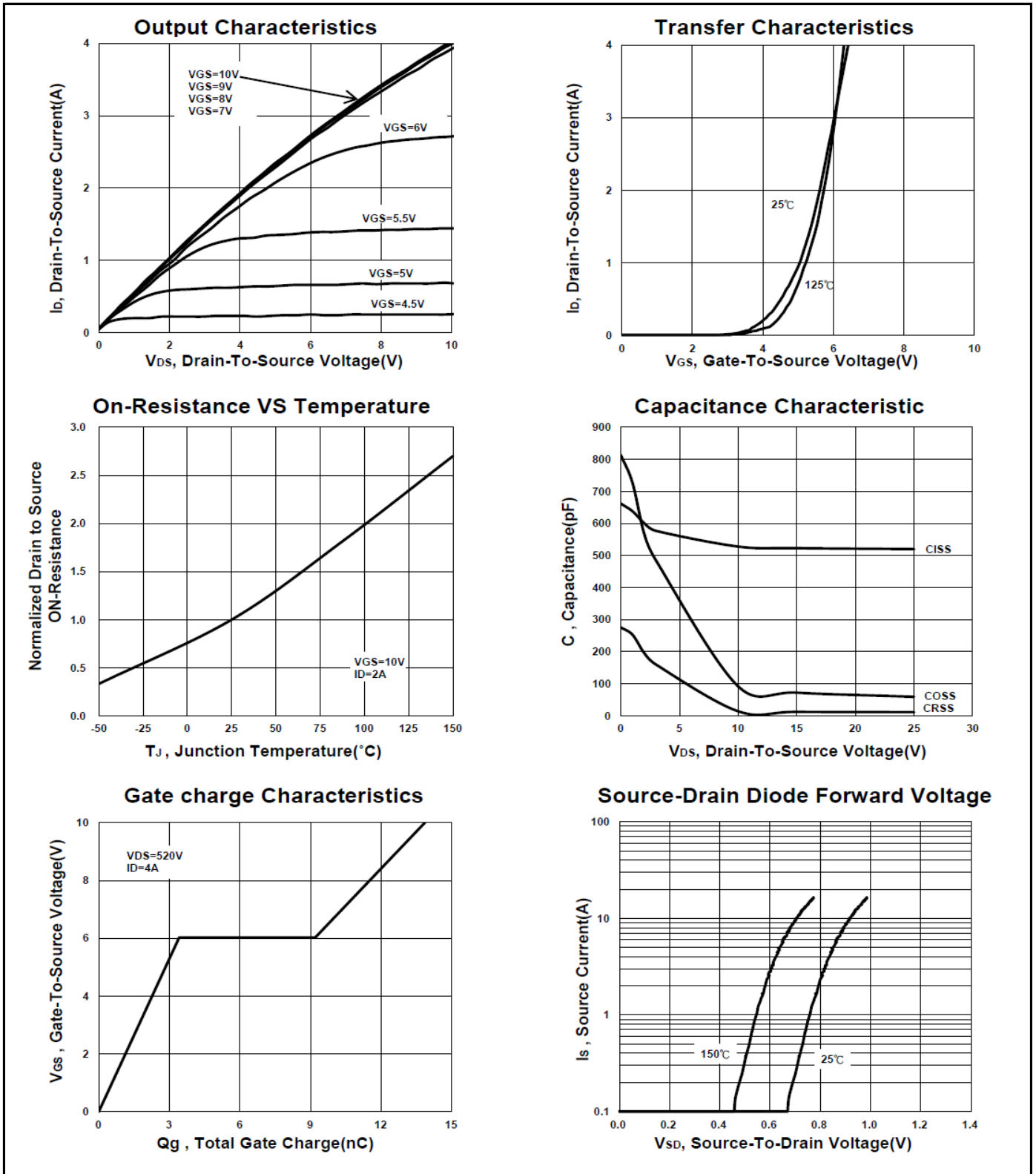

P0465CTF/P0465CTFS

N-Channel Enhancement Mode MOSFET

Safe Operating Area

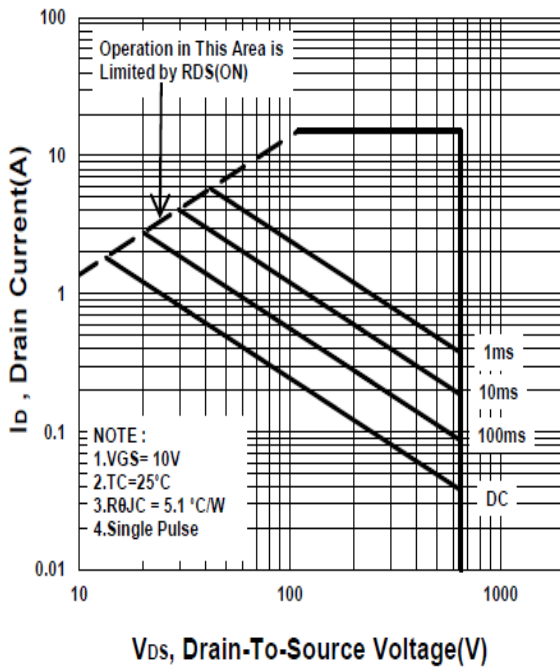

Single Pulse Maximum Power Dissipation

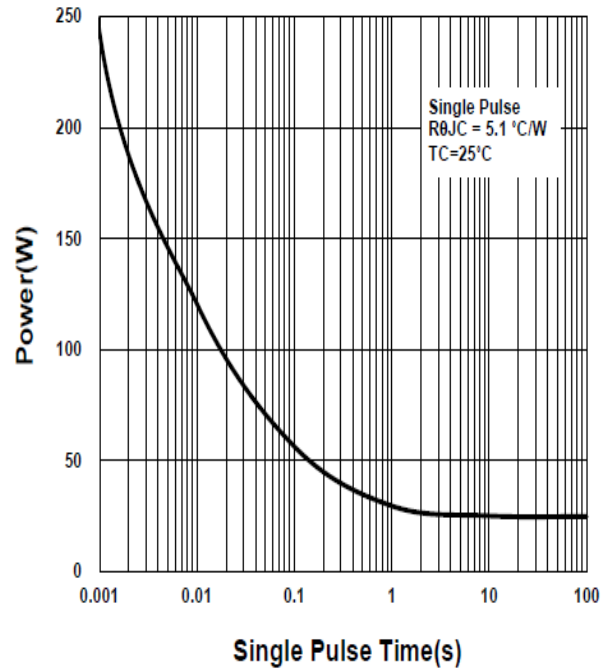

Transient Thermal Response Curve

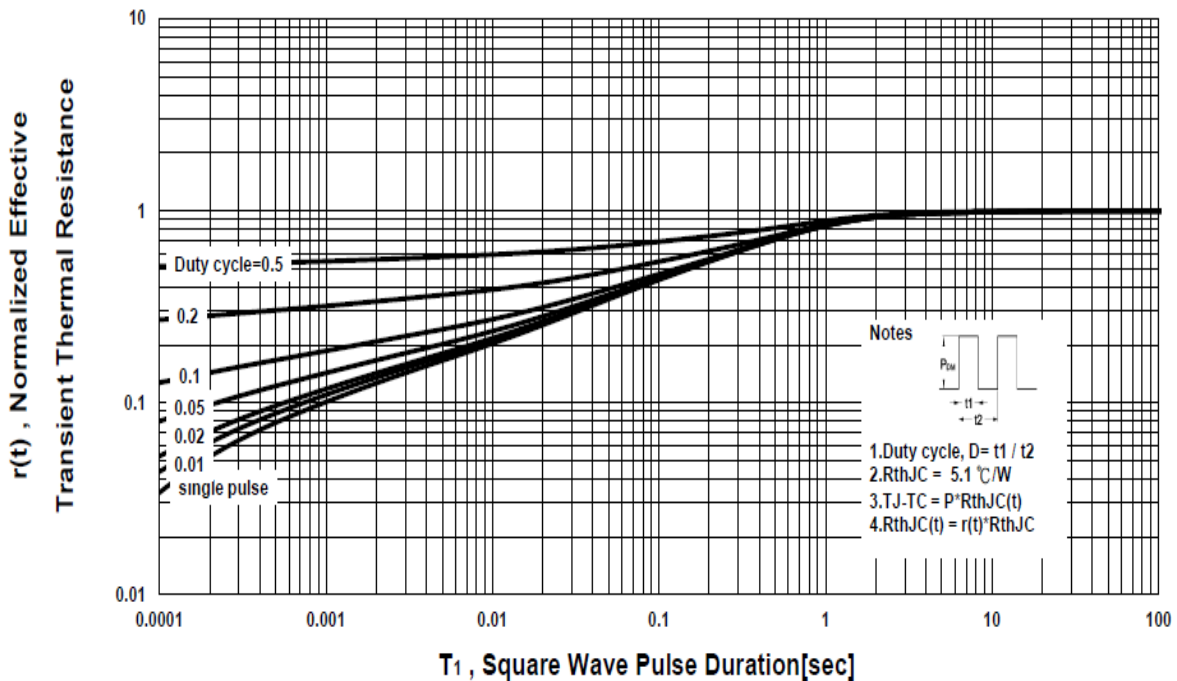

P0465CTF/P0465CTFS

N-Channel Enhancement Mode MOSFET

Package Dimension

TO-220F (3-Lead) MECHANICAL DATA

Dimension	mm			Dimension	mm		
	Min.	Typ.	Max.		Min.	Typ.	Max.
A	4.4		4.93	e	2.34		2.74
A1	2.34		3.1	F	27.2		30.6
B	18.8		20	G	7.7		9.39
b	0.65		1	H	6.18		6.82
b1	0.93		1.6	L	12.7		14.2
b2	0.95		1.6	L1	2.88		3.7
c	0.4		1	P	2.98		3.7
D	13.5		16.4	Q	2.3		2.96
D1	6.48		6.95	q	3.1		3.8
E	9.8		10.4				

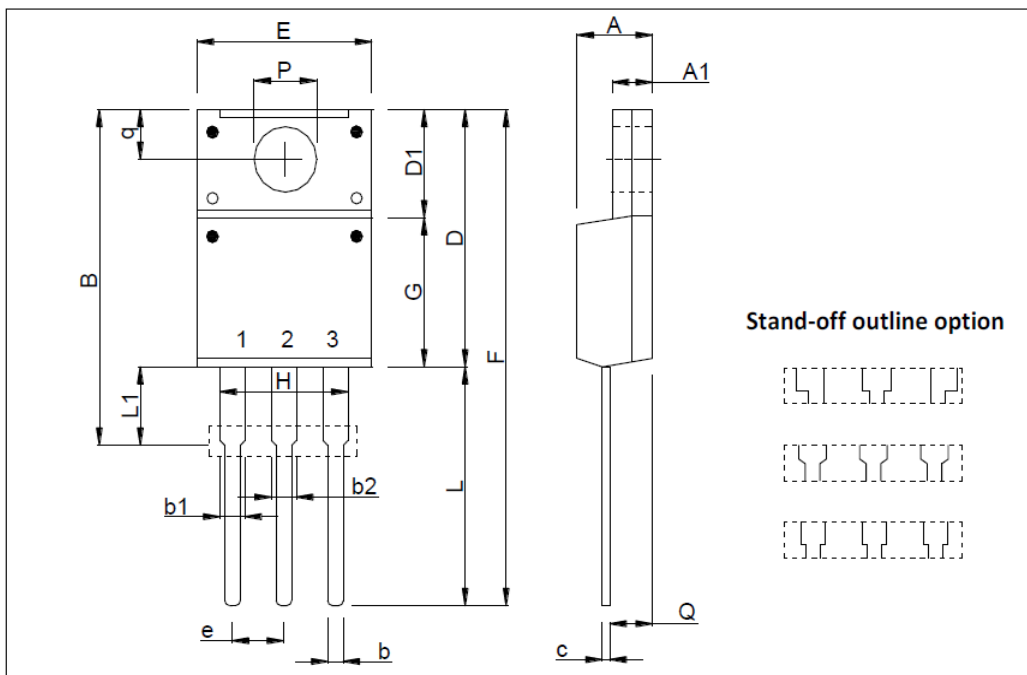

*因各家封装模具不同而外观略有所差异，不影响电性及Layout。

P0465CTF/P0465CTFS

N-Channel Enhancement Mode MOSFET

Package Dimension

TO-220FS (3-Lead) MECHANICAL DATA

Dimension	mm			Dimension	mm		
	Min.	Typ.	Max.		Min.	Typ.	Max.
A	4.2	4.7	4.93	e	2.05	2.54	3.05
A1	2.34	2.745	3.15	F	28.00		30.3
B	16.82		20.3	G	8.2	8.87	9.57
b	0.5	0.775	1.05	L	12.37		14.3
b1	0.8	1.15	1.5	L1	1.4	2.3	2.5
c	0.4	0.7	1.0	P	2.98	3.24	3.5
D	14.80		16.3	Q	2.1	2.6	2.96
D1	5.5		7.5	q	2.7	3.25	3.8
E	9.7	10.16	10.36				

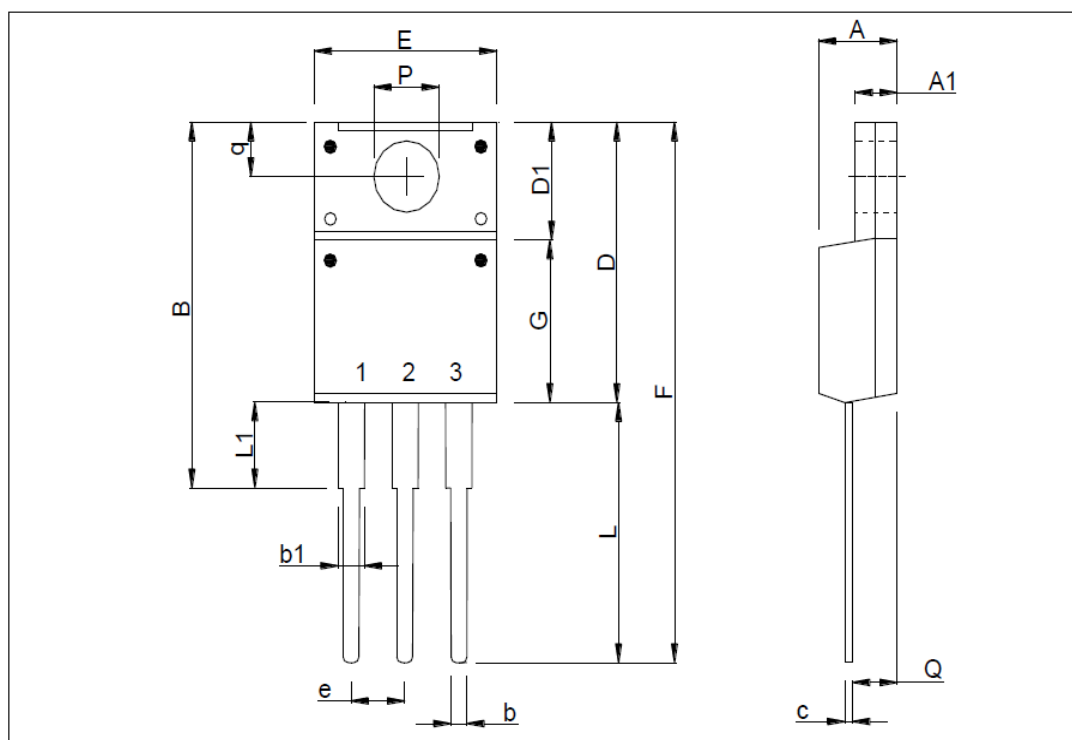

P0465CTF/P0465CTFS

N-Channel Enhancement Mode MOSFET

A. Marking Information

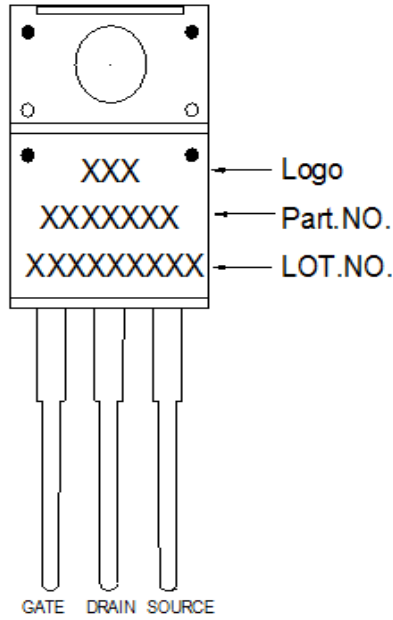

B. Tape & Reel Information: 50pcs/Tube (2000pcs/Box)

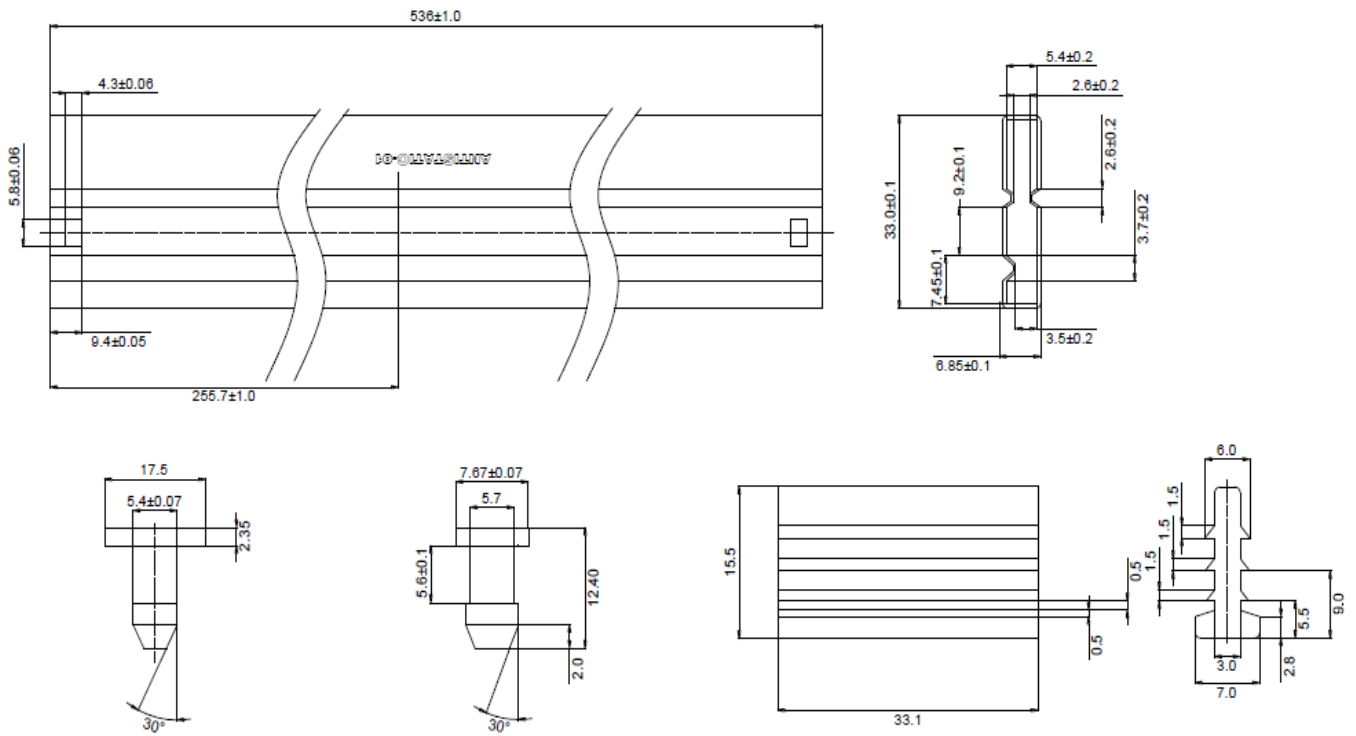

P0465CTF/P0465CTFS

N-Channel Enhancement Mode MOSFET

C. Lot.No. & Date Code rule

1.LOT.NO.

M N 15M21 03

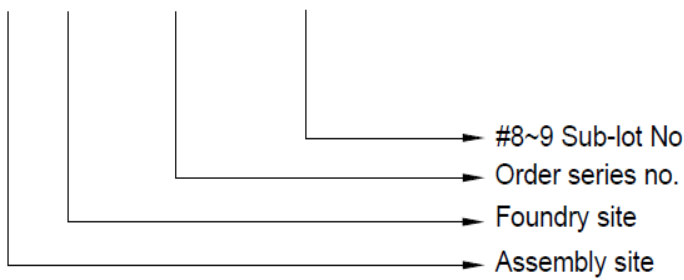

2.Date Code

D Y M X XXX

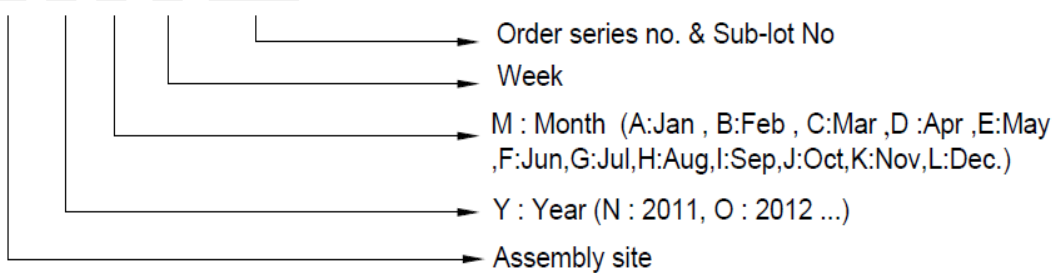

3.Date Code (for Small package)

XX Y WW

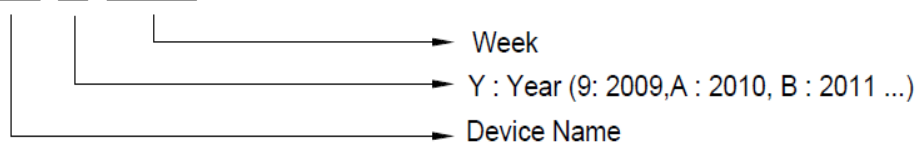



P0465CTF/P0465CTFS

N-Channel Enhancement Mode MOSFET

D.Label rule

标签内容(Label content)



1	Label Size	30 * 90 mm
2	Font style	Times New Roman or Arial (或可区分英文”0”和数字”0”，”G和”Q”的字型即可)
3	Great Power	Height: 4 mm
4	Package	Height: 2 mm
5	Date	Height: 2 mm Shipping date: YYYY/MM/DD, ex. 2008/09/12
6	Device	Height: 3 mm (Max: 16 Digit)
7	Lot	Height: 3 mm (Max: 9 Digit) Sub lot
8	D/C	Height: 3 mm (Max: 7 Digit)
9	QTY	Height: 3 mm (Max: 6 Digit) Thousand mark is no needed
10	Pb Free label	 Diameter: 1 cm bottom color: Green Font color: Black Font style: Arial
11	Halogen Free label	 Diameter: 1 cm bottom color: Green Font color: Black Font style: Arial
12	Scan info	Device / Lot / D/C / QTY , Insert “ / “ between every parts. for example: P3055LDG/G12345601/GGG2301/2000 DPI (Dots per inch): Over 300 dpi Code : Code 128 Height: 6 mm at least