



89024 2400 BPS INTELLIGENT MODEM CHIP SET

- For Public Switched Telephone Network and Unconditioned Leased Line Applications
 - V.22 bis, V.22 A/B, V.21, Bell 212A, and Bell 103 Compatible
 - AT Command Set
 - Automatically Adapts to Remote Modem Type with Recognition of Data Rates
 - DTMF and Pulse Dialing
 - On-Chip Hybrid and Billing Delay Timer
 - On-Chip Serial Port and Handshake Signals for RS-232/V.24 Interface
 - Telephone Line Audio Monitor Output
 - Analog/Digital Loopback Diagnostics
 - Serial Interface to External NVRAM
 - Easily Customized Command Set and Features
 - Two Chip Intelligent Modem Solution with Minimal External Components
 - Output Level Programmable over 16 dB Range
 - Dial and Re-dial Capability
 - Full Set of Control Signals for DAA Interface
 - Local, External, or Slave Timing Options in Synchronous Mode
 - Adaptive Equalization
 - Capable of Detecting Dial, Busy, Ringback and Modem Answer Tones of Most International Networks
 - Auxiliary Relay Control Output
- Packaging:
- For Packages
QN89026 SV231 68-Pin PLCC
QP89027 28-Pin PDIP
Order Kit #89024MV SZ492
 - For Packages
QN89026 SV231 68-Pin PLCC
QN89027 28-Pin PLCC
Order Kit #89024MV SZ493

1

(See Packaging Specification, Order Number 240800-001)

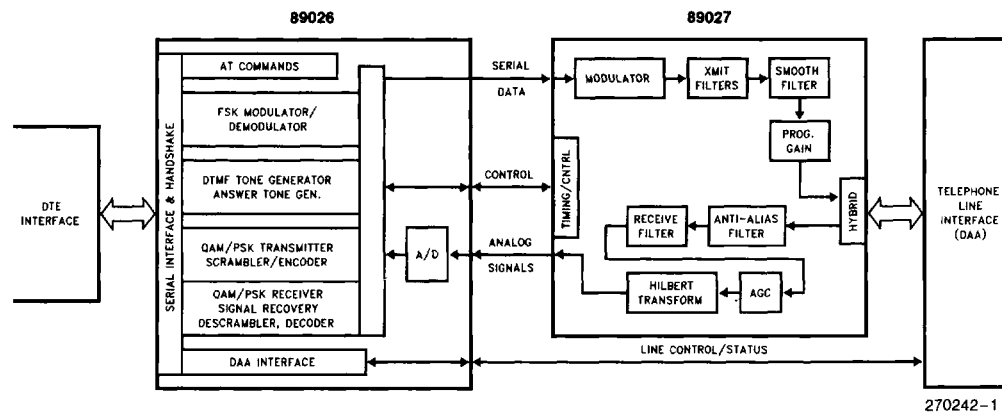

Figure 1. 89024 System Block Diagram

This product is not licensed by Hayes Microcomputer Products, Inc. ("Hayes"). Specific applications of this product may be determined by Hayes to require a license. Intel Corporation does not assume any liability or provide patent indemnification based on such determination.

GENERAL DESCRIPTION

The Intel 89024 chip set is a highly integrated, high performance, intelligent modem, providing a complete system in two chips. The system is compatible with the following CCITT and Bell standards:

- CCITT V.22 bis
 - 2400 bps sync and async
 - 1200 bps sync and async (fall-back)
- CCITT V.22 A & B
 - 1200 bps sync and async
- CCITT V.21
 - 0 to 300 bps anisochronous
- BELL 212A
 - 1200 bps sync and async
 - 300 bps fall-back mode
- BELL 103
 - 0 to 300 bps anisochronous

The 89024 system consists of a 16 bit application specific processor (89026) and an analog front end device (89027). The 89026 processor performs all "Digital Signal Processing" algorithm execution for processing the modem signals, as well as providing all modem control functions typically performed by an external processor. The analog front end provides for 2 wire and 4 wire telephone line interface, D/A conversion, and most of the complex filtering functions required in QAM/PSK/FSK modems. Refer to Figure 1 for a simplified block diagram of the system.

In stand-alone modem applications, the 89024 chip set along with a Data Access Arrangement (DAA), a serial NVRAM, and RS-232 driver/receivers, represent the circuitry required for implementing an auto-dial, auto-answer, 300 to 2400 bps, full duplex intelligent modem.

A complete set of industry standard AT commands is provided for modem configuration and user interface. Virtually all PC software written for the AT command set can also be used with this chip set. Alternatively, in applications where user proprietary modem control commands and features are desired, the user can replace the 89024 internal command module with custom proprietary software resident in the 89026 microcontroller's on-chip ROM or an external memory device.

The 89024 supports two versions of firmware. These are internal, which is asynchronous only and external, which is asynchronous and synchronous. Any differences in operation are highlighted with footnotes.

The 89024 has a set of default features. Upon power up, the modem configuration will be in accordance with these default options, unless a different configuration has been saved in the external NVRAM with the &W command.

The 89024 modem has built in auto-dialing and auto-answering capabilities. It can be configured to the proper line signaling mode (Tone or Pulse), and to the type (CCITT or Bell) and speed of the calling or answering modem. It can also detect and identify call set-up signals of telephone networks, allowing unattended data call operation.

A full set of diagnostic loop-test features compatible with CCITT V.54 is supported. The chip set also provides a line signal for audio monitoring of call progress, a comprehensive set of DAA control lines for a simple interface to the telephone network, and a full complement of TTL level RS-232/ V.24 handshake signals.

PACKAGING

The 89027 is available in PLCC and standard plastic DIP packages. The 89026 is available in a PLCC package.

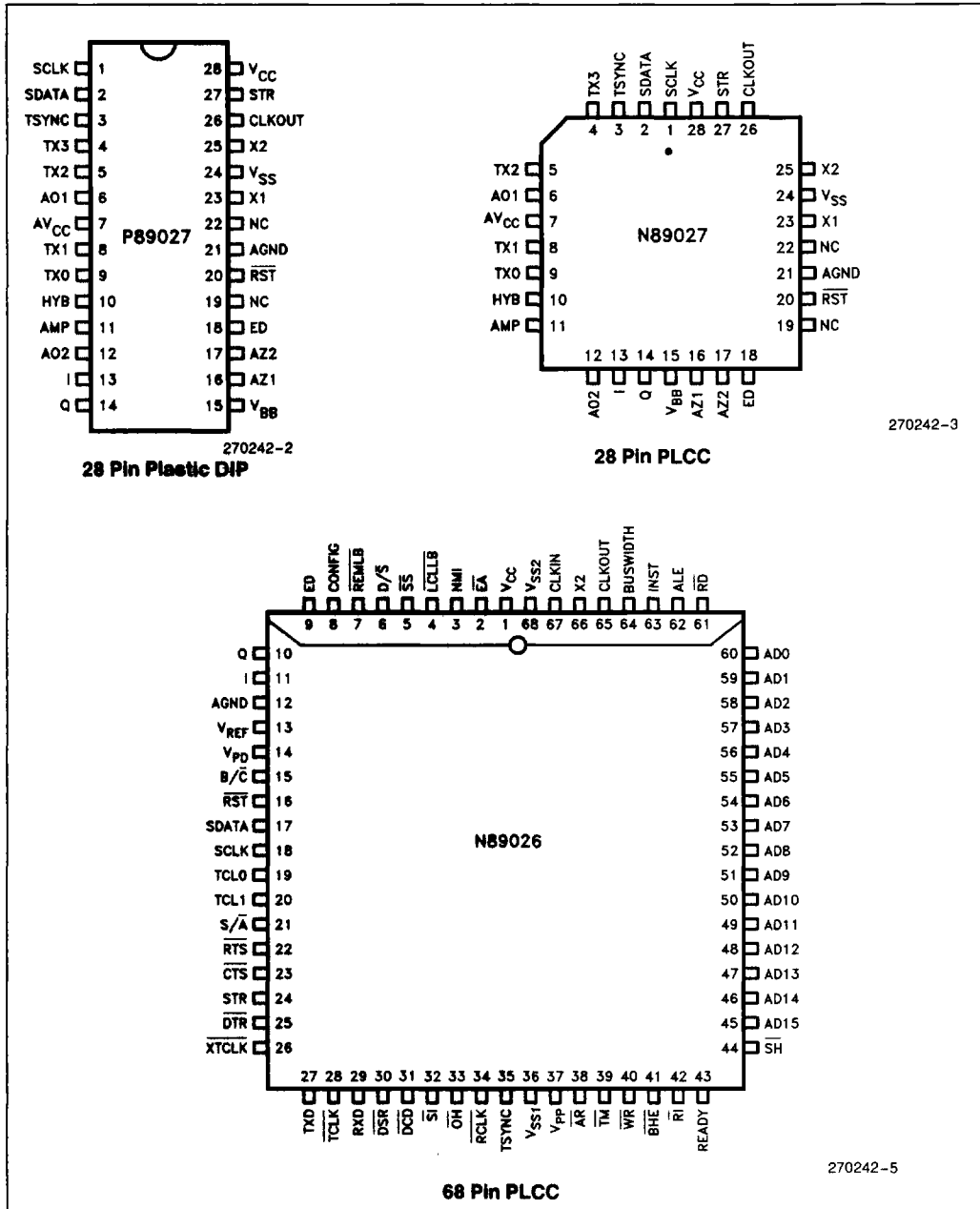
Figure 2. Device Packages

CALL ESTABLISHMENT, TERMINATION AND RETRAIN

The 89024 modem system incorporates all protocols and functions required for automatic or manual call establishment. The modem system also incorporates all protocols and functions required for progress and termination of a data call.

The modem chip-set has a built-in auto-dialer, both DTMF and Pulse type. The modem can detect the dial, busy, and ringback signals at remote end, and will provide call progress messages to the user. The modem is capable of re-dialing the last number dialed, by one command.

The modem when configured for auto-answer, will answer an incoming call, remain silent for the two second billing delay interval, before transmitting the answer tones. Afterwards modem to modem identification and handshaking will proceed at a speed and operating mode acceptable to both ends of the link.

The data call can also be setup by manual dialing with the modems set to data mode, or by voice to data transfer by means of mechanical switch (exclusion key), using the \overline{SH} pin. Once set to data mode, the modem handshaking will proceed before the modems will be ready to accept and exchange data.

During data transmission, if one of the modems finds that the received data is likely to have a high bit error rate (indicated by a large mean square error in the adaptive equalizer), it initiates a retrain sequence. This automatic retrain feature is only available at 2400 bps, and is compatible with CCITT V.22 bis recommendations.

Disconnection of the data call can be initiated by the DTE at the local end or by the remote DTE, (if the modem is configured to accept it). Whether \overline{DTR} will initiate a disconnect, depends on the last &D command. Receiving a long space from a remote modem will initiate a disconnect only after a Y1 command. The optional disconnect requests originated by the remote modem, are of two types, (1) disconnect when receiving long-space, and (2) disconnect

when received carrier is dropped. The modem chip-set can also be configured to transmit 'long-space' just before disconnection, in each of the aforementioned cases.

Because the CCITT and Bell modem connection protocols do not provide recognition of remote modem type (i.e. V.22 bis to 212A), the Intel chip-set provides the additional capability of identifying the remote modem type. This feature is beneficial during the migration phase of the technology from the 1200 bps to 2400 bps. In North America, where the installed base of 1200 bps modems is mostly made-up of 212A type, this feature allows a "Data Base Service Provider" to easily upgrade the existing 212A modems to 2400 bps V.22 bis standard, transparently, to 212A users. Similarly, a user with a 89024 based modem system can automatically call data bases with either 212A or V.22 bis modems, without concern over the difference. This feature's benefits are realized in smooth upgrading of data links, with minimum cost and reduced disruption in services. Refer to Table 1 for a detailed description of remote modem compatibility.

SOFTWARE CONFIGURATION COMMANDS

This section lists the 89024 commands and registers that may be used while configuring the modem. Commands instruct the modem to perform an action, the value in the associated registers determine how the commands are performed, and the result codes returned by the modem tell the user about the execution of the commands.

The commands may be entered in a string, with or without spaces in between. Any spaces within or between commands will be ignored by the modem. During the entry of any command, the 'backspace' key (CNTRL H) can be used to correct any error. Upper case or lower case characters can be used in the commands. Commands described in the following paragraphs refer to asynchronous terminals using ASCII codes.

Table 1. Remote Modem Compatibility

Originating 89024 Modem		Answering Modem				
		Bell 300	Bell 1200	CCITT 300	CCITT 1200	CCITT 2400
Bell	300	300	300	—	300*	300*
	1200	1200*	1200	—	1200	1200
CCITT	300	—	—	300	—	—
	1200	1200*	1200	—	1200	1200
	2400	1200*	1200	—	1200	2400

Answering 89024 Modem		Originating Modem				
		Bell 300	Bell 1200	CCITT 300	CCITT 1200	CCITT 2400
Bell	300	300	1200	—	1200	1200
	1200	300	1200	—	1200	1200
CCITT	300	—	—	300	—	—
	1200	300*	1200	—	1200	1200
	2400	300*	1200	—	1200	2400

* These connection data rates are obtained when connecting 89024 based modems end to end. The same results may not be obtained when a 89024 based modem is connected to other modems.

Command Set

AT	Attention code.
A	Go off-hook in answer mode
A/	Repeat previous command string
Bn ⁽¹⁾	BELL/CCITT Protocol Compatibility at 1200 bps
Ds	The dialing commands (0-9 A B C D * # P R T S W , ; @)
En	Echo command (En)
Hn	Switch-Hook Control If &J1 option is selected, H1 will also switch the auxiliary relay
In	Request Product Code and Checksum
Ln	Speaker Volume
Mn	Monitor On/Off
O	On-Line
Qn	Result Codes
Sn=x	Write S Register
Sn?	Read S Register
Vn	Enable Short-Form Result Codes
Xn	Enable Extended Result Code
Yn	Enable Long Space Disconnect
Z	Fetch Configuration Profile
+++	The Default Escape Code

& Command Set

&C	DCD Options
&D	DTR Options
&F	Fetch Factory Configuration Profile
&G	Guard Tone
&J	Telephone Jack Selection
&L	Leased/Dial-up Line Selection
&M ⁽¹⁾	Async/Sync Mode Selection
&P	Make/Break Pulse Ratio
&R	RTS/CTS Options
&S	DSR Options
&T	Test Commands
&W	Write Configuration to Non Volatile Memory
&X ⁽¹⁾	Sync Clock Source
&Z	Store Telephone Number

NOTE:

1. Available in external code only.

1

CONFIGURATION REGISTERS

The modem stores all the configuration information in a set of registers. Some registers are dedicated to special command and function, and others are bit-mapped, with different commands sharing the register space to store the command status.

S0*	Ring to Answer
S1	Ring Count. (Read Only)
S2	Escape Code Character
S3	Carriage Return Character
S4	Line Feed Character
S5	Back Space Character
S6	Wait for Dial Tone
S7	Wait for Data Carrier
S8	Pause Time for the Comma Dial Modifier
S9	Carrier Detect Response Time
S10	Lost Carrier to Hang Up Delay
S11**	DTMF Tone Duration
S12	Escape Code Guard Time
S13	Not Used
S14 *	Bit Mapped Option Register
S15	Not Used
S16	Modem Test Options
S17	Not Used
S18 *	Test Timer
S19	Not Used
S20	Not Used
S21 *	Bit Mapped Options Register
S22 *	Bit Mapped Options Register
S23 *	Bit Mapped Options Register
S24	Not Used
S25 *	Delay to DTR (Sync Only)
S26 *	RTS to CTS Delay (Half Dup.)
S27 *	Bit Mapped Options Register

NOTE:

* These S registers can be stored in the NVRAM.

**Available in internal code only.

Dial Modifiers

P	Pulse Dial
R	Originate call in Answer Mode
T	Tone Dial
S	Dial a stored number
W	Wait for dial tone
,	Delay a dial sequence
;	Return to command state
!	Initiate a flash
@	Wait for quiet

Example:

Terminal: AT &Z T 1 (602) 555-1212

Modem: OK

Result: Modem stores T16025551212 in the external NVRAM.

The number can be dialed from asynchronous mode by issuing the following command:

Terminal: AT DS

Modem: T16025551212

or by turning on \overline{DTR} when in Synchronous Mode 2. Up to 33 symbols (dial digits and dial modifiers) may be stored. Spaces and other delimiters are ignored and do not need to be included in the count. If more than 33 symbols are supplied, the dial string will be truncated to 33.

APPLICATIONS OVERVIEW

The block diagram of a stand-alone 300 to 2400 bps Hayes compatible modem is depicted in Figure 3. The DAA section shown in this diagram may be obtained with FCC registration, or implemented using the suggested diagram in Figure 4.

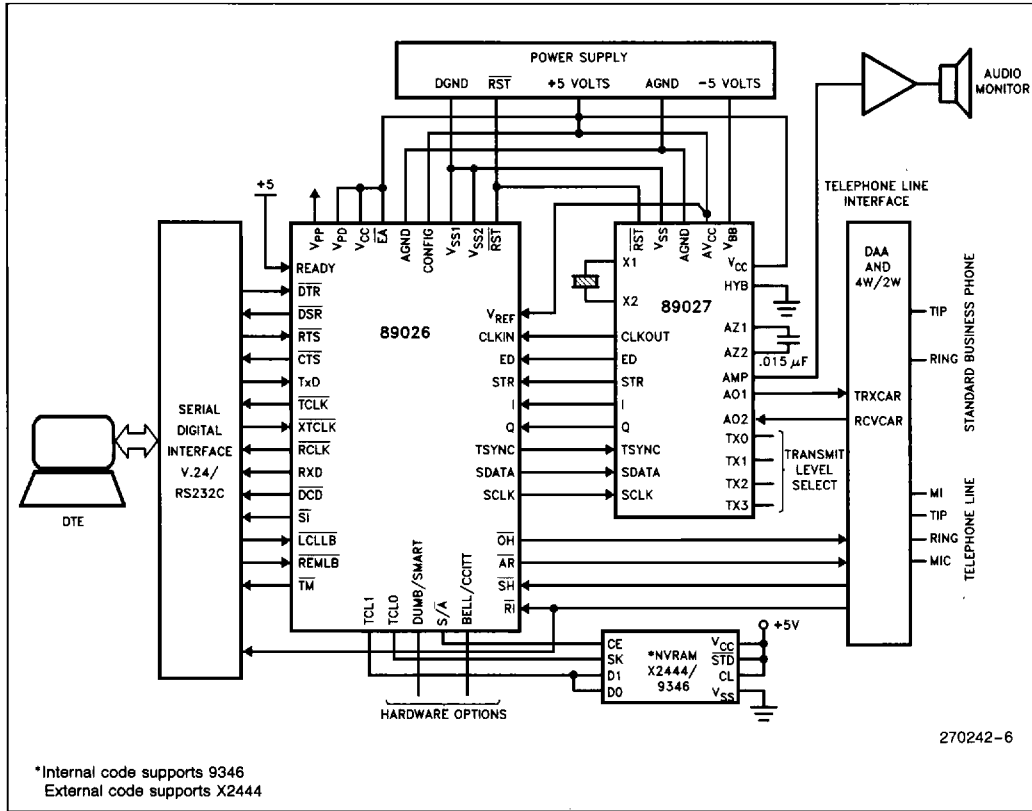

Figure 3. Typical Modem Configuration with External Hybrid

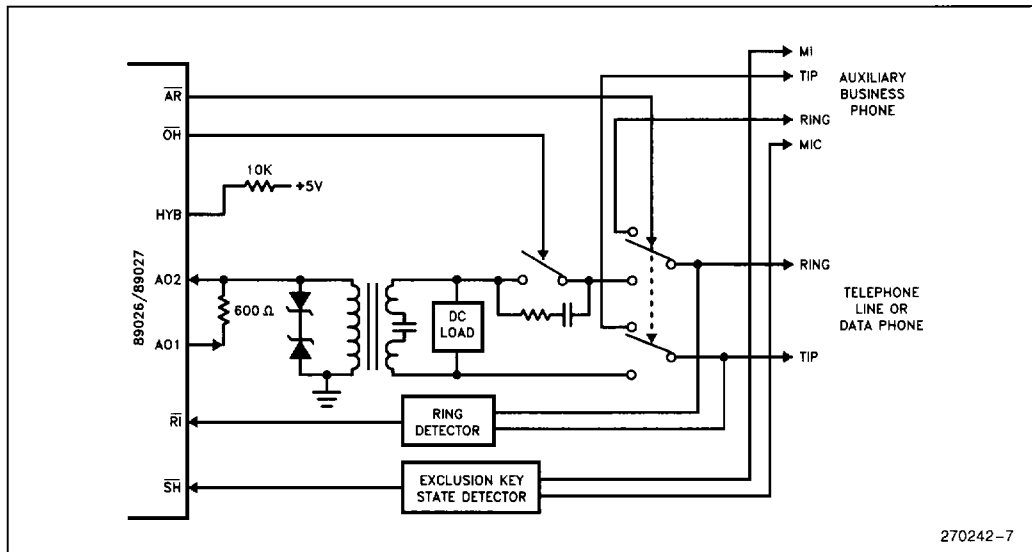

Figure 4. Typical Telephone Line Interface Using Internal Hybrid

1

SYSTEM COMPATIBILITY SPECIFICATIONS

Parameter	Specification
Synchronous*	2400 bps \pm 0.01% V.22 bis 1200 bps \pm 0.01% V.22 and BELL 212A
Asynchronous	2400, 1200 bps, character asynchronous. 0 - 300 bps anisochronous.
Asynchronous Speed Range	+ 1% - 2.5% default. Extended + 2.3% - 2.5% range of CCITT standards optional via software customization.
Asynchronous Format	10 bits, including start, stop, parity. 8, 9, 11 bits optional via S/W customization.
Synchronous Timing Source*	a) Internal, derived from the local oscillator. b) External, provided by DTE through XTCLK. c) Slave, derived from the received clock.
Telephone Line Interface	Two wire full duplex over public switched network or 4 wire leased lines. On-chip hybrid and billing delay timers.
Modulation	V.22 bis, 16 point QAM at 600 baud. V.22 and 212A, 4 point PSK at 600 baud. V.21 and 103, binary phase coherent FSK
Output Spectral Shaping	Square root of 75% raised cosine, QAM/PSK.
Transmit Carrier Frequencies V.22 bis, V.22, 212A	Originate 1200 Hz \pm .01% Answer 2400 Hz \pm .01%
V.21	Originate 'space' 1180 Hz \pm .01% Originate 'mark' 980 Hz \pm .01% Answer 'space' 1850 Hz \pm .01% Answer 'mark' 1650 Hz \pm .01%
Bell 103 mode	Originate 'space' 1070 Hz \pm .01% Originate 'mark' 1270 Hz \pm .01% Answer 'space' 2020 Hz \pm .01% Answer 'mark' 2225 Hz \pm .01%
Receive Carrier Frequency Limits V.22 bis, V.22, 212A	Originate 2400 Hz \pm 7 Hz Answer 1200 Hz \pm 7 Hz
V.21	Originate 'space' 1850 Hz \pm 12 Hz Originate 'mark' 1650 Hz \pm 12 Hz Answer 'space' 1180 Hz \pm 12 Hz Answer 'mark' 980 Hz \pm 12 Hz
Bell 103	Originate 'space' 2020 Hz \pm 12 Hz Originate 'mark' 2225 Hz \pm 12 Hz Answer 'space' 1070 Hz \pm 12 Hz Answer 'mark' 1270 Hz \pm 12 Hz
Typical Energy Detect Sensitivity	Greater than -43 dBm ED is ON. Less than -48 dBm ED is OFF. Signal in dBm measured at A02.
Energy Detect Hysteresis	A minimum Hysteresis of 2 dB for QAM scrambled mark.
Line Equalization	Fixed compromise equalization, transmit. Adaptive equalizer for PSK/QAM, receive.
Diagnostics Available	Local analog loopback. Local digital loopback. Remote digital loopback.
Self Test Pattern Generator	Alternate 'ones' and 'zeros' and error detector, to be used along with most loopbacks. A number indicating the bit errors detected is sent to DTE.

*External code only.

RECEIVER PERFORMANCE

Test Cases		Typical SNR for 10 ⁻⁵ BER Performance	
Data Mode	Rx Level (dBm)	Answer (dB)	Originate (dB)
V.22 bis Synchronous	-30	16	16.5
	-40	16.5	18
V.22/Bell 212A Synchronous	-30	6.5	6.5
	-40	6.5	6.5
V.21 Asynchronous	-30	9	7.5
	-40	9	8
Bell 103 Asynchronous	-30	10	11.5
	-40	10	11.5

1
Test Conditions:

- Receive signal (Rx) measured at A02 (transmit level set at -9 dBm)
- Unconditioned 3002 line
- 3 kHz Flat-band Noise

PERFORMANCE SPECIFICATIONS

Parameter	Min	Typ	Max	Units	Comments
DTMF Level		4.0		dBm	at AO1
DTMF Second Harmonic			-35	dB	HYB enabled into 600Ω
DTMF Twist (Balance)		3		dB	
DTMF Duration		100		ms	Software Controlled
Pulse Dialing Rate		10		pps	
Pulse Dialing Make/Break		39/61		%	US
		33/67		%	UK, Hong Kong
Pulse Interdigit Interval		785		ms	
Billing Delay Interval			2.1	sec	
Guard Tone Frequency Amplitude		540		Hz	referenced to High Channel transmit. QAM/PSK Modes Only
		-3		dB	
Frequency Amplitude		1800		Hz	
		-6		dB	
Dial Tone Detect Duration		3.0		sec	
Ringback Tone Detect Duration Cadence		0.75		sec	Off/On Ratio
		1.5			
Busy Tone Detect Duration Cadence	0.67	0.2	1.5	sec	Off/On Ratio

89026 OVERVIEW

The 89026 processor performs data manipulation, signal processing and user interface functions. It supports an external ROM, for user designed software. This option allows customer designed code to control the signal processing algorithms resident in the 89026. For example proprietary modem control and call progress management applications can be implemented using EPROMs or alternatively by having it burnt in the processor ROM (done so by Intel factory contracting). On-chip ROM is 8 Kbytes. A block diagram of 89026 is in Figure 5.

89026 contains a TTL compatible serial link to DTE/DCE equipment, along with a full complement of V.24/RS-232-C control signals. Alternatively, UART or USART may be used to directly transfer data to and from a microcomputer bus. The 89024 supports the industry standard AT command set, facilitating compatibility with most PC software.

In the transmit operation, the 89026 synthesizes DTMF tones and the 300 bps FSK modem signal prior to transmitting them to the 89027 as digitized amplitude samples. During 1200 and 2400 bps operation, PSK and QAM is used to send 2 or 4 bits of information respectively at 600 baud to 89027. Since the QAM coding technique is an inherently synchronous transmission mechanism, during asynchronous QAM transmission, the asynchronous data is synchronized by adding or deleting stop bits. Following the synchronization process, the 89026 transmits digitized phase and amplitude samples to 89027 over a high speed serial link.

In the receive operation, the information is received by 89026 from 89027 as two signals which are 90 degrees phase shifted from each other. These analog signals are then digitized by the 89026's on-board A/D converter, and using DSP software algorithms the signals are gain adjusted, adaptively equalized for telephone line delay and amplitude distortion, and demodulated. Following the demodulation process by the 89026, the data is unscrambled, and if necessary, returned to asynchronous format.

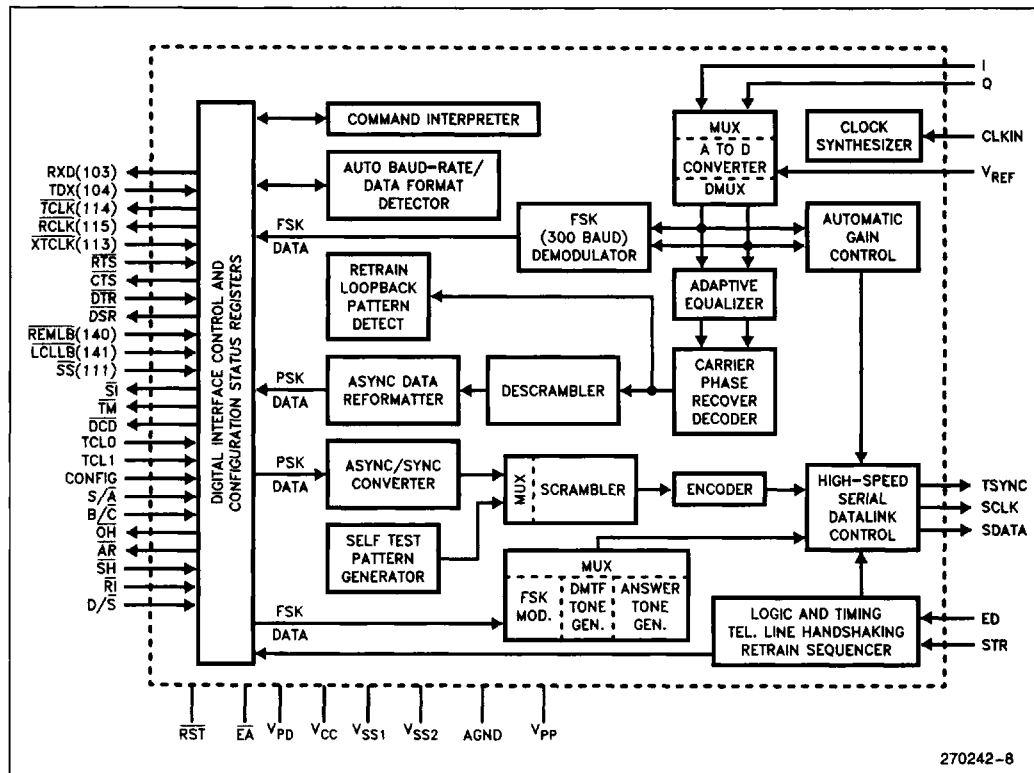

Figure 5. 89026 Block Diagram

89026 PINOUT

Symbol	Function (89026)	Direction	Pin No.
			68 pin
CLKIN	12.96 MHz master clock from 89027	In	67
RST	Chip reset (active low)	In	16
I	In-phase received signal	In	11
Q	Quadrature-phase received signal	In	10
STR	Symbol Timing from 89027	In	24
ED	Energy Detect input	In	9
TSYNC	Transmitter sync pulse to 89027	Out	35
SDATA	Serial Data to 89027	Out	17
SCLK	Serial Clock to 89027	Out	18
OH	Off-Hook control to DAA	Out	33
SH*	Switch-Hook from dataphone	In	44
RI	Ring Indicator from DAA	In	42
AR	Aux Relay control to DAA	Out	38
TCL1	NVRAM Data I/O	I/O	20
TCL0	NVRAM CLK	Out	19
B/C*	103/V.21 default option	In	15
S/A	NVRAM CE	Out	21
D/S	Dumb/Smart mode select	In	6
CONFIG	Reserved for future use (V _{CC}) ⁽³⁾	In	8
TM	Test Mode Indicator	Out	39
TXD	Transmitted data from DTE	In	27
RXD	Received data to DTE	Out	29
RTS	Request to send from DTE	In	22
CTS	Clear to Send to DTE	Out	23
DSR	Data Set Ready to DTE	Out	30
DCD	Data Carrier Detect to DTE	Out	31
DTR	Data Terminal Ready from DTE	In	25
RCLK	Received clock to DTE	Out	34
TCLK	Transmit clock to DTE	Out	28
XTCLK*	External timing clock from DTE	In	26
SI	Speed Indicator to DTE	Out	32
SS	(Note 4)	In	5
REMLB*	Remote Loopback Command from DTE	In	7
LCLLB*	Local Loopback Command from DTE	In	4
V _{CC}	Positive power supply (+ 5V)	+ 5V	1
V _{PD}	Ram back-up power (V _{CC}) ⁽³⁾	+ 5V	14
V _{REF}	A/D converter reference	+ 5V	13
V _{SS1}	Digital ground	GND	36
V _{SS2}	Digital ground	GND	68
AGND	Analog ground	AGND	12
V _{PP}	(NC) ⁽²⁾	In	37
EA	External Memory enable	In	2
AD0-AD15	External memory access address/data ⁽⁵⁾	I/O	60-45
AA	Auto Answer ⁽⁵⁾	Out	60
JS	Jack Select ⁽⁵⁾	Out	59
CD	Carrier Detect Indicator ⁽⁵⁾	Out	58
MR	Modem READY Indicator ⁽⁵⁾	Out	57

*Available in external code only.

1

89026 PINOUT (Continued)

Symbol	Function (89026)	Direction	Pin No.
			68 pin
NMI	No-maskable Interrupt(V_{SS}) ⁽¹⁾	In	3
X2	Crystal output(NC) ⁽²⁾	Out	66
CLKOUT	Clk output (NC) ⁽²⁾	Out	65
BUSWIDTH	Bus Width (V_{CC}) ⁽³⁾	In	64
INST	External memory instruction fetch	Out	63
ALE	Address latch enable	Out	62
\overline{RD}	External memory read	Out	61
READY	External memory ready(V_{CC}) ⁽³⁾	In	43
\overline{BHE}	External memory bus high enable	Out	41
\overline{WR}	External memory write	Out	40

NOTES:

1. Pins marked with (V_{SS}) must be connected to V_{SS} .
2. Pins marked with (NC) are to be left unconnected.
3. Pins marked with (V_{CC}) must be connected to V_{CC} .
4. \overline{SS} pin reserved for future use.
5. With internal ROM enabled, AD0–AD3 are used as \overline{AA} , \overline{JS} , \overline{CD} and \overline{MR} respectively.
6. Pins with direction "In" must not be left floating.

89026 PIN DESCRIPTION

 \overline{XTCLK} *

Transmitter timing from DTE, when external clock option is selected.

TXD

The serial data from DTE to be transmitted on the line. A logic 'high' is mark. In synchronous mode, 89026 samples this data on the rising edges of \overline{TCLK} .

 \overline{TCLK} *

Clock output from 89026 as timing source for data exchange from DTE to modem. Serial data is read on the rising edges of the \overline{TCLK} . This output is High in asynchronous mode.

RXD

The serial data to DTE. 'Mark' is a logic High. In synchronous mode, the rising edge of \overline{RCLK} occurs in the middle of RXD.

 \overline{RCLK} *

Synchronous clock output. Rising edge of \overline{RCLK} occurs in the middle of each RXD bit. This pin remains High in asynchronous mode.

 V_{PP}

This function is not used and should not be connected.

 \overline{TM}

A Low indicates maintenance condition in the modem.

 \overline{DCD}

In async operation, \overline{DCD} remains Low regardless of data carrier (default), or it can be programmed to indicate received carrier signal is within the required timing and amplitude limits. In sync operation Low indicates the received carrier signal is within the required timing and amplitude limits.

 \overline{DSR}

Low indicates modem is off-hook, and it is in data transmission mode, and the answer tone is being exchanged. \overline{CTS} Low indicates modem is prepared to accept data.

RTS

In async mode \overline{RTS} is ignored. Under command control, in sync mode \overline{RTS} can be ignored, or the modem can respond with a Low on \overline{CTS} .

 \overline{DTR}

&D0 command will cause the modem to ignore \overline{DTR} . For &D1 the modem assumes the asynchronous command state on a Low to High transition of the \overline{DTR} circuit. The &D2 command does the same as &D1 except the state of \overline{DTR} will enable/disable auto answer. A Low to High transition of \overline{DTR} after the &D3 command will cause the modem to assume the initialization state.

 B/\overline{C} *

Low configures the modem to CCITT V.21. High will configure the modem to Bell 103, when at 300 bps speed. This pin only affects the modem in FSK operation.

*External code only.

TCL1, TCL0

These pins are used as the serial clock and data for interface to an NVRAM. Refer to Figure 3. TCL0 is used to output a clock and serial data is transferred on TCL1.

AR

This Auxiliary relay control is for switching a relay for voice or data calls. High is voice, Low is data.

RI

A Low signal from DAA indicates line ringing. This input is ignored when the modem is configured for leased line. This signal should follow the ring cadence.

OH

Low sets an off hook condition, high sets an on hook. When dialing, this signal is used to pulse dial the line.

SH*

Used as a telephone voice to data switch or vice versa. Any logic level transition will toggle the modem state. This input is ignored, if a software command attempts to switch the modem between voice and data.

AA

Used as an indicator for Auto Answer status and Ring indicator. Active low.

LCLLB*

A Low will set the modem in the local analog loopback test mode. Logic Low levels applied simultaneously to REMLB and LCLLB pins, sets the modem to the local digital loopback.

REMLB*

A logic Low on this pin initiates a remote loopback condition.

*External code only

89026 ABSOLUTE MAXIMUM RATINGS**

Temperature Under Bias 0°C to +70°C
 Storage Temperature -40°C to +125°C
 Voltage from Any Pin to
 V_{SS} or AGND -0.3V to +7.0V
 Average Output Current from Any Pin 10 mA
 Power Dissipation 1.5 Watts

SI

Selects one of the two data rates or ranges of rates in the DTE to correspond to the rate in modem. Low selects the higher rate (2400 CCITT/1200 BELL) or range of rates. High selects the Low rate or range of rates.

D/S

A Low on this pin will indicate the smart mode which will respond to all commands. A High will ignore all commands.

V_{REF}

Voltage reference for the analog to digital converter should be connected to the 89027 AVcc.

V_{PD}

The internal RAM power down supply voltage to be connected to 5 Volts during normal operation.

S/A

The function of this pin is re-defined as external NVRAM CE.

CONFIG

Reserved for future use. This signal should be pulled high.

EA

When High, memory access from address 2000H to 4000H are directed to on-chip ROM. When Low, all memory access is directed to off-chip memory.

JS

Low is used to pulse A and A1 leads to control a 1A2 Key System jack.

CD

A low indicates the presence of carrier signal on the line.

MR

A low indicates the presence of the DSR signal. Toggling indicates that a test move is active.

NOTICE: This is a production data sheet. The specifications are subject to change without notice.

**WARNING: Stressing the device beyond the "Absolute Maximum Ratings" may cause permanent damage. These are stress ratings only. Operation beyond the "Operating Conditions" is not recommended and extended exposure beyond the "Operating Conditions" may affect device reliability.*

1

OPERATING CONDITIONS

Symbol	Parameter	Min	Max	Units
TA	Ambient Temperature Under Bias	0	+70	°C
V _{CC}	Digital Supply Voltage	4.75	5.25	V
V _{REF}	Analog Supply Voltage	4.75	5.25	V
FREQ	CLKIN Frequency 12.96 MHz	-0.01%	+0.01%	
V _{PD}	Power-Down Supply Voltage	4.75	5.25	V

NOTE:

The AGND and V_{SS} on both the 89026 and the 89027 must be nominally at the same potential.

D.C. CHARACTERISTICS Test Conditions: V_{CC}, V_{REF}, V_{PD}, V_{PP}, V_{EA} = 5.0V ± 0.25V;
F_{OSC} = 12.96 MHz; T_A = 0°C to 70°C, V_{SS}, AGND = 0V

Symbol	Parameter	Min	Max	Units	Test Conditions
I _{CC}	V _{CC} Supply Current (0°C ≤ T _A ≤ 70°C)		240	mA	All Outputs Disconnected
I _{CC1}	V _{CC} Supply Current (T _A = 70°C)		185	mA	
I _{PD}	V _{PD} Supply Current		1	mA	Normal Operation and Power-Down
I _{REF}	V _{REF} Supply Current		8	mA	
V _{IL}	Input Low Voltage	-0.3	+0.8	V	
V _{IH}	Input High Voltage (Except RESET, NMI, CLKIN)	2.0	V _{CC} + 0.5	V	
V _{IH1}	Input High Voltage, RESET Rising	2.4	V _{CC} + 0.5	V	
V _{IH2}	Input High Voltage, RESET Falling Hysteresis	2.1	V _{CC} + 0.5	V	
V _{IH3}	Input High Voltage, NMI, CLKIN	2.2	V _{CC} + 0.5	V	
I _{LI}	Input Leakage Current ⁽¹⁾		±10	μA	V _{IN} = 0 to V _{CC}
I _{LI1}	D.C. Input Leakage Current ⁽²⁾		+3	μA	V _{IN} = 0 to V _{CC}
I _{IH}	Input High Current to \overline{EA}		100	μA	V _{IH} = 2.4V
I _{IL}	Input Low Current ⁽³⁾		-125	μA	V _{IL} = 0.45V
I _{IL1}	Input Low Current to RESET	-0.25	-2	mA	V _{IL} = 0.45V
I _{IL2}	Input Low Current, READY, BUSWIDTH ⁽⁴⁾		-50	μA	V _{IL} = 0.45V
V _{OL}	Output Low Voltage ⁽⁵⁾		0.45	V	I _{OL} = 0.8 mA
V _{OL1}	Output Low Voltage ⁽⁵⁾		0.75	V	I _{OL} = 2.0 mA
V _{OL2}	Output Low Voltage ⁽⁶⁾ RESET and Bus/Control Pins		0.45	V	I _{OL} = 2.0 mA
V _{OH}	Output High Voltage ⁽⁵⁾	2.4		V	I _{OH} = -20 μA
V _{OH1}	Output High Voltage on Bus Control Pins ⁽⁷⁾	2.4		V	I _{OH} = -200 μA
I _{OH3}	Output High Current on RESET	-50		μA	V _{OH} = 2.4V
C _S	Pin Capacitance (Any Pin to V _{SS})		10	pF	f _{TEST} = 1.0 MHz

NOTES:

- STR, DTR, XTCLK, TXD
- S/D, SS, REMLB, LCLLB, I, Q, CONFIG, ED
- TCLK1, RTS
- Also, B/C, SH, FI
- TCL0, S/A, CTS, DSR, DCD, SI, OH, AR
- SCLK, SDATA, TM, TCLK, RXD, RCLK, TSYNC
- Bus/Control pins include CLKOUT, ALE, BHE, RD, WR, INST and AD0-15.

AC CHARACTERISTICS (V_{CC} , V_{PD} = 4.75 to 5.25 Volts; T_A = 0°C to 70°C; CLKIN = 12.96 MHz)

Test Conditions: Load capacitance on output pins = 80 pF

$$T_{OSC} = 1/12.96 \text{ MHz}$$

TIMING REQUIREMENTS (Other system components must meet these specs.)

Symbol	Parameter	Min	Max	Units
T_{CLYX}	READY Hold after CLKOUT Edge	0		ns
T_{LLYV}	End of ALE/ \overline{ADV} to READY Valid		$2T_{OSC} - 70$	ns
T_{LLYH}	End of ALE/ \overline{ADV} to READY High	$2T_{OSC} + 40$	$4T_{OSC} - 80$	ns
T_{YLYH}	Non-Ready Time		1000	ns
$T_{AVDV}^{(1)}$	Address Valid to Input Data Valid		$5T_{OSC} - 120$	ns
T_{RLDV}	\overline{RD} Active to Input Data Valid		$3T_{OSC} - 100$	ns
T_{RHDX}	Data Hold after \overline{RD} Inactive	0		ns
T_{RHDX}	\overline{RD} Inactive to Input Data Float	0	$T_{OSC} - 25$	ns
$T_{AVGV}^{(1)}$	Address Valid to BUSWIDTH Valid		$2T_{OSC} - 125$	ns
T_{LLGX}	BUSWIDTH Hold after ALE/ \overline{ADV} Low	$T_{OSC} + 40$		ns
T_{LLGV}	ALE/ \overline{ADV} Low to BUSWIDTH Valid		$T_{OSC} - 75$	ns

NOTE:

 1. The term "Address Valid" applies to AD0-15, \overline{BHE} and INST.

TIMING RESPONSES

Symbol	Parameter	Min	Max	Units
F_{CLKIN}	Oscillator Frequency	12.95870	12.96129	MHz
T_{OSC}	Oscillator Period	$1/F_{CLKIN(MAX)}$	$1/F_{CLKIN(MIN)}$	ns
T_{OHCH}	Rising Edge to Clock Rising Edge	0	120	ns
T_{CHCH}	CLKOUT Period ⁽²⁾	$3T_{OSC}^{(2)}$	$3T_{OSC}^{(2)}$	ns
T_{CHCL}	CLKOUT High Time	$T_{OSC} - 35$	$T_{OSC} + 10$	ns
T_{CLLH}	CLKOUT Low to ALE High	-20	+25	ns
T_{LLCH}	ALE/ \overline{ADV} Low to CLKOUT High	$T_{OSC} - 25$	$T_{OSC} + 45$	ns
T_{LHLL}	ALE/ \overline{ADV} High Time	$T_{OSC} - 30$	$T_{OSC} + 35^{(3)}$	ns
$T_{AVLL}^{(4)}$	Address Setup to End of ALE/ \overline{ADV}	$T_{OSC} - 50$		ns
T_{RLAZ}	\overline{RD} or \overline{WR} Low to Address Float	Typ. = 0	10	ns
T_{LLRL}	End of ALE/ \overline{ADV} to \overline{RD} or \overline{WR} Active	$T_{OSC} - 40$		ns
$T_{LLAX}^{(5)}$	Address Hold after End of ALE/ \overline{ADV}	$T_{OSC} - 40$		ns
T_{WLWH}	\overline{WR} Pulse Width	$3T_{OSC} - 35$		ns
T_{QVWH}	Output Data Valid to End of $\overline{WR}/\overline{WRL}/\overline{WRH}$	$3T_{OSC} - 60$		ns
T_{WHQX}	Output Data Hold after $\overline{WR}/\overline{WRL}/\overline{WRH}$	$T_{OSC} - 50$		ns
T_{WHLH}	End of $\overline{WR}/\overline{WRL}/\overline{WRH}$ to ALE/ \overline{ADV} High	$T_{OSC} - 75$		ns
T_{RLRH}	\overline{RD} Pulse Width	$3T_{OSC} - 30$		ns
T_{RHLH}	End of \overline{RD} to ALE/ \overline{ADV} High	$T_{OSC} - 45$		ns

89027 OVERVIEW

The 89027 is a 28 pin CMOS analog front end device, which performs most of the complex filtering functions required in modem transmitters and receivers. A general block diagram of this chip is provided in Figure 7. Most of the analog signal processing functions in this chip are implemented with CMOS switched capacitor technology. The 89027 functions are controlled by 89026, through a high speed serial data link.

During FSK transmit operation, the 89027 receives digitally synthesized mark and space sinusoid amplitude information from the 89026. The 89027 converts the signal to its analog equivalent, filters it, and transmits it to the telephone line. For QAM transmission, the signal constellation points are transferred to the 89027. This information is modulated into an analog signal, passed through spectral shaping fil-

ters, combined with the necessary guard tone, smoothed by a low pass filter, and transmitted to the line. Prior to transmitting either FSK or QAM signals to the telephone line, the 89027 adjusts the signal gain through an on-board programmable gain amplifier.

During the receive operation, the received FSK and QAM signals are passed through anti-alias filters, bandsplit filters, automatic gain control and carrier detect circuits, a Hilbert transform filter, and the output sent to the 89026 processor as analog signals.

Other functions provided by the 89027 are: an on-board two wire to four wire circuit with disable capability, an audio monitor output with software configurable gain, and a programmable gain transmit signal.

The 89027 is available in 28 pin plastic DIP and PLCC packages.

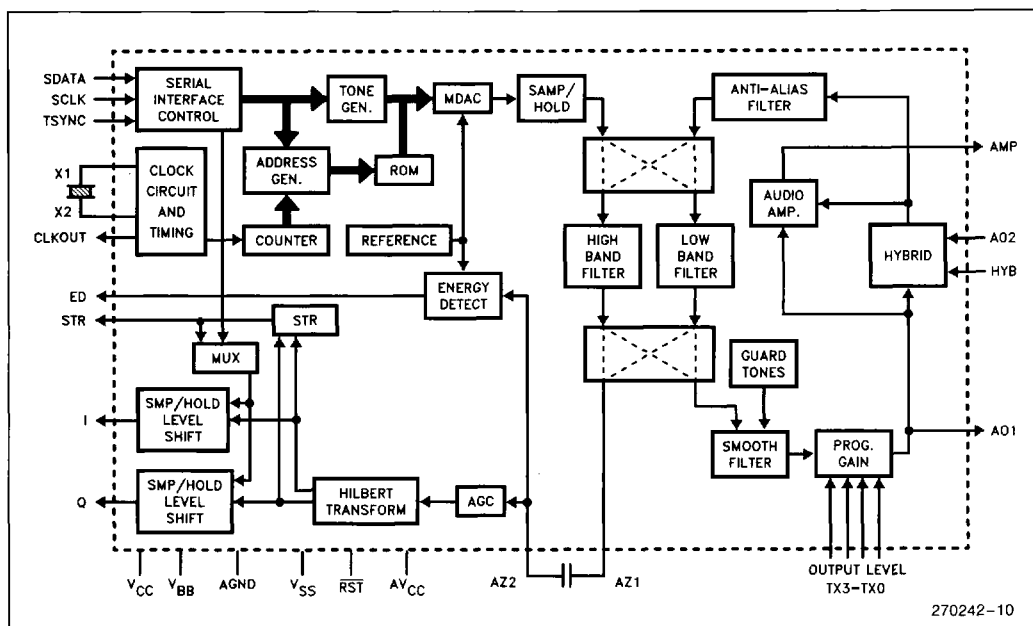

Figure 7. 89027 Block Diagram

89027 PINOUT

Symbol	Function (89027)	Direction	Pin No.
V _{CC}	Positive Power Supply (Digital)	+ 5V	28
V _{BB}	Negative Power Supply	- 5V	15
V _{SS}	Digital Ground	DGND	24
AGND	Analog Ground	AGND	21
AV _{CC}	Positive Power Supply (Analog)	+ 5	7
X1	Xtal Oscillator	In	23
X2	Xtal Oscillator	Out	25
CLKOUT	12.96 MHz Clock Output to 89026	Out	26
RST	Chip reset (active low) ⁽¹⁾	In	20
HYB	Enable on-chip hybrid ⁽¹⁾	In	10
AZ1	Auto-zero capacitor	Out	16
AZ2	Auto-zero capacitor	In	17
SDATA	Serial data from 89026	In	2
SCLK	Serial clock from 89026	In	1
TSYNC	Transmitter sync from 89026	In	3
STR	Symbol timing to 89026	Out	27
ED	Receiver energy detect to 89026	Out	18
I	In phase received signal to 89026	Out	13
Q	Quadrature-phase received signal to 89026	Out	14
AO1	Transmitter output	Out	6
AO2	Receiver input	In	12
AMP	Output to monitor speaker	Out	11
TX0	Transmitter level control (LSB) ⁽¹⁾	In	9
TX1	Transmitter level control ⁽¹⁾	In	8
TX2	Transmitter level control ⁽¹⁾	In	5
TX3	Transmitter level control (MSB) ⁽¹⁾	In	4
NC	(Note 2)	Out	19
NC	(Note 3)	In	22

NOTES:

1. When held high, these pins must be connected through 10K resistors to V_{CC}.
2. Must be left No Connect. Will affect operation of 89027
3. Reserved Pin. Must be left No Connect.

89027 Pinout Description**TX0-3**

These four pins control the transmitted signal level. Refer to Transmit Level Table.

HYB

This pin enables the on-chip hybrid. A line impedance matching network must be connected between AO1 and AO2 when HYB is enabled. If HYB is disabled and an external 4W/2W hybrid is used, the hybrid receive path must be amplified by 6 dB.

AO1

Transmitter output.

AO2

Receiver input.

AMP

This output can be used to monitor the call progress tones and operation of the line.

ABSOLUTE MAXIMUM RATINGS*

Temperature Under Bias	− 0 to + 70°C
Storage Temperature	− 40 to + 125°C
All Input and Output Voltages with Respect to V_{BB}	− 0.3V to + 13.0V
All Input and Output Voltages with Respect to V_{CC} & AV_{CC}	− 13.0V to 0.3V
Power Dissipation	1.35W
Voltage with Respect to $V_{SS}^{(1)}$	− 0.3V to 6.5V

NOTE:

1. Applies to pins SCLK, SDATA, TSYNC, \overline{RST} , HYB, TX0–TX3 only.

NOTICE: This is a production data sheet. The specifications are subject to change without notice.

**WARNING: Stressing the device beyond the "Absolute Maximum Ratings" may cause permanent damage. These are stress ratings only. Operation beyond the "Operating Conditions" is not recommended and extended exposure beyond the "Operating Conditions" may affect device reliability.*

1

POWER DISSIPATION Ambient Temp = 0°C to 70°C, $V_{CC} = AV_{CC} = 5V \pm 5\%$, $V_{SS} = AGND = 0V$.

Symbol	Parameter	Min	Typ	Max	Units
I_{CC1}	AV_{CC} Operating Current		15	21	mA
I_{CC1}	V_{CC} Operating Current		5	6	mA
I_{BB1}	V_{BB} Operating Current		− 15	− 21	mA
I_{CCS}	AV_{CC} Standby Current		0.2	1	mA
I_{CCS}	V_{CC} Standby Current		5	6	mA
I_{BBS}	V_{BB} Standby Current		− 0.6	− 2	mA
P_{DO}	Operating Power Dissipation		175	250	mW
P_{DS}	Standby Power Dissipation		30	50	mW

DC CHARACTERISTICS ($T_a = 0^\circ\text{C}$ to 70°C , $AV_{CC} = V_{CC} = 5V \pm 5\%$, $V_{BB} = 5V \pm 5\%$, $AGND = V_{SS} = 0V$), supply voltage must be at the same potential as the 89026 power supply. Typical Values are for $T_a = 25^\circ\text{C}$ and nominal power supply values. V_{CC} , AV_{CC} and 89026 V_{REF} must be nominally at the same potential.

Inputs: TX0, TX1, TX2, TX3, HYB, \overline{RST}

Outputs: CLKOUT

Symbol	Parameter	Min	Max	Units	Test Condition
I_{IL}	Input Leakage Current	− 10	+ 10	μA	$V_{SS} \leq V_{in} \leq V_{CC}$
V_{IL}	Input Low Voltage	V_{SS}	0.8	V	
V_{IH}	Input High Voltage	2.4	V_{CC}	V	
V_{OL}	Output Low Voltage		0.4	V	$I_{OL} \geq -1.6\text{mA}$, 1 TTL load
V_{OH}	Output High Voltage	2.4		V	$I_{OH} \leq 50\mu\text{A}$, 1 TTL load
V_{COL}	CLKOUT Low Voltage		0.4	V	Load Capacitance = 60 pF
V_{COH}	CLKOUT High Voltage	0.7 V_{CC}		V	Load Capacitance = 60 pF

AC CHARACTERISTICS ($T_a = 25^\circ\text{C}$, $V_{CC} = AV_{CC} = 5\text{V}$, $V_{SS} = \text{AGND} = 0\text{V}$, $V_{BB} = -5\text{V}$)**ANALOG INPUTS: AO2**

Parameter	Min	Typ	Max	Units	Test Condition
AO2 Receive Signal			-9	dBm	Hybrid Enabled
AO2 Input Resistance		10		MOhms	$-2.5\text{V} < V_{in} < +2.5\text{V}$
AO2 Allowed DC offset	-30		+30	mV	Relative to AGND

AUTO ZERO CAPACITANCE

Capacitance = $0.015 \mu\text{F}$
 Tolerance = $\pm 20\%$
 Voltage Rating = 10V
 Type = Non-Electrolytic, low leakage.

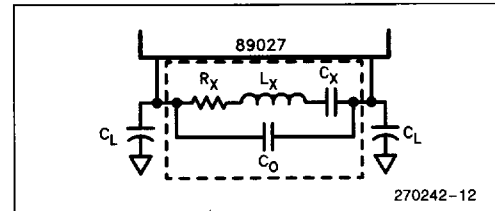

Figure 8. Crystal Equivalent Circuit

CRYSTAL REQUIREMENTS

Parameter	Min	Typ	Max	Unit	Comments
Frequency Accuracy ($0^\circ\text{C} - 70^\circ\text{C}$)	-0.0035%	12.96	+0.0035%	MHz	Refer to Figure 8
Rx		10	16	Ohms	
Cx		0.024		pF	
Co	5.1	5.6	6.1	pF	
CL	-5%	33	+5%	pF	2 Load Capacitors

Crystal Type: Parallel Resonant

ANALOG OUTPUTS: AO1, AMP

Parameter	Min	Typ	Max	Units	Comments
Load Resistance AO1	600			Ohms	
AMP	10			KOhms	
Load Capacitance AMP			100	pF	
Audio Amp Gain AO1 to Amp		-9 -18 -26 -70		dB dB dB dB	Max Mid Min Off Software Selectable
Audio Amp Gain (1) AO2 to Amp		+12 +3 -4 -60		dB dB dB dB	Max Mid Min Off Software Selectable

NOTE:

1. Assumes on-chip hybrid is enabled. When on-chip hybrid is disabled, gain with respect to AO2 is reduced by 6 dB.

TRANSMIT LEVEL

TRANSMIT OUTPUT LEVEL(1)		
TX 3,2,1,0	Typ	Units
0 0 0 0	+5	dBm
0 0 0 1	+4	dBm
•	•	•
•	•	•
•	•	•
1 1 1 0	-9	dBm
1 1 1 1	-10	dBm

NOTE:

1. For PSK and QAM transmit signal. For FSK, signal levels are typically 1 dB lower. All signals are measured at AO1.
2. The tolerance for the above transmit levels are ± 1 dBm.

REFERENCE MANUALS

The *Modem Reference Manual* (Order Number 296235-002) contains pin descriptions, schematics, and important design guidelines for this chipset (89024) as well as for the 89C024LT and 89C024FT modem chip sets.

The *Modem Software Reference Manual* (Order Number 296503-001) provides information about the modem software routines. Contact your local sales office for the latest information.

1

89024 REVISION -006 HISTORY

The following differences exist between Rev. -005 and this version of the data sheet:

1. \overline{CD} and \overline{MR} signal indicator descriptions added.

