

POWER MANAGEMENT

Description

The EZ1584 is a high performance positive voltage regulator designed for use in applications requiring low dropout performance at 7A. Additionally, the EZ1584 series provides excellent regulation over variations in line, load and temperature.

Outstanding features include low dropout performance at rated current, fast transient response, internal current limiting and thermal shutdown protection of the output device.

The EZ1584 is an excellent choice for powering microprocessor systems. Using an LDO eliminates MOSFETs and inductors, saving both space and cost. An LDO also provides better transient response and no ripple.

A variety of options are available for maximum flexibility: the EZ1584C is intended for commercial applications and has both fixed and adjustable voltage options; the EZ1584I is intended for industrial applications and has a 3.3V fixed and an adjustable option. All devices are available in the popular TO-220 package.

Features

- ◆ Low dropout performance: 1.3V max. for EZ1584C and 1.4V max. for EZ1584I
- ◆ Full current rating over line and temperature
- ◆ Fast transient response
- ◆ ±2% total output regulation over line, load and temperature
- ◆ Adjust pin current max 90µA over temperature
- ◆ Fixed/adjustable output voltage
- ◆ Line regulation typically 0.015%
- ◆ Load regulation typically 0.05%
- ◆ Industrial temperature range (EZ1584I)
- ◆ TO-220 package

Applications

- ◆ Memory supply
- ◆ Graphics core supply
- ◆ Other 2.5V to 3.6V microprocessor supplies
- ◆ Low voltage logic supplies
- ◆ Battery-powered circuitry
- ◆ Post regulator for switching supply
- ◆ Telecom supplies
- ◆ Industrial supplies

Typical Application Circuit

Fixed Voltage Regulator

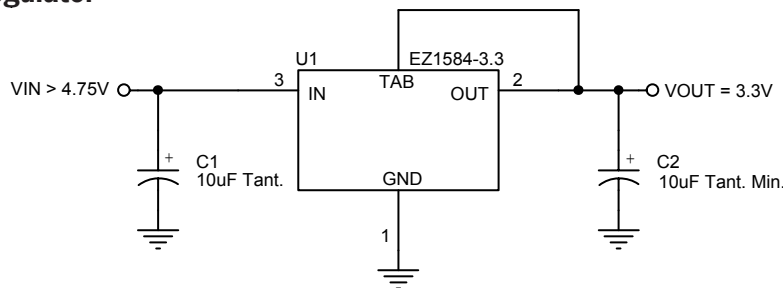

Adjustable Voltage Regulator

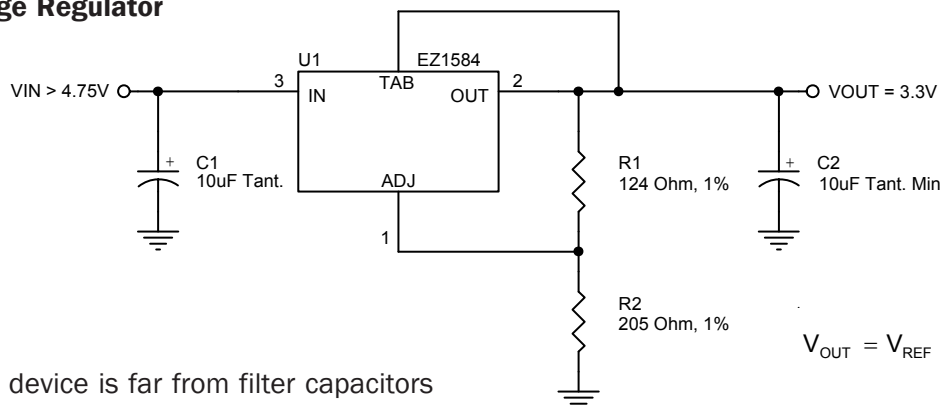

Notes:

- (1) C1 needed if device is far from filter capacitors
- (2) C2 minimum value required for stability

$$V_{OUT} = V_{REF} \cdot \left(1 + \frac{R2}{R1}\right) + I_{ADJ} \cdot R2$$

POWER MANAGEMENT

Absolute Maximum Ratings

Parameter	Symbol	Maximum	Units
Input Supply Voltage	V_{IN}	7	V
Power Dissipation	P_D	Internally Limited	W
Thermal Resistance Junction to Case	θ_{JC}	2	°C/W
Thermal Resistance Junction to Ambient	θ_{JA}	50	°C/W
Operating Ambient Temperature Range EZ1584C EZ1584I	T_A	0 to 70 -40 to 85	°C
Operating Junction Temperature Range EZ1584C EZ1584I	T_J	0 to 125 -40 to 125	°C
Storage Temperature Range	T_{STG}	-65 to 150	°C
Lead Temperature (Soldering) 10 Sec.	T_{LEAD}	300	°C
ESD Rating (Human Body Model)	ESD	2	kV

Electrical Characteristics

Unless otherwise specified: Adj. $V_{IN} = 2.75V$ to $7.0V$ and Adj. $I_O = 10mA$ to $7.0A$; Fixed $V_{IN} = 4.75$ to $7.0V$ and Fixed $I_O = 0$ mA to $7.0A$.
Values in **bold** apply over full operating ambient temperature range.

Parameter	Symbol	V_{IN}	I_O	Min	Typ	Max	Units
Output Voltage ⁽¹⁾ EZ1584C-X.X, EZ1584I-3.3	V_O	5V	0mA	0.99 V_O	V_O	1.01 V_O	V
				0.98V_O		1.02V_O	
Reference Voltage ⁽¹⁾ EZ1584C, EZ1584I	V_{REF}	5V	10mA	1.238	1.250	1.262	V
				1.225		1.275	
Line Regulation ⁽¹⁾	$REG_{(LINE)}$		10mA		0.015	0.2	%
Load Regulation ⁽¹⁾	$REG_{(LOAD)}$	5V			0.05	0.4	%
Dropout Voltage ⁽¹⁾⁽²⁾ EZ1584C, EZ1584C-X.X EZ1584I, EZ1584I-3.3	V_D		7A		1.20	1.30	V
					1.20	1.40	
Current Limit	I_{CL}			7.1	9.0		A

POWER MANAGEMENT
Electrical Characteristics (Cont.)

Unless otherwise specified: Adj. V_{IN} = 2.75V to 7.0V and Adj. I_O = 10mA to 7.0A; Fixed V_{IN} = 4.75 to 7.0V and Fixed I_O = 0 mA to 7.0A.
 Values in **bold** apply over full operating ambient temperature range.

Parameter	Symbol	V_{IN}	I_O	Min	Typ	Max	Units
Quiescent Current Fixed Voltage Versions	I_Q	5V			10	13	mA
Temperature Coefficient	T_C				0.005		%/°C
Adjust Pin Current	I_{ADJ}				55	90	μA
Adjust Pin Current Change	ΔI_{ADJ}				0.2	5	μA
Temperature Stability	T_S	5V	0.5A		0.5		%
Minimum Load Current Adj Voltage Versions	I_O	5V			5	10	mA
RMS Output Noise ⁽³⁾	V_N				0.003		% V_O
Ripple Rejection Ratio ⁽⁴⁾	R_A	5V	7A	60	72		dB

NOTES:

- (1) Low duty cycle pulse testing with Kelvin connections required.
- (2) $\Delta V_{OUT}, \Delta V_{REF} = 1\%$
- (3) Bandwidth of 10 Hz to 10 kHz.
- (4) 120 Hz input ripple (C_{ADJ} for ADJ = 25μF).

POWER MANAGEMENT

Pin Configuration

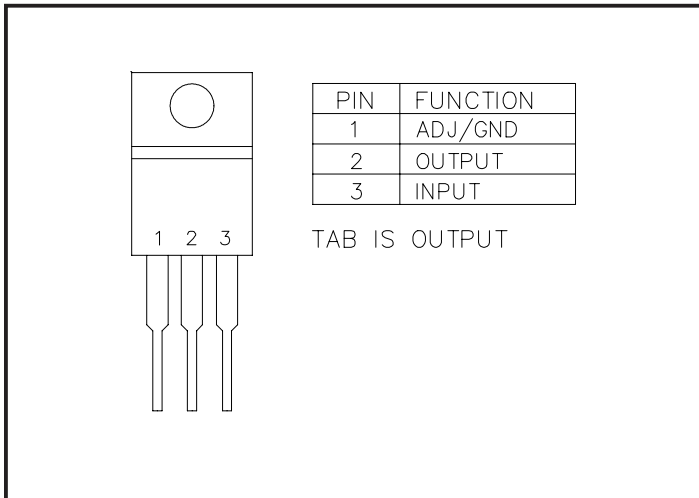

Ordering Information

Device ⁽¹⁾⁽²⁾	Package
EZ1584CT-X.X EZ1584IT-X.X	TO-220 ⁽³⁾⁽⁴⁾

Notes:

- (1) Where X.X denotes voltage options. Available voltages are: 1.5V, 2.5V and 3.3V for EZ1584C and 3.3V only for EZ1584I. Leave blank for adjustable version (1.3V to 5.7V). Contact factory for additional voltage options.
- (2) Where C and I denote Commercial (0°C to 70°C) and Industrial (-40°C to 85°C) ambient temperature ranges.
- (3) Only available in tube packaging. A tube contains 50 devices.
- (4) Halogen Free, and RoHS/WEEE compliant.

Pin Descriptions

Pin	Pin Name	Pin Function
1	ADJUST	This pin is the negative side of the reference voltage for adjustable devices. Transient response can be improved by adding a small bypass capacitor from the adjust pin to ground.
	GROUND	This pin is the bottom end of the internal resistor feedback chain for fixed output voltage parts, and should be connected to ground.
2	OUTPUT	This is the power output of the device and is electrically connected to the TAB.
3	INPUT	This is the input supply pin for both the control circuitry and the pass device.

Block Diagram

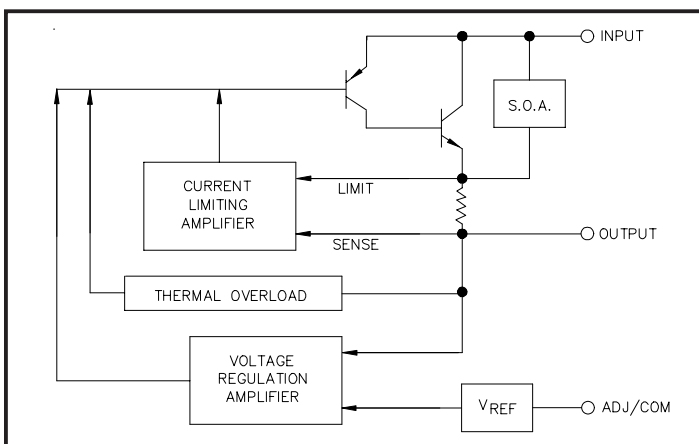

POWER MANAGEMENT

Outline Drawing - TO-220

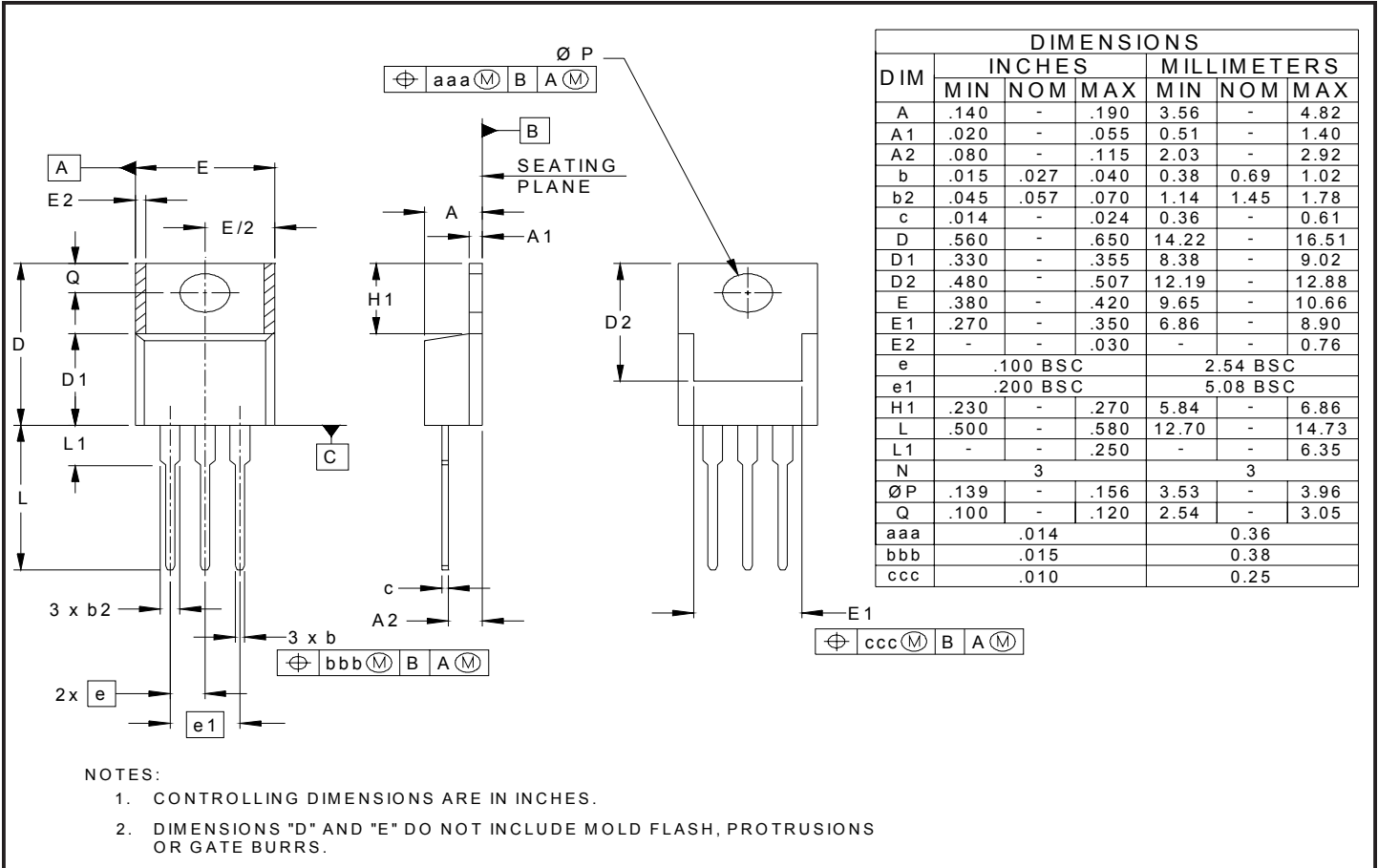

Contact Information

Semtech Corporation
 Power Management Products Division
 652 Mitchell Rd., Newbury Park, CA 91320
 Phone: (805)498-2111 FAX (805)498-3804