

MBRF1040CT THRU MBRF10200CT-HAF

Schottky Barrier Rectifiers

Reverse Voltage - 40 to 200 V

Forward Current - 10 A

Features

- Low power loss
- High efficiency
- Low forward voltage
- High current capability
- Halogen and Antimony Free(HAF), RoHS compliant

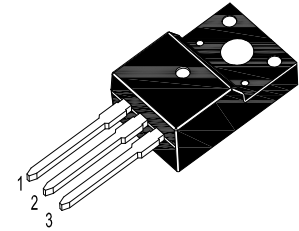

1.Anode 2.Cathode 3.Anode
TO-220F Plastic Package

Mechanical Data

- **Case:**TO-220F, molded plastic body
- **Polarity:** As marked
- **Mounting position:** Any

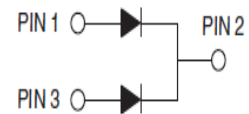

Maximum Ratings and Characteristics

Ratings at 25°C ambient temperature unless otherwise specified.

Parameter	Symbols	MBRF 1040CT	MBRF 1045CT	MBRF 1050CT	MBRF 1060CT	MBRF 10100CT	MBRF 10150CT	MBRF 10200CT	Units
	Marking	MBRF 1040CT	MBRF 1045CT	MBRF 1050CT	MBRF 1060CT	MBRF 10100CT	MBRF 10150CT	MBRF 10200CT	-
Maximum Recurrent Peak Reverse Voltage	V_{RRM}	40	45	50	60	100	150	200	V
Maximum Working Peak Reverse Voltage	V_{RWM}	28	31	35	42	70	105	140	V
Maximum DC Blocking Voltage	V_{DC}	40	45	50	60	100	150	200	V
Max. Average Forward Rectified Current Total Device Per Diode	$I_{F(AV)}$	10 5							A
Peak Forward Surge Current 8.3 ms Single Half Sine Wave Superimposed on Rated Load	I_{FSM}	125							A
Maximum Forward Voltage per Leg at $I_F = 5$ A	V_F	0.55		0.7		0.85	0.95	0.99	V
Maximum DC Reverse Current at Rated DC Blocking Voltage at $T_A = 25^\circ\text{C}$ at $T_A = 100^\circ\text{C}$	I_R	0.5 10			0.5 5			mA	
Thermal Resistance from Junction to Case	$R_{\theta JC}$	3.5							$^\circ\text{C/W}$
Maximum Junction Capacitance at $V_R = 4$ V, $f = 1$ MHz	C_J	400				310			pF
Operating Junction Temperature Range	T_j	- 55 to + 150							$^\circ\text{C}$
Storage Temperature Range	T_{stg}	- 55 to + 150							$^\circ\text{C}$

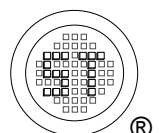

MBRF1040CT THRU MBRF10200CT-HAF

Electrical Characteristics Curves

Fig 1. Forward Current Derating Curve

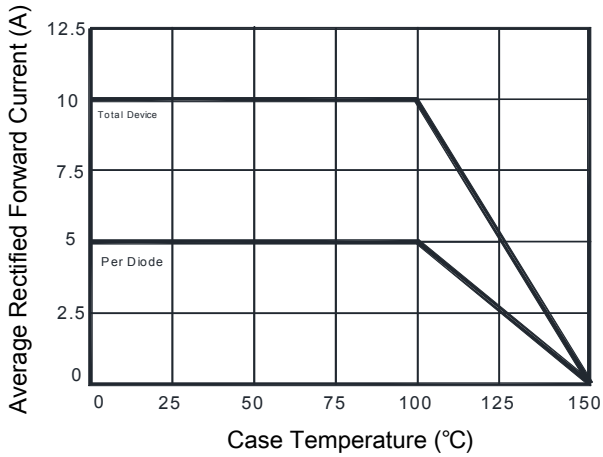

Fig 2. Forward Characteristics Curve

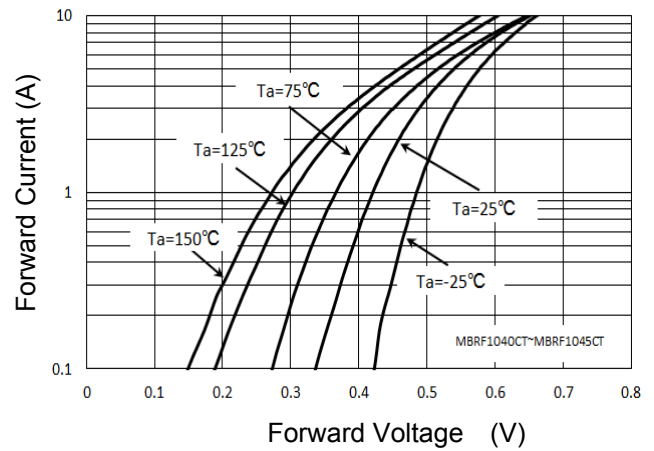

Fig 3. Reverse Characteristics Curve

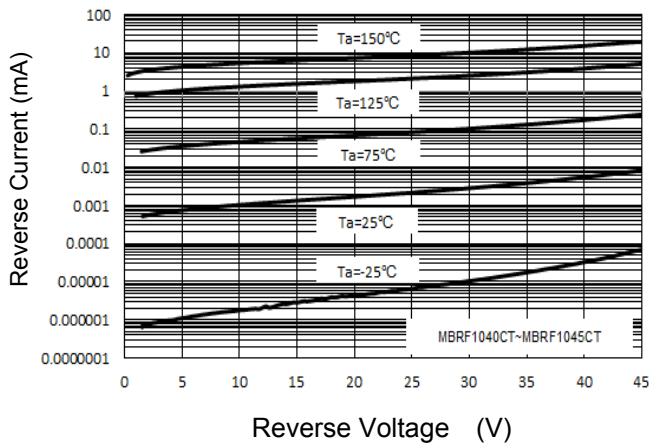

Fig 4. Junction Capacitance

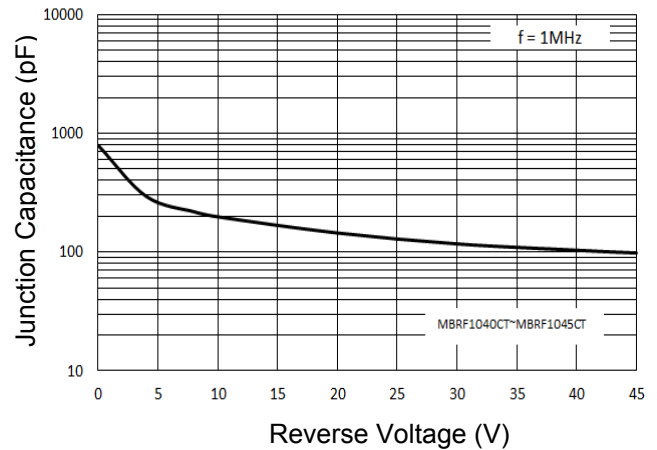
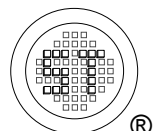
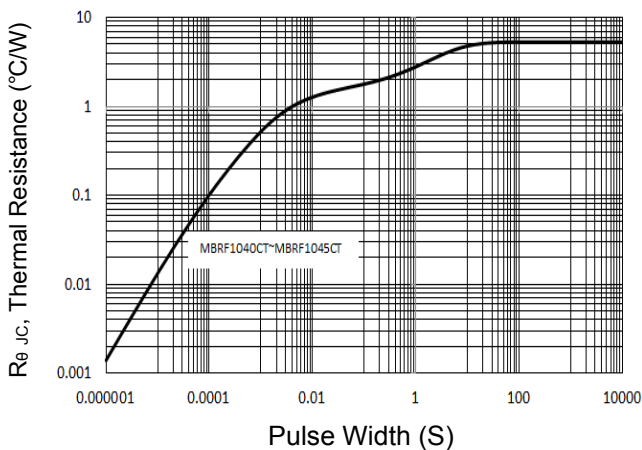

Fig 5. Thermal Resistance Curve



MBRF1040CT THRU MBRF10200CT-HAF

Electrical Characteristics Curves

Fig 6. Reverse Characteristics Curve

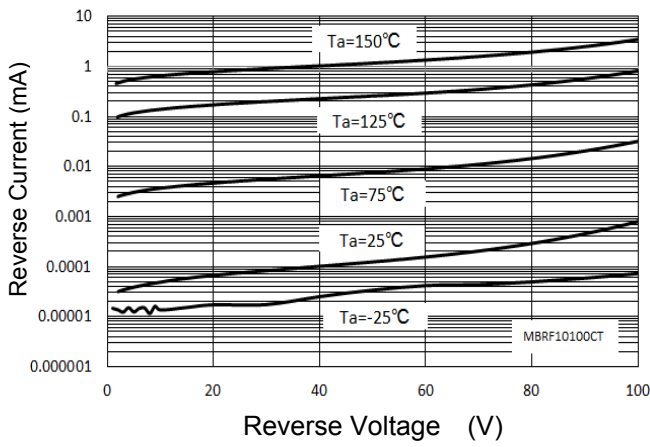

Fig 7. Forward Characteristics Curve

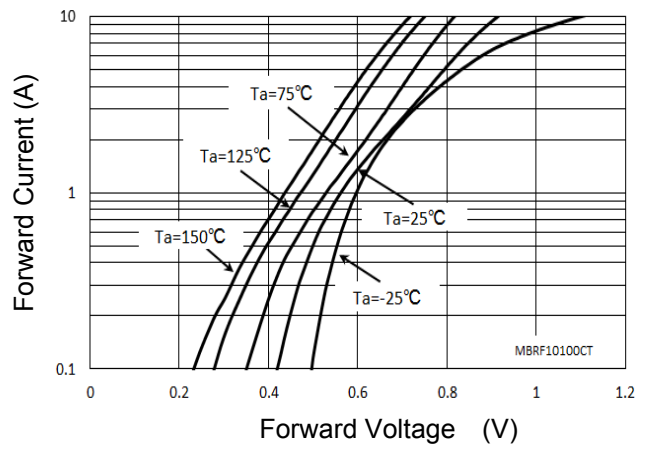

Fig 8. Thermal Resistance Curve

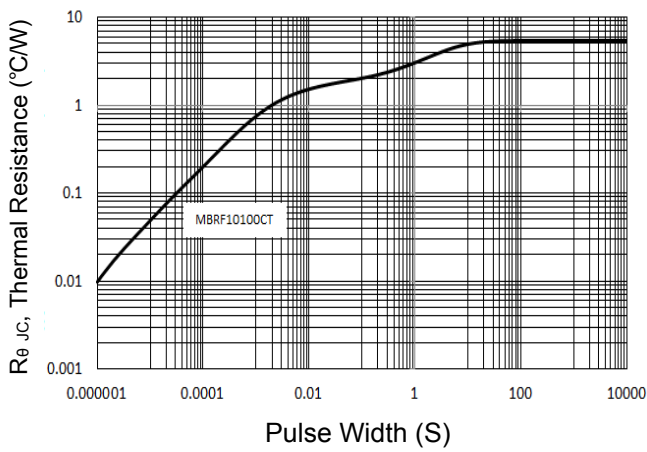
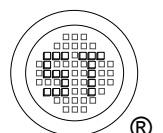
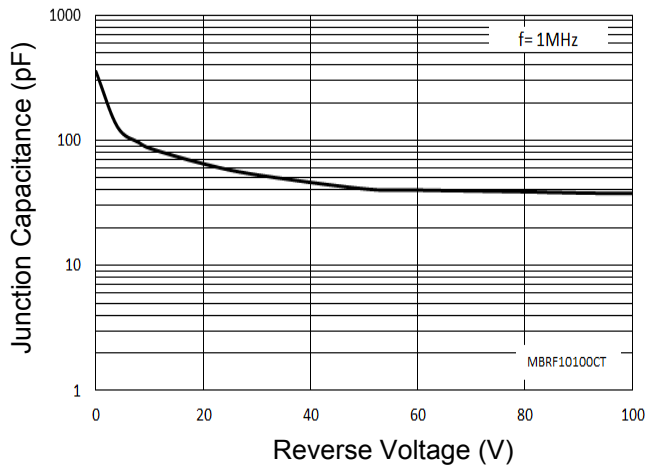

Fig 9. Junction Capacitance



MBRF1040CT THRU MBRF10200CT-HAF

Electrical Characteristics Curves

Fig 10. Reverse Characteristics Curve

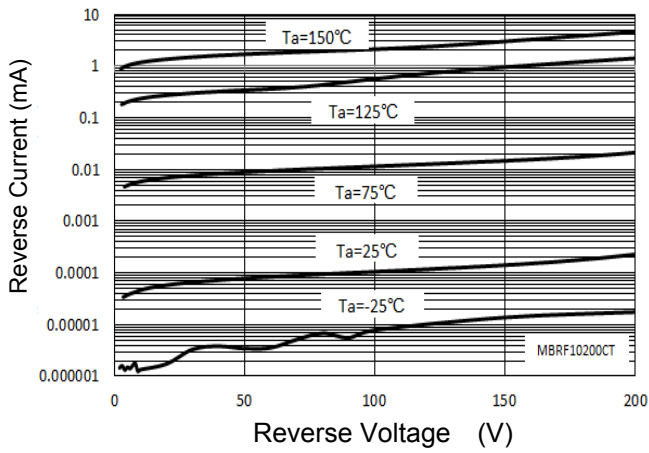

Fig 11. Forward Characteristics Curve

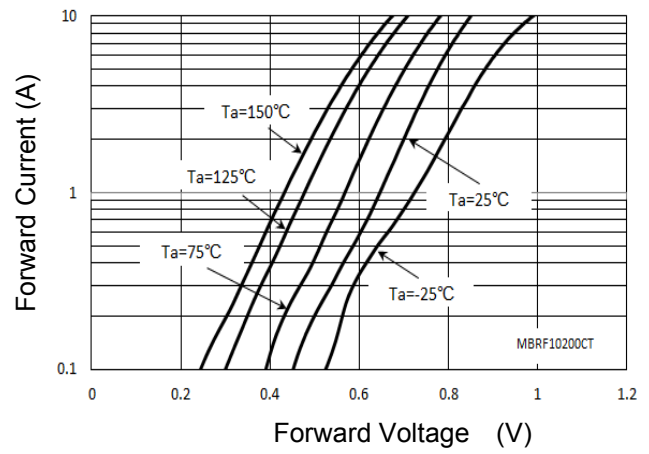

Fig 12. Thermal Resistance Curve

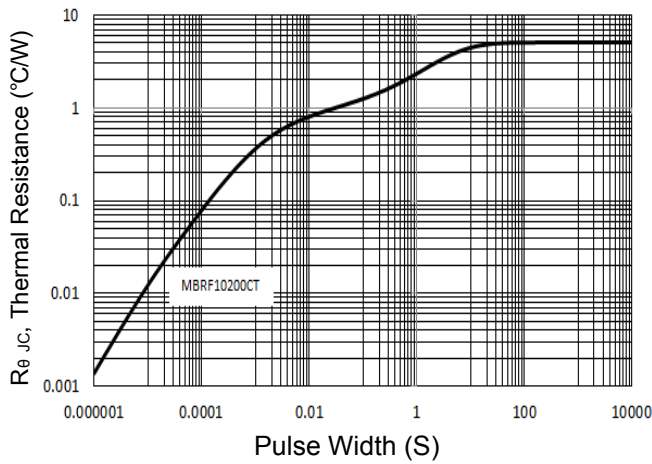
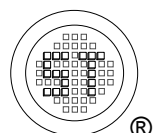
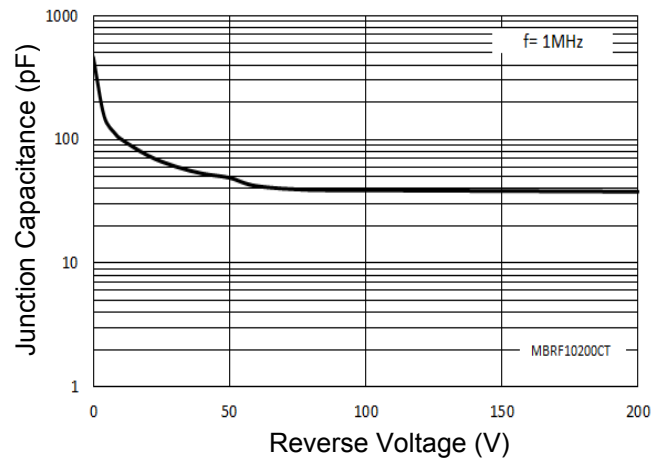

Fig 13. Junction Capacitance



MBRF1040CT THRU MBRF10200CT-HAF

Package Outline Dimensions (Units: mm)

TO-220F

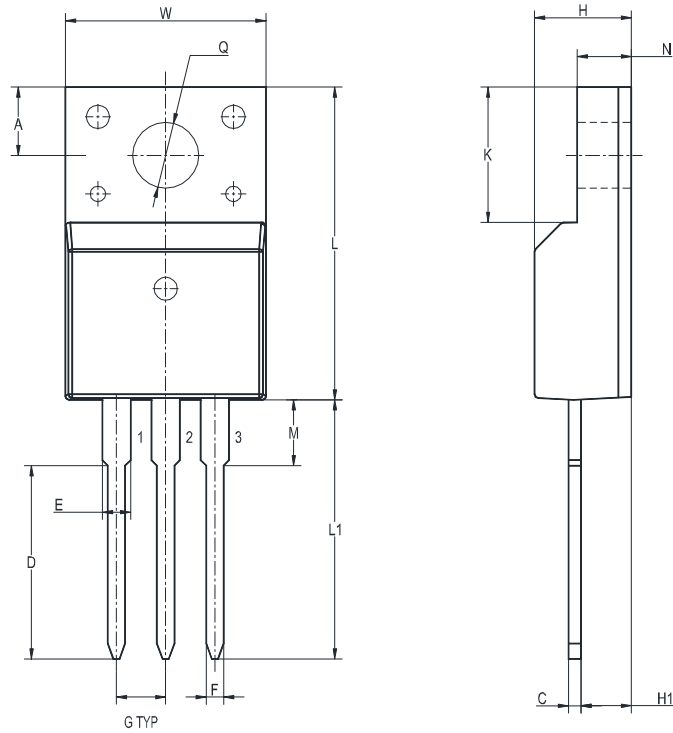

UNIT	A	C	D	E	F	G	W	H	H1	Q	L	L1	M	K	N
mm	3.5	0.7	10.3	1.5	0.9	2.54	10.5	4.9	2.9	3.4	16	13.5	3.5	6.7	2.8
	2.8	0.4	9.7	1.1	0.7	Typ.	9.5	4.5	2.5	2.9	15	12.5	2.9	6.2	2.3

Marking information

"*****" = Part No.

"*****" = Date Code Marking

Font type: Arial

