

Description

The P9382A is a highly-integrated single-chip wireless medium power transmitter/receiver IC (TRx). The device can be configured to receive or transmit an AC power signal through magnetic induction. When the device is configured as a wireless power transmitter, it uses on-chip full/half-bridge inverter, PWM generator, modulator/demodulator for communication and micro controller to produce an AC power signal to drive external L-C tank. As a receiver, the device receives an AC power signal from a wireless transmitter and converts it into rectified output voltage, which can be used to power devices or supply the charger input in mobile applications. The P9382A integrates a high-efficiency Synchronous Full Bridge Rectifier and control circuitry to modulate the load to send message packets to the Transmitter (Tx) to optimize power delivery.

The P9382A feature Multiple-time programmable (MTP) non-volatile memory to easily update control firmware and device functions.

The device includes over-temperature and voltage protection. Fault conditions associated with power transfer are managed by an industry-leading 32-bit ARM® Cortex®-M0 processor offering high level of programmability while consuming extremely low standby power to minimize power losses and heat generation. The processor can also control GPIOs to indicate operating and fault modes. The P9382A is available in an ultra-small 53-DSBGA package.

Typical Applications

- Wireless power Rx, Tx, TRx solution for mobile applications
- Mobile phones
- Notebooks and tablets
- Water or dust proof portable devices
- Smart home and IoT devices

Features

- Single-chip medium power wireless solution
- Multiple-time programmable (MTP) non-volatile memory
- WPC 1.2.4 compatible
- Delivers up to 20W as a receiver
- TRx mode with up to 6W Tx capability
- Embedded 32-bit ARM® Cortex®-M0 processor
- Reliable over voltage clamping
- Best in class EMI
- Proprietary Rx-to-Tx modulation/demodulation for two-way communication
- High-performance LDO
- Tx-to-Rx (backchannel) communication
- Supports proprietary mode magnetic induction wireless power solutions
- Supports I2C 400kHz standard interface and GPIOs
- Package:
 - 6 × 9 ball array, 2.80 × 4.0mm, 53-DSBGA package with 0.4mm ball pitch

Typical Applications Diagram

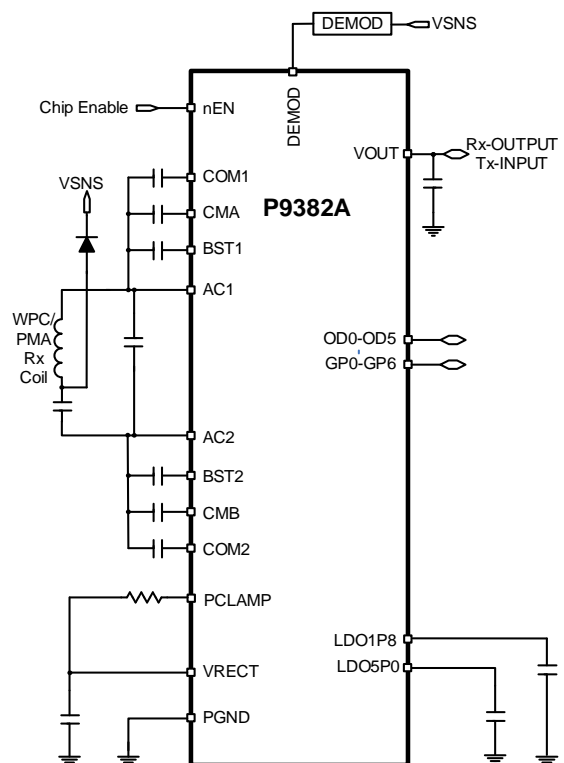

1. Package Outline Drawings

The package outline drawings are appended at the end of this document and are accessible from the link below. The package information is the most current data available.

www.idt.com/document/psc/53-dsbg-a-package-outline-drawing-2800-x-4010-x-0600-mm-body-040-mm-pitch-ahg53d1

2. Marking Diagram

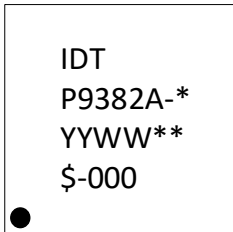

1. The IDT Company Logo
2. The part number.
3. "YYWW" is the last 2 digits of the year and week that the part was assembled. "***" denotes sequential lot number.
4. "\$" denotes assembly mark code. "000" denotes dash code.

3. Ordering Information

Orderable Part Number	Package	MSL Rating	Shipping Packaging	Ambient Temperature
P9382A-0*AHG18	2.80 × 4.00 × 0.4 mm pitch, 53-DSBGA	MSL 1	Tape and Reel	-40° to +85°C

* Note: This field is a custom value that is specific to each customer application. Please contact your local sales team for your particular value for this field.

4. Revision History

Revision Date	Description of Change
July 17, 2019	Initial release.



Corporate Headquarters
6024 Silver Creek Valley Road
San Jose, CA 95138
www.IDT.com

Sales
1-800-345-7015 or 408-284-8200
Fax: 408-284-2775
www.IDT.com/go/sales

Tech Support
www.IDT.com/go/support

DISCLAIMER Integrated Device Technology, Inc. (IDT) and its affiliated companies (herein referred to as "IDT") reserve the right to modify the products and/or specifications described herein at any time, without notice, at IDT's sole discretion. Performance specifications and operating parameters of the described products are determined in an independent state and are not guaranteed to perform the same way when installed in customer products. The information contained herein is provided without representation or warranty of any kind, whether express or implied, including, but not limited to, the suitability of IDT's products for any particular purpose, an implied warranty of merchantability, or non-infringement of the intellectual property rights of others. This document is presented only as a guide and does not convey any license under intellectual property rights of IDT or any third parties.

IDT's products are not intended for use in applications involving extreme environmental conditions or in life support systems or similar devices where the failure or malfunction of an IDT product can be reasonably expected to significantly affect the health or safety of users. Anyone using an IDT product in such a manner does so at their own risk, absent an express, written agreement by IDT.

Integrated Device Technology, IDT and the IDT logo are trademarks or registered trademarks of IDT and its subsidiaries in the United States and other countries. Other trademarks used herein are the property of IDT or their respective third party owners. For datasheet type definitions and a glossary of common terms, visit www.idt.com/go/glossary. All contents of this document are copyright of Integrated Device Technology, Inc. All rights reserved.

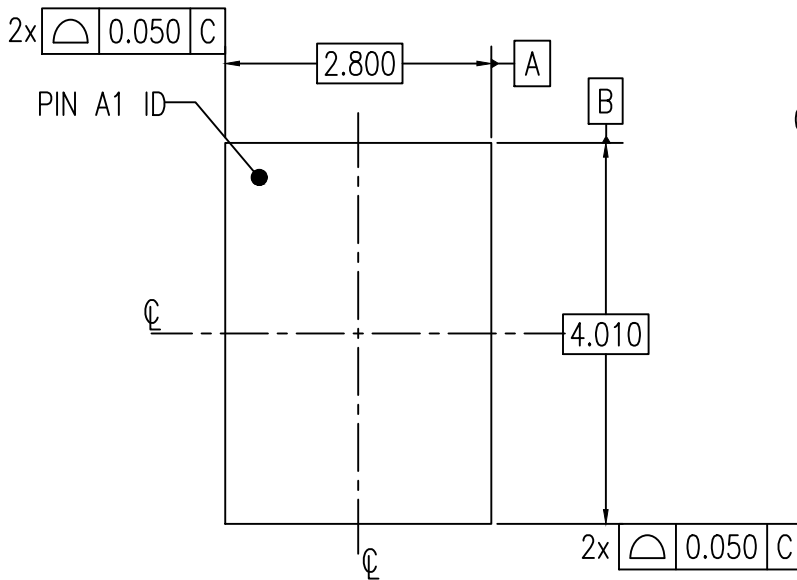

TOP VIEW

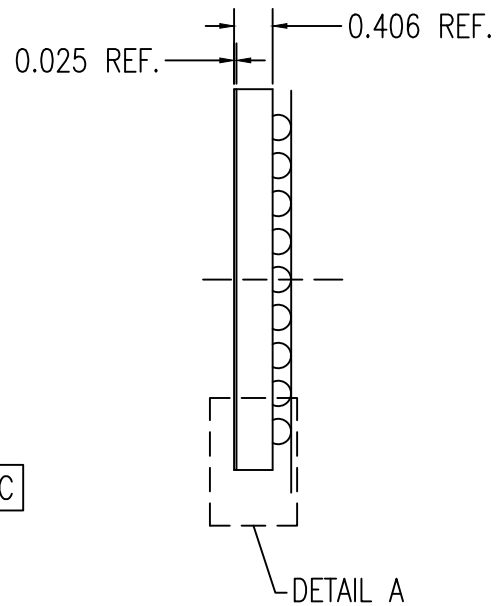

DETAIL A

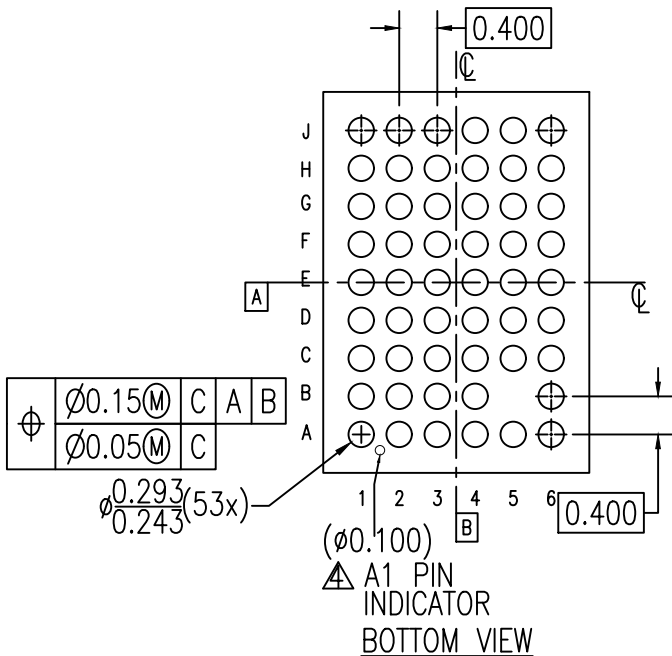

BOTTOM VIEW

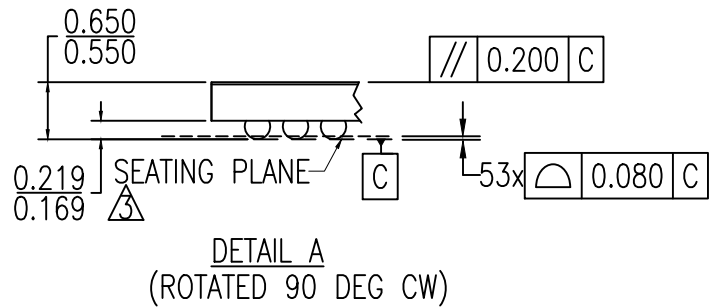

DETAIL A
(ROTATED 90 DEG CW)

NOTES:

1. ALL DIMENSIONS AND TOLERANCES ARE PER ASME Y14.5M-1994.
2. ALL DIMENSIONS ARE IN MILLIMETERS.

③ SEATING PLANE AND PRIMARY DATUM -C- ARE DEFINED BY THE CONTACT POINTS OF THREE OR MORE SOLDER BALLS THAT SUPPORT THE DEVICE WHEN PLACED ON A TOP OF A PLANAR SURFACE.

④ BOTTOM PIN#1 INDICATOR OPTIONAL.

5. BALL SIZE BEFORE REFLOW IS 0.25mm.

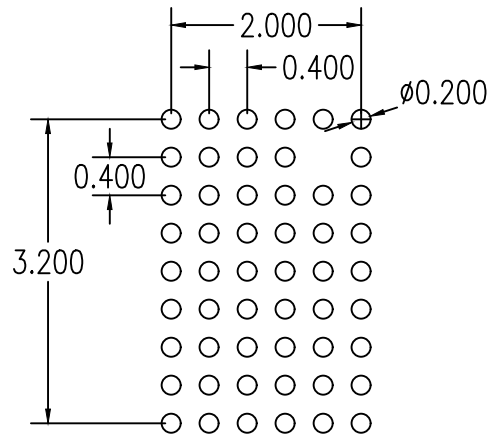

RECOMMENDED LAND PATTERN DIMENSION

NOTE:

1. ALL DIMENSIONS ARE IN MM, ANGLES IN DEGREES.
2. TOP DOWN VIEW, AS VIEW ON PCB.
3. NSMD LAND PATTERN ASSUMED.
4. LAND PATTERN RECOMMENDATION AS PER IPC-7351
GENERIC REQUIREMENT FOR SURFACE MOUNT DESIGN AND LAND PATTERN.

Package Revision History		
Date Created	Rev No.	Description
Jan 31, 2019	Rev 00	Initial Release