

# 18V PWM Fan Motor Driver

## DESCRIPTION

EUM6861/C is a fan motor driver for the single coil brushless DC motor. With its high efficient direct PWM control mode, EUM6861/C controls the speed of brushless DC motor with a built in HALL IC interface. EUM6861/C is suitable to drive variable speed motors for personal computer's power supply radiation fans and CPU coolers.

EUM6861/C integrates PWM fan speed control, minimum speed mode, soft start, fan tachometer, lock protection, auto restart and Hall Bias functions. PWM mode controls fan speed in low noise and low vibration ways by adjusting RCTL voltage. EUM6861/C can set minimum fan speed by presetting RMIN voltage. With soft start function, EUM6861/C can drive motor from slow speed to fast speed in a settable time by setting the external capacitor between SS and GND. If a fan motor is stalled by the external force or obstacles, overdrive current may incur coil overheat and burning. To prevent motor from overheating, the lock protection circuit shuts down the internal power devices for a few seconds after the motor lock is detected. Then the auto restart circuit resumes to power up the internal power devices. If the lock persists, EUM6861/C shuts off power devices for a few seconds. The lock protection delay time is externally programmable by a capacitor. EUM6861/C has built in motor rotation speed feedback (FG) output, motor rotation detection (RD) output and Hall sensor bias output.

## FEATURES

- Built in 18V Full-wave Motor Driver for Fan Motor
- Built in Input Surge Protection, No Zener Diode Need
- External Programmable Soft Start and Soft Restart Function (EUM6861)
- Wide Input Range 3V~18V
- PWM Fan Speed Control
- Programmable Minimum Fan Speed
- Built in Soft Switching Function
- Built in Hall Bias
- Lock Protection and Auto Restart
- Fan Rotation Speed Feedback FG Output
- Fan Rotation Detection RD Output
- Thermal Shutdown Protection
- Available in TSSOP-16 Package
- RoHS Compliant and 100% Lead (Pb)-Free Halogen-Free

## APPLICATIONS

- Personal Computer's Power Supply Radiation Fans and CPU Coolers

## Application Circuit

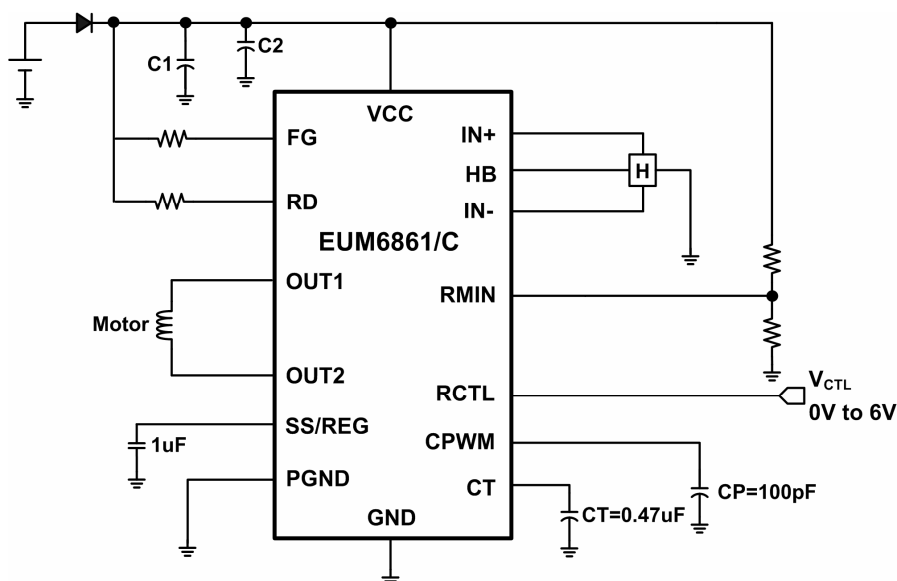

Figure 1. Typical Application Circuit

## Application Circuit (continued)

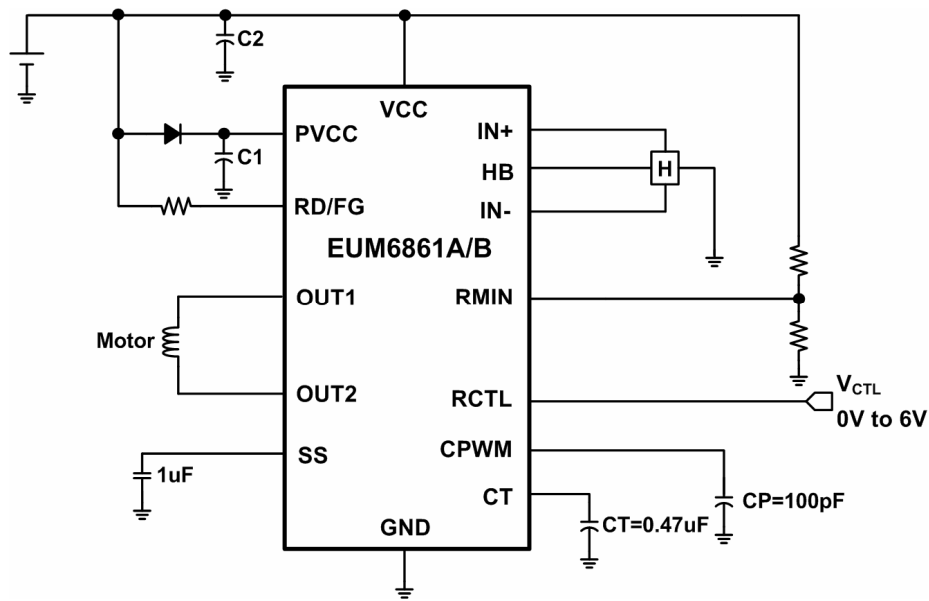

Figure 2. TDFN-14 Typical Application Circuit

## Functional Block Diagram

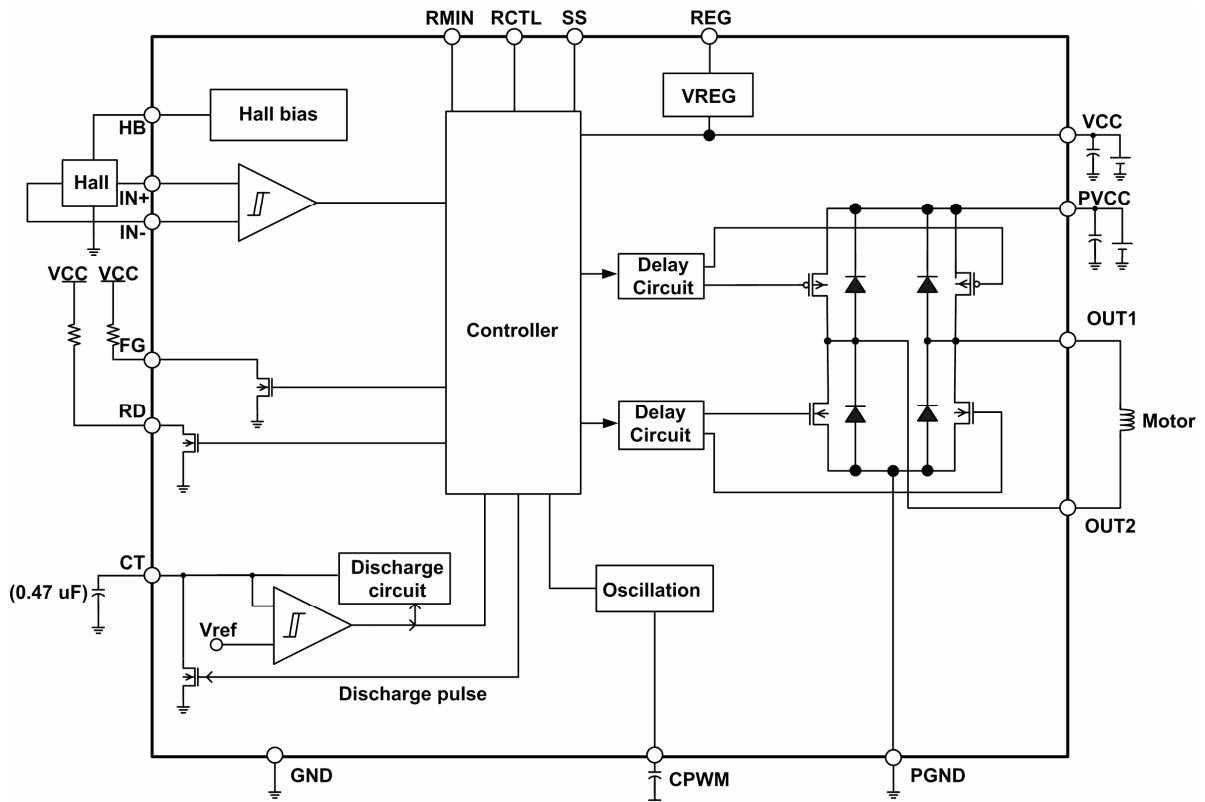

Figure 3. Functional Block Diagram