

2SB834 TRANSISTOR (PNP)

FEATURES

- Low Collector -Emitter Saturation Voltage
 $V_{CE(sat)}=1.0V(Max) @ I_C=-3A, I_B=-0.3A$
- DC current Gain
 $h_{FE} =60-200 @ I_C=0.5A$
- Complementary to NPN 2SD880

MAXIMUM RATINGS (T_a=25°C unless otherwise noted)

Symbol	Parameter	Value	Unit
V _{CB0}	Collector- Base Voltage	-60	V
V _{CEO}	Collector-Emitter Voltage	-60	V
V _{EBO}	Emitter-Base Voltage	-7	V
I _C	Collector Current -Continuous	-3	A
P _C	Collector Power Dissipation	1.5	W
T _J , T _{stg}	Operation Junction and Storage Temperature Range	-55-150	°C

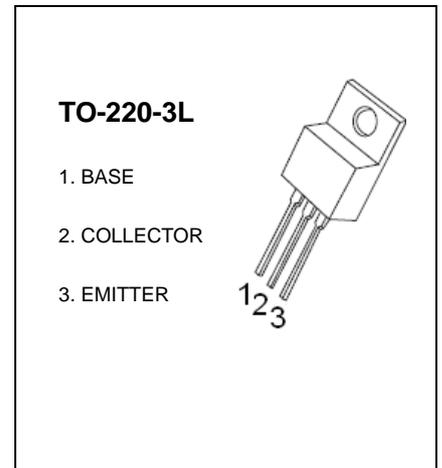

ELECTRICAL CHARACTERISTICS (T_a=25°C unless otherwise specified)

Parameter	Symbol	Test conditions	Min	Typ	Max	Unit
Collector-base breakdown voltage	V _{(BR)CBO}	I _C =-1mA, I _E =0	-60			V
Collector-emitter breakdown voltage	V _{(BR)CEO}	I _C =-50mA, I _B =0	-60			V
Emitter-base breakdown voltage	V _{(BR)EBO}	I _E =-1mA, I _C =0	-7			V
Collector cut-off current	I _{CBO}	V _{CB} =-60V, I _E =0			-100	μA
Emitter cut-off current	I _{EBO}	V _{EB} =-7V, I _C =0			-100	μA
DC current gain	h _{FE(1)*}	V _{CE} =-5V, I _C =-500mA	60		200	
	h _{FE(2)*}	V _{CE} =-5V, I _C =-3A	20			
Collector-emitter saturation voltage	V _{CE(sat)*}	I _C =-3A, I _B =-0.3A			-1	V
Base-emitter voltage	V _{BE*}	V _{CE} =-5V, I _C =-500mA			-1	V
Transition frequency	f _T	V _{CE} =-5V, I _C =-500mA, f=1MHz		9		MHz
Turn-on Time	t _{on}	V _{CC} =-30V, I _C =-2A, I _{B1} =I _{B2} =-0.2A		0.4		μs
Storage Time	t _{stg}			1.7		μs
Turn-off Time	t _{off}			0.5		μs

*Pulse test.

CLASSIFICATION OF h_{FE(1)}

Rank	O	Y
Range	60-120	100-200

Typical Characteristics

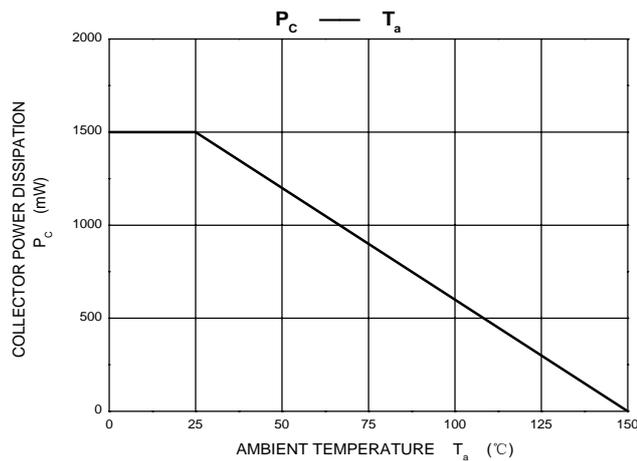
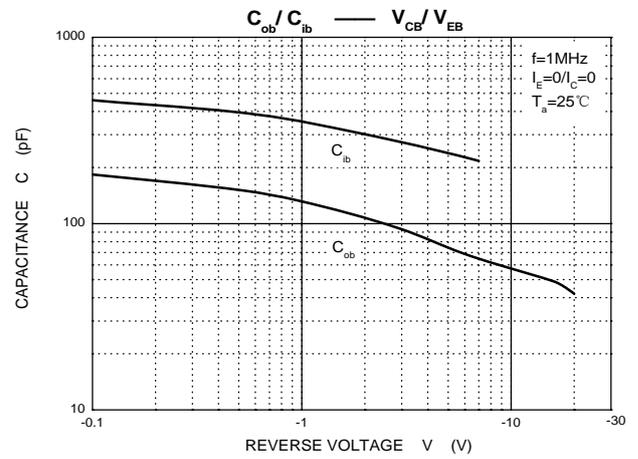
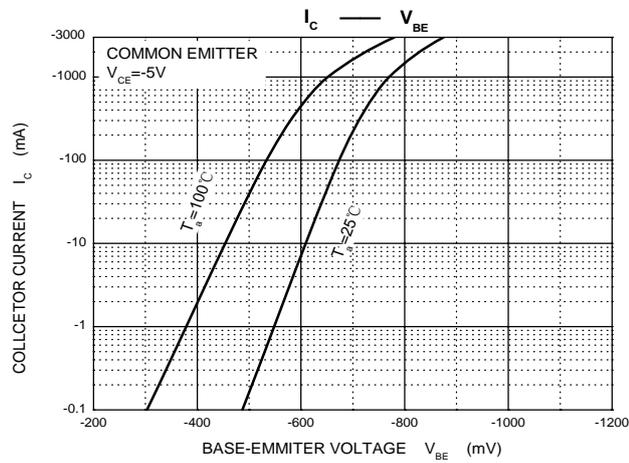
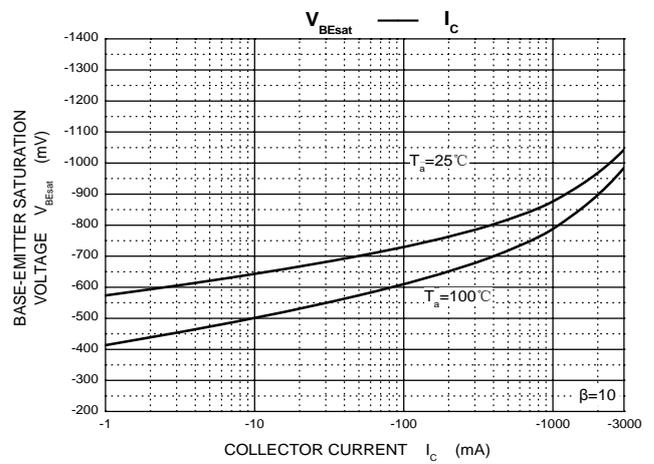
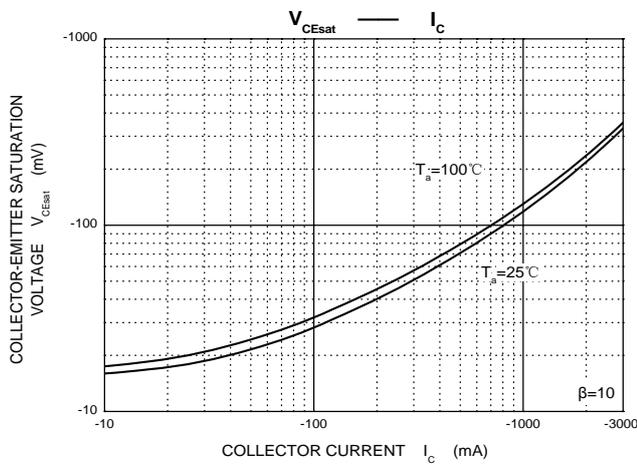
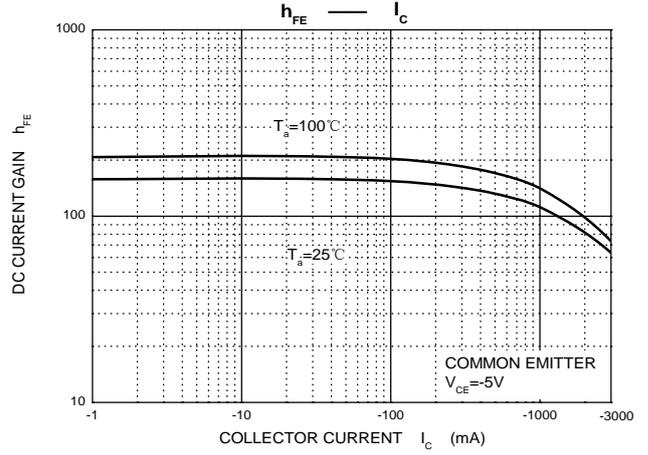
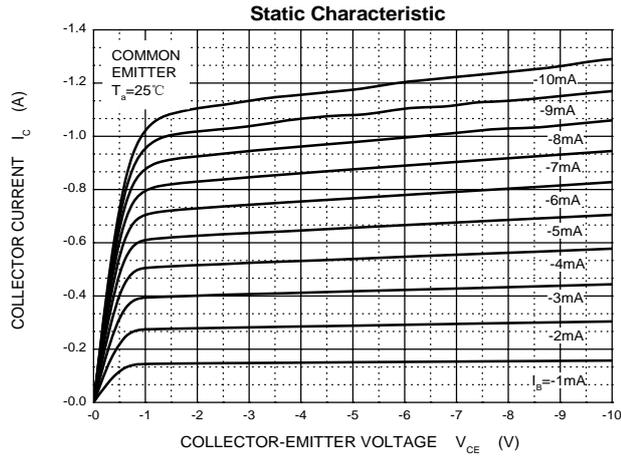

TO-220-3L Package Outline Dimensions

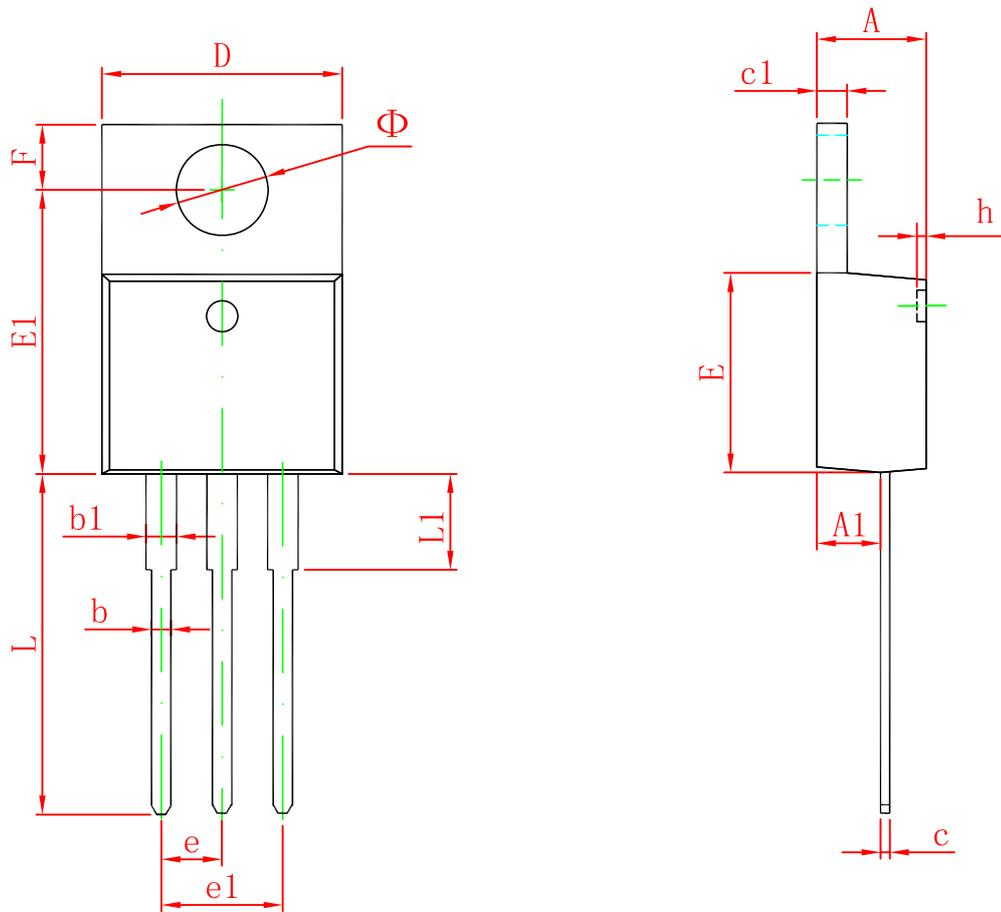

Symbol	Dimensions In Millimeters		Dimensions In Inches	
	Min	Max	Min	Max
A	4.470	4.670	0.176	0.184
A1	2.520	2.820	0.099	0.111
b	0.710	0.910	0.028	0.036
b1	1.170	1.370	0.046	0.054
c	0.310	0.530	0.012	0.021
c1	1.170	1.370	0.046	0.054
D	10.010	10.310	0.394	0.406
E	8.500	8.900	0.335	0.350
E1	12.060	12.460	0.475	0.491
e	2.540 TYP		0.100 TYP	
e1	4.980	5.180	0.196	0.204
F	2.590	2.890	0.102	0.114
h	0.000	0.300	0.000	0.012
L	13.400	13.800	0.528	0.543
L1	3.560	3.960	0.140	0.156
Φ	3.735	3.935	0.147	0.155