

Transistors

2SC1674

TV PIF AMPLIFIER, FM TUNER RF AMPLIFIER, MIXER, OSCILLATOR

- High Current-Gain-Bandwidth Product $f_T = 600\text{MHz}$ (Typ)
- High Power Gain $G_{pe} = 22\text{dB}$ at $f = 100\text{MHz}$

ABSOLUTE MAXIMUM RATINGS ($T_a = 25^\circ\text{C}$)

Characteristic	Symbol	Rating	Unit
Collector-Base Voltage	V_{CBO}	30	V
Collector-Emitter Voltage	V_{CEO}	20	V
Emitter-Base Voltage	V_{EBO}	4	V
Collector Current	I_C	20	mA
Collector Dissipation	P_C	250	mW
Junction Temperature	T_j	150	$^\circ\text{C}$
Storage Temperature	T_{stg}	-55 ~ 150	$^\circ\text{C}$

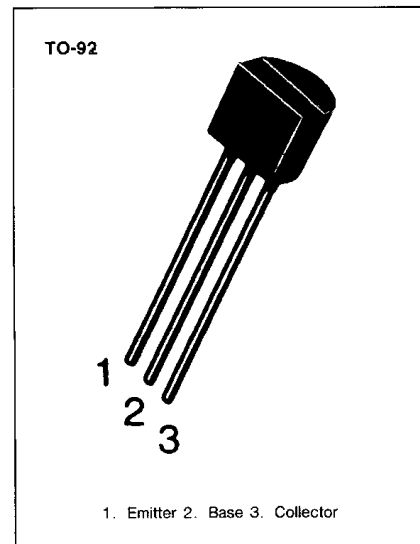

ELECTRICAL CHARACTERISTICS ($T_a = 25^\circ\text{C}$)

Characteristic	Symbol	Test Conditions	Min	Typ	Max	Unit
Collector-Base Breakdown Voltage	BV_{CBO}	$I_C = 10\mu\text{A}, I_E = 0$	30			V
Collector-Emitter Breakdown Voltage	BV_{CEO}	$I_C = 5\text{mA}, I_B = 0$	20			V
Emitter-Base Breakdown Voltage	BV_{EBO}	$I_E = 10\mu\text{A}, I_C = 0$	4			V
Collector Cut-off Current	I_{CBO}	$V_{CB} = 30\text{V}, I_E = 0$			0.1	μA
Emitter Cut-off Current	I_{EBO}	$V_{EB} = 4\text{V}, I_C = 0$			0.1	μA
DC Current Gain	h_{FE}	$V_{CE} = 6\text{V}, I_C = 1\text{mA}$	40		240	
Base-Emitter On Voltage	$V_{BE}(\text{on})$	$V_{CE} = 6\text{V}, I_C = 1\text{mA}$		0.72		V
Collector-Emitter Saturation Voltage	$V_{CE}(\text{sat})$	$I_C = 10\text{mA}, I_B = 1\text{mA}$		0.1	0.3	V
Current-Gain-Bandwidth Product	f_T	$V_{CE} = 6\text{V}, I_C = 1\text{mA}$	400	600		MHz
Output Capacitance	C_{ob}	$V_{CB} = 6\text{V}, I_E = 0$ $f = 1\text{MHz}$		1.2		pF
Collector-Base Time Constant	$C_c r_{bb'}$	$V_{CE} = 6\text{V}, I_E = 1\text{mA}$ $f = 31.9\text{MHz}$		12	15	ps
Common Source Noise Figure	NF	$V_{CE} = 6\text{V}, I_E = 1\text{mA}$ $R_S = 50\Omega, f = 100\text{MHz}$		3.0	5.0	dB
Power Gain	G_{pe}	$V_{CE} = 6\text{V}, I_E = 1\text{mA}$ $R_S = 50\Omega, f = 100\text{MHz}$ (Typ)	18	22		dB

h_{FE} CLASSIFICATION

Classification	R	O	Y
h_{FE}	40-80	70-140	120-240



STATIC CHARACTERISTIC

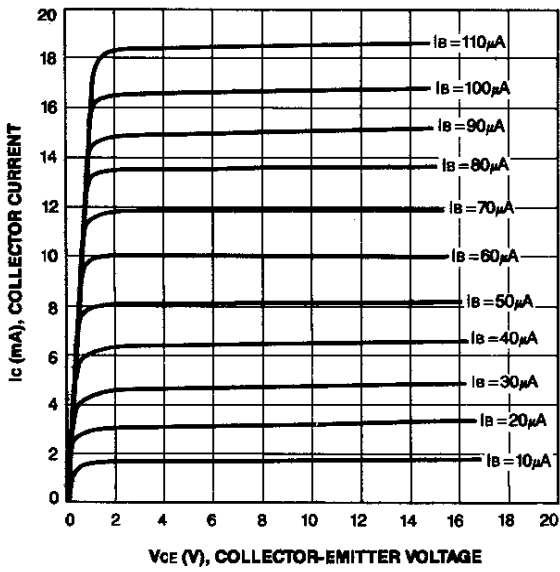

BASE-EMITTER ON VOLTAGE

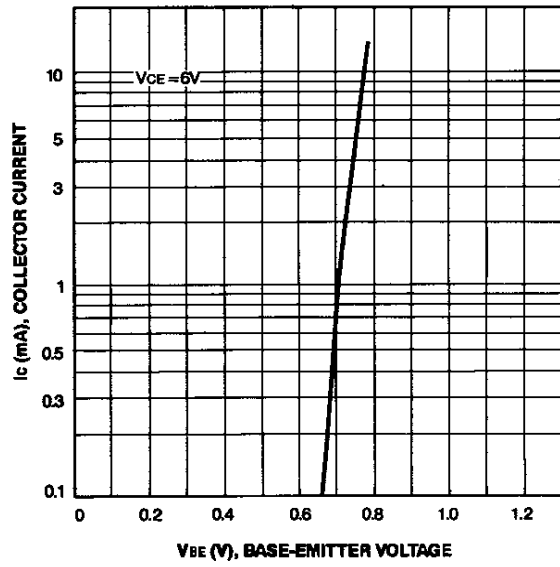

DC CURRENT GAIN

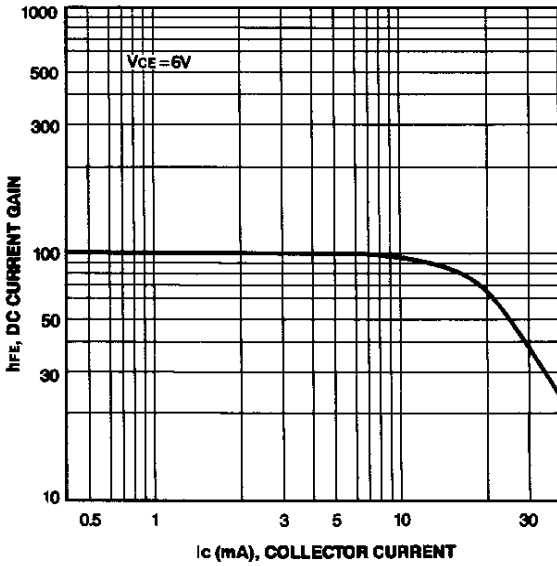

CURRENT GAIN-BANDWIDTH PRODUCT

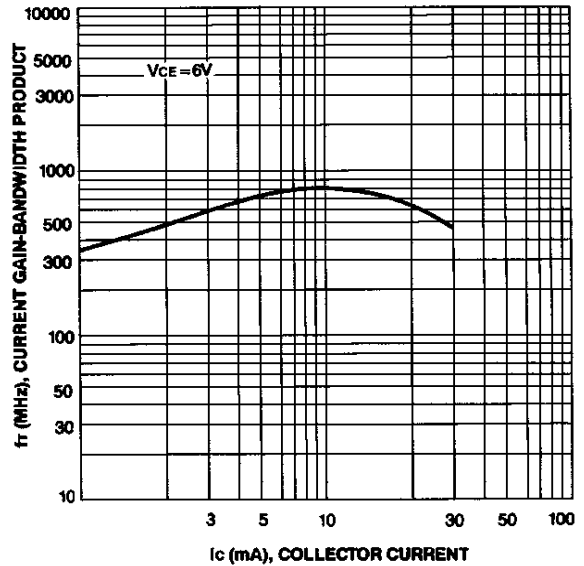

**BASE-EMITTER SATURATION VOLTAGE
COLLECTOR-EMITTER SATURATION VOLTAGE**

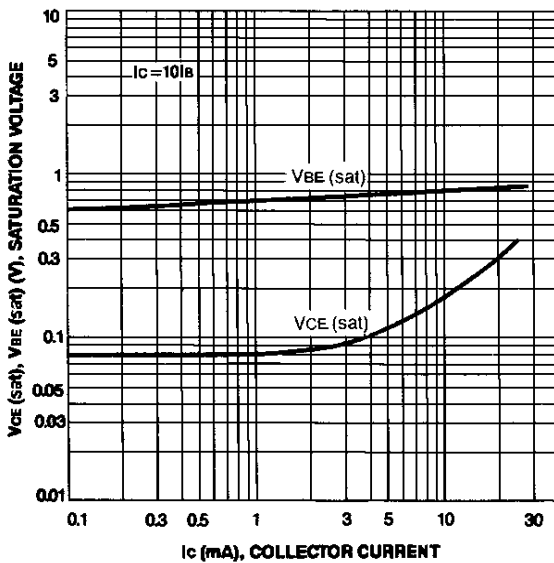

COLLECTOR OUTPUT CAPACITANCE

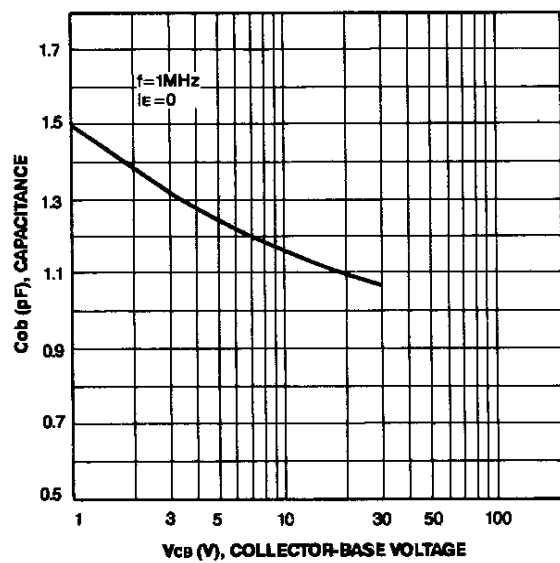

**INPUT ADMITTANCE (y_{ie})
vs. COLLECTOR CURRENT**

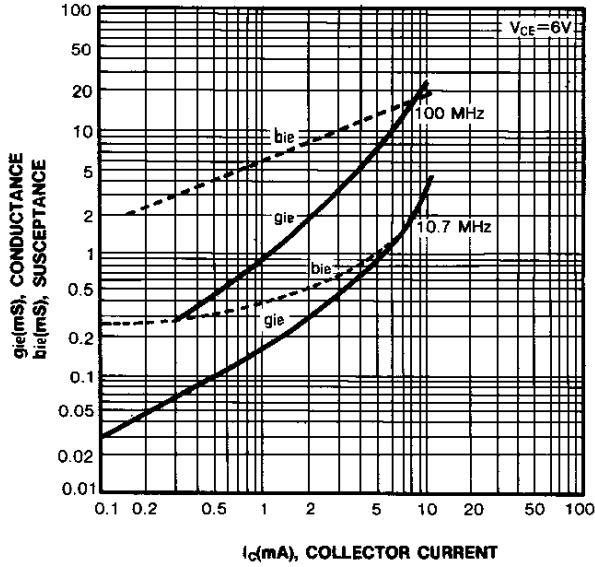

**FORWARD TRANSFER ADMITTANCE (y_{fe})
vs. COLLECTOR CURRENT**

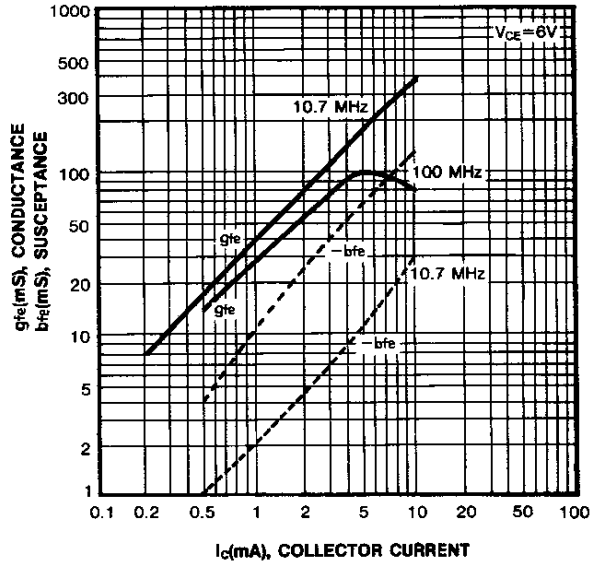

**REVERSE TRANSFER ADMITTANCE (y_{re})
vs. COLLECTOR CURRENT**

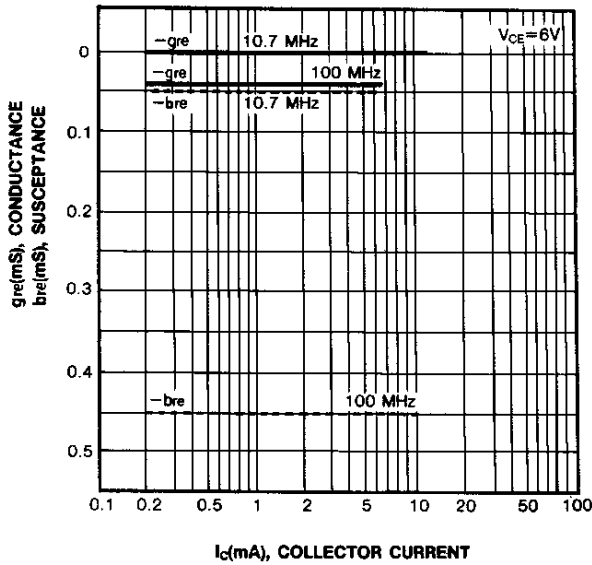

**OUTPUT ADMITTANCE (y_{oe})
vs. COLLECTOR CURRENT**

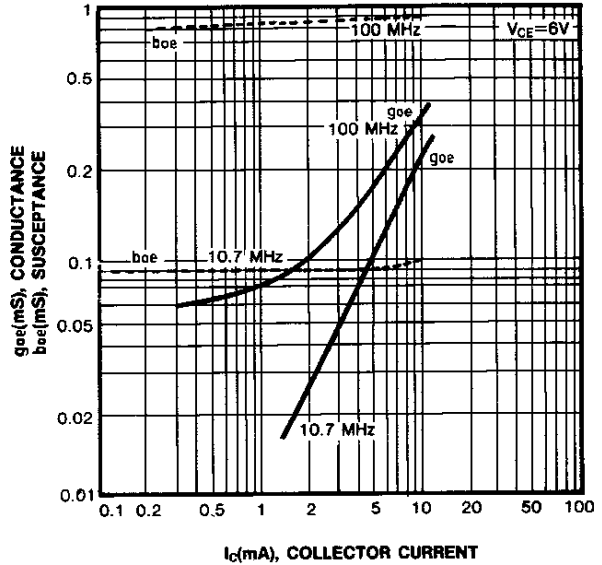

INPUT ADMITTANCE (y_{ib}) vs. COLLECTOR CURRENT

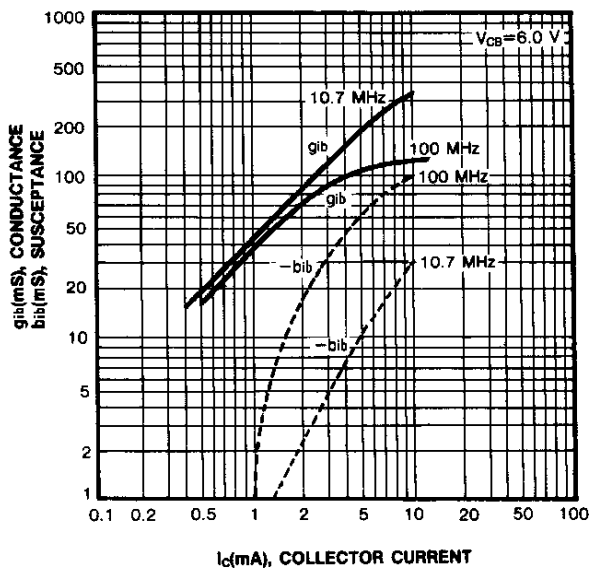

**FORWARD TRANSFER ADMITTANCE (y_{fb})
vs. COLLECTOR CURRENT**

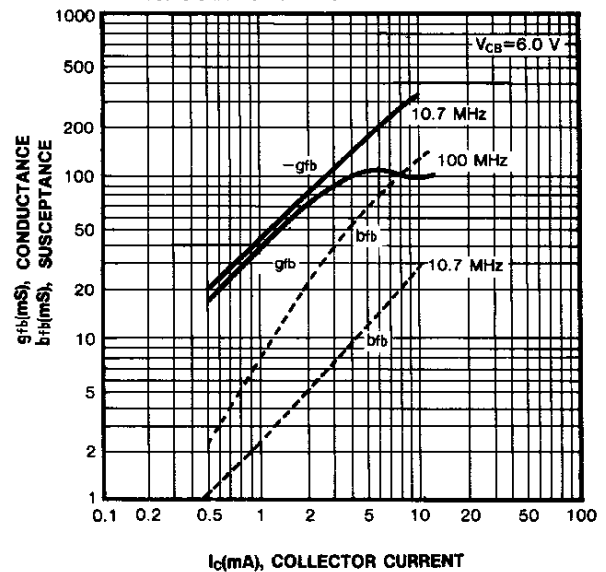

REVERSE TRANSFER ADMITTANCE (y_{rb}) vs. COLLECTOR CURRENT

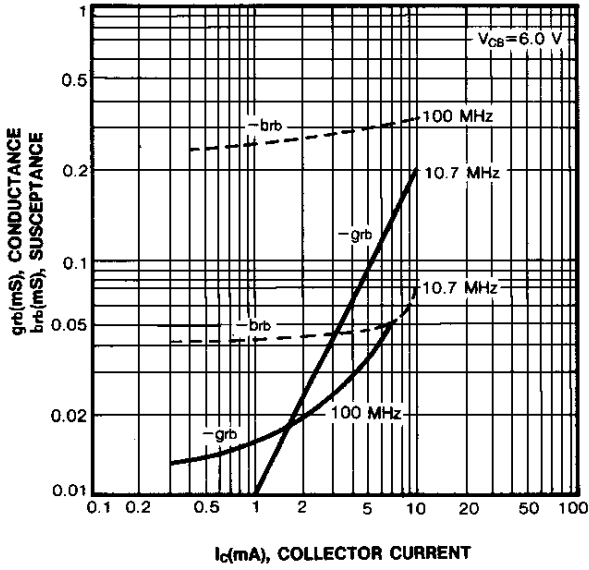

REVER TRANSFER ADMITTANCE (y_{re}) vs. FREQUENCY

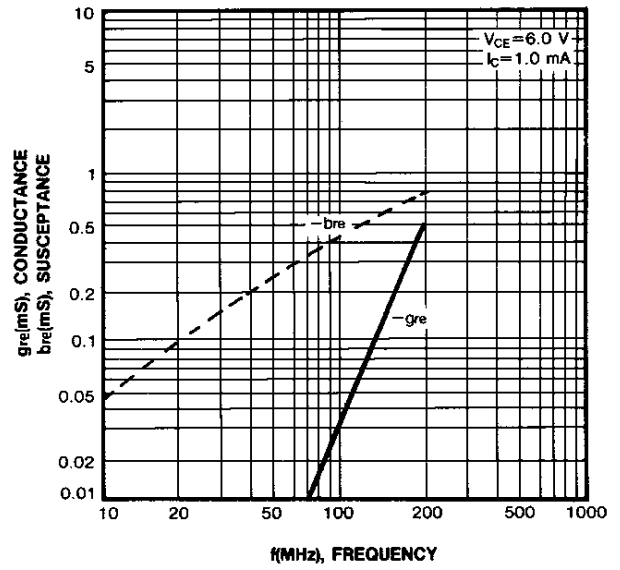

FORWARD TRANSFER ADMITTANCE (y_{fe}) vs. FREQUENCY

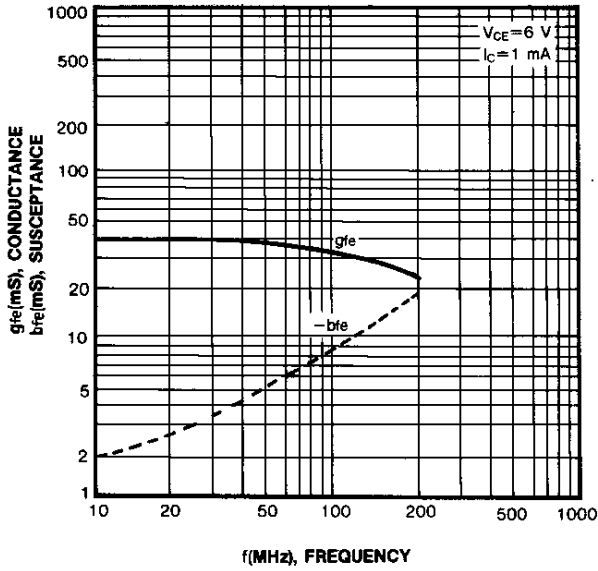

OUTPUT ADMITTANCE (y_{oe}) vs. FREQUENCY

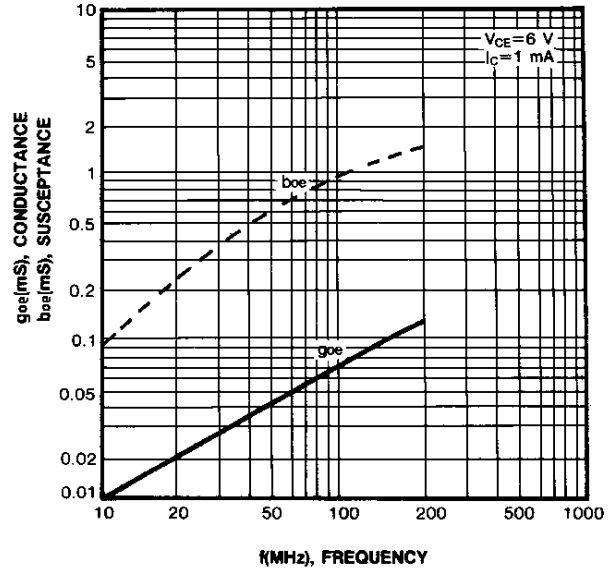

POWER GAIN AND NOISE FIGURE vs. EMITTER CURRENT

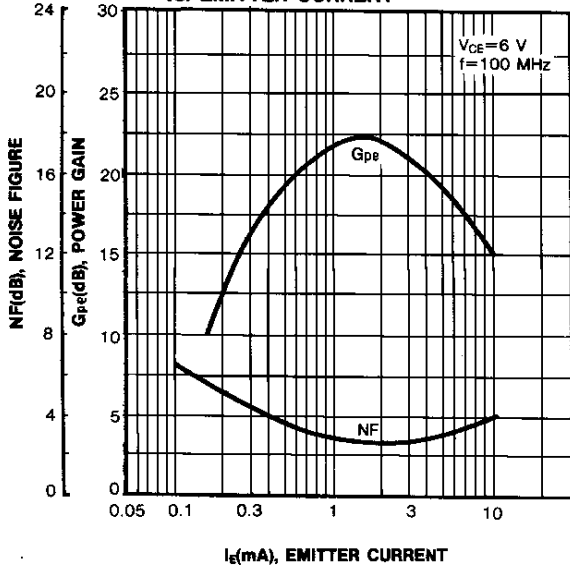

INPUT ADMITTANCE (y_{ie}) vs. FREQUENCY

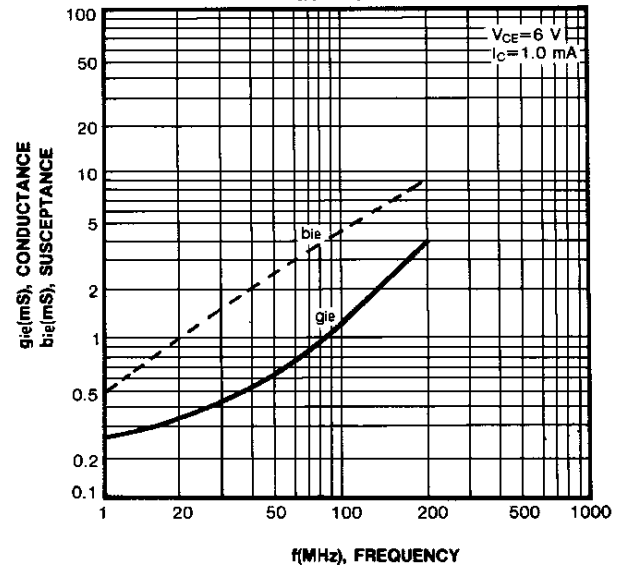

100MHz G_{pe} , NF TEST CIRCUIT

