

**SURFACE MOUNT SUPERFAST RECOVERY RECTIFIERS***Forward Current-3.0A**Reverse Voltage-50V to 600V***FEATURES**

- ◆ For surface mount applications
- ◆ Glass passivated chip junction
- ◆ Low profile package
- ◆ Superfast reverse recovery time
- ◆ Lead free in comply with EU RoHS2011/65/EU directives

MECHANICAL DATA

- ◆ Case: SMBF molded plastic body
- ◆ Terminals: Solderable per MIL-STD-750 , Method2026
- ◆ Weight: Approximated 0.057 grams

PINNING

PIN	DESCRIPTION
1	Cathode
2	Anode

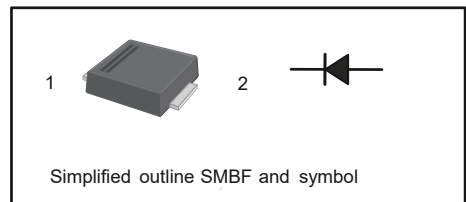
**MAXIMUM RATINGS AND ELECTRICAL CHARACTERISTICS**

Ratings at 25°C ambient temperature unless otherwise specified.

Single phase half-wave 60 Hz, resistive or inductive load, for capacitive load current derating by 20 %.

PARAMETER	SYMBOL	ES3ABF -PJ	ES3BBF -PJ	ES3CBF -PJ	ES3DBF -PJ	ES3EBF -PJ	ES3GBF -PJ	ES3JBF -PJ	UNIT
Maximum Repetitive Peak Reverse Voltage	V_{RRM}	50	100	150	200	300	400	600	V
Maximum RMS Voltage	V_{RMS}	35	70	105	140	210	280	420	V
Maximum DC Blocking Voltage	V_{DC}	50	100	150	200	300	400	600	V
Maximum Average Forward Rectified Current at $T_C=125^\circ\text{C}$	$I_{F(AV)}$	3.0							A
Peak Forward Surge Current (Note1)	I_{FSM}	100							A
Maximum Forward Voltage at 3.0 A	V_F	1				1.25		1.68	V
Maximum DC Reverse Current at Rated DC Blocking Voltage at $T_A=25^\circ\text{C}$ $T_A=125^\circ\text{C}$	I_R	5 100							μA
Typical Junction Capacitance at $V_R=4\text{V}, f=1\text{MHz}$	C_J	35							pF
Maximum Reverse Recovery Time (Note2)	T_{rr}	35							nS
Typical Thermal Resistance(Note3)	$R_{\theta JA}$ $R_{\theta JC}$	45 15							$^\circ\text{C/W}$
Operating and Storage Temperature Range	T_J, T_{STG}	-55 to +150							$^\circ\text{C}$

Notes: 1. Measured at 8.3 ms single half sine wave superimposed on rated load (JEDEC Method).

2. Measured with $I_F=0.5\text{A}$, $I_R=1\text{A}$, $I_{rr}=0.25\text{A}$.

3. P.C.B. mounted with 2.0" X 2.0" (5 X 5 cm) copper pad areas.



RATINGS AND CHARACTERISTIC CURVES

Fig.1 Reverse Recovery Time Characteristic And Test Circuit Diagram

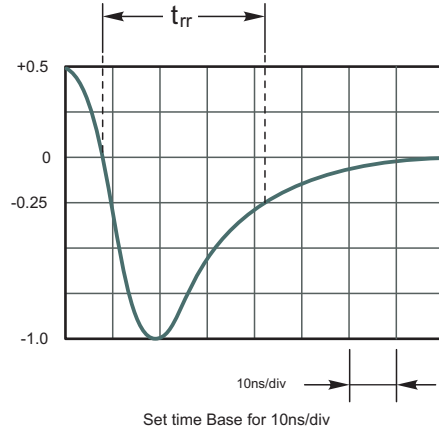
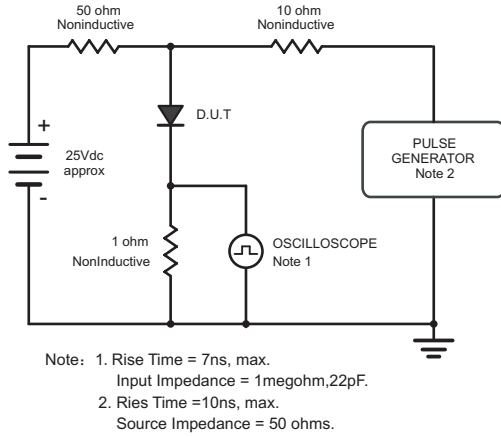

Fig.2 Maximum Average Forward Current Rating

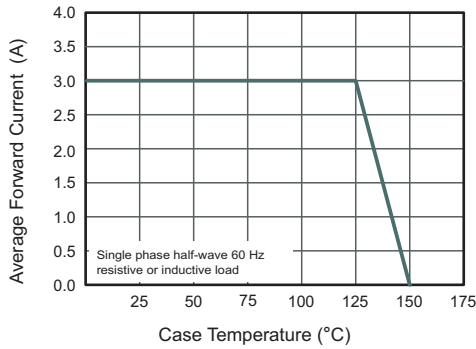

Fig.3 Typical Reverse Characteristics

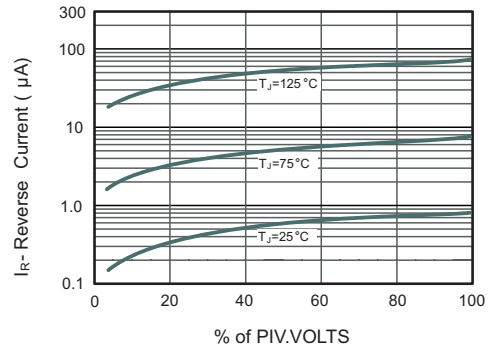

Fig.4 Typical Forward Characteristics

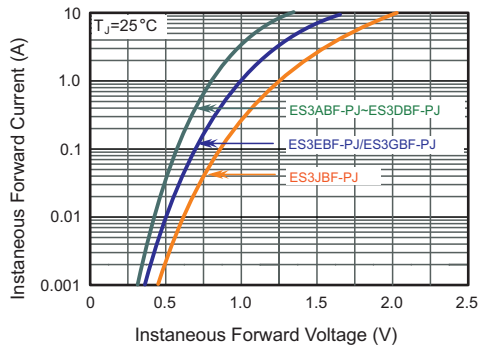

Fig.5 Typical Junction Capacitance

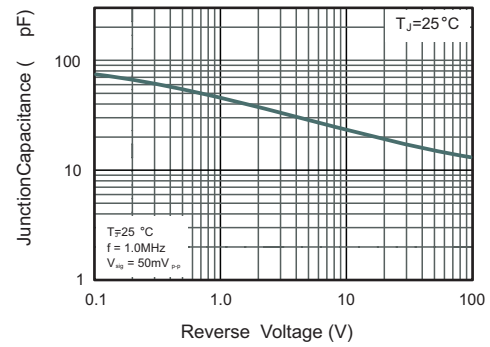
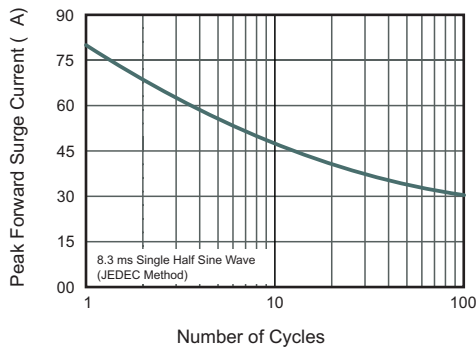
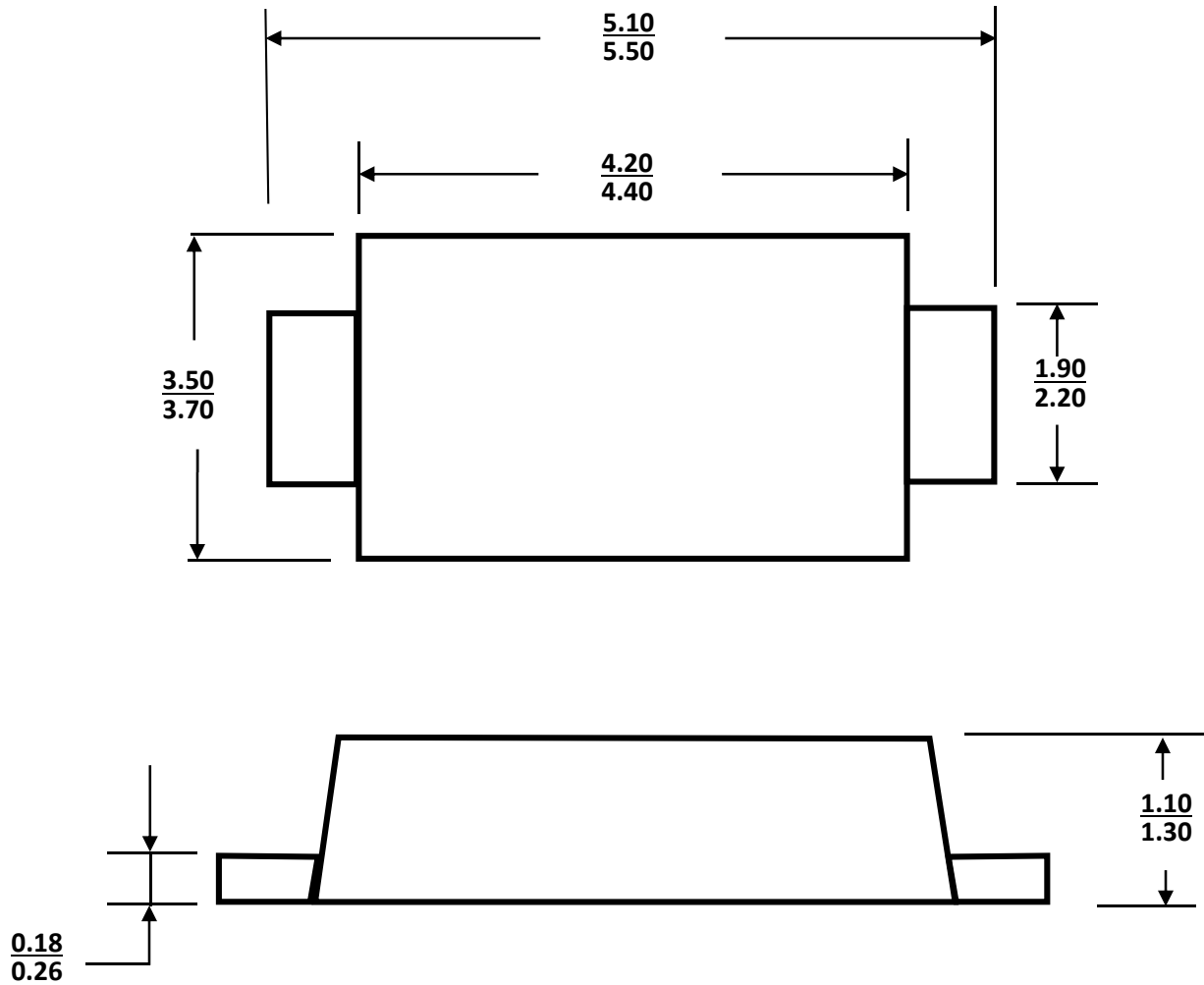

Fig.6 Maximum Non-Repetitive Peak Forward Surge Current



PACKAGE OUTLINE

SMBF



Dimensions in millimeters

ORDERING INFORMATION

Device	Package	Shipping
ES3ABF-PJ thru ES3JBF-PJ	SMBF	5,000/Tape & Reel (13 inches)