

Device Features

- Typical Isolation = 25.0 dB @ 3.5GHz
- Typical Insertion Loss = 0.6 dB @ 3.5GHz
- MSL 3 moisture rating
- Small Size and Low Profile
- Lead-free/RoHS-compliant SOT-26 Plastic Package



BD35XX(XX=Wafer number)

Product Description

BeRex's Divider BD3526 is designed for WCDMA, LTE band and 5G with low Insertion Loss and Isolation. This chip is fully passivated for enhanced performance and reliability and packaged in RoHS-compliant with SOT-26 surface mount package.

Typical Performance¹

Parameter	Min	Typical	Max	Unit
Frequency Range	2800		4200	MHz
Insertion Loss		0.6	0.8	dB
Isolation	16	25		dB
IRL(S11)		-25	-16	dB
ORL(S22/S33)		-25	-15	dB
Amplitude Balance		0.08	0.15	dB
Phase Balance		0.4	3.0	deg

*All specifications apply to the following test conditions,

1. Device performance _ measured on BeRex E/B at 25°C, 50ohm system.
2. Insertion Loss: Above 3.0dB.

Applications

- Base station Infrastructure
- Commercial/Industrial/Military wireless system
- 5G/LTE/WCDMA Wireless Infrastructure

Absolute Maximum Ratings

Parameter	Rating
Input Power	1.5W CW dBm
Storage Temperature	-55 to +155°C
Operating Temperature	-40 to +105°C

Operation of this device above any of these parameters may result in permanent damage.

Evaluation Board Drawing

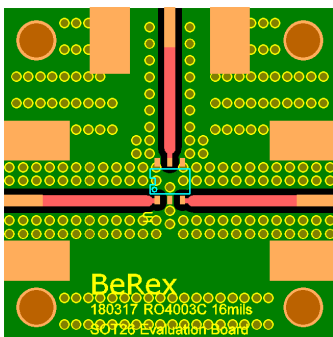

*RO4003C_0.4T

Function Block Diagram

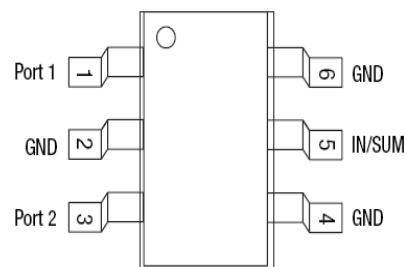

Pins 2,4 and 6 must be DC and RF grounded.

Typical Test Data

Parameters	Unit	WCDMA, LTE & 5G				
		2800	3200	3500	3800	4200
Frequency Range	MHz	2800	3200	3500	3800	4200
Insertion Loss	dB	0.62	0.63	0.59	0.63	0.82
Isolation	dB	15.7	23.7	38.0	22.4	16.5
IRL(S11)	dB	-17.0	-20.3	-26.1	-33.3	-16.8
ORL(S22,S33)	dB	-15.7	-20.1	-27.3	-33.3	-20.6
Phase Diff.	deg	0.39	0.33	0.38	0.60	0.54
Amplitude Balance	dB	0.10	0.08	0.05	0.05	0.08

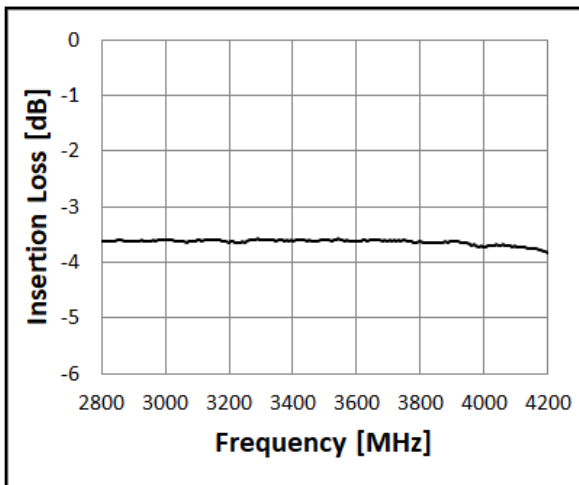
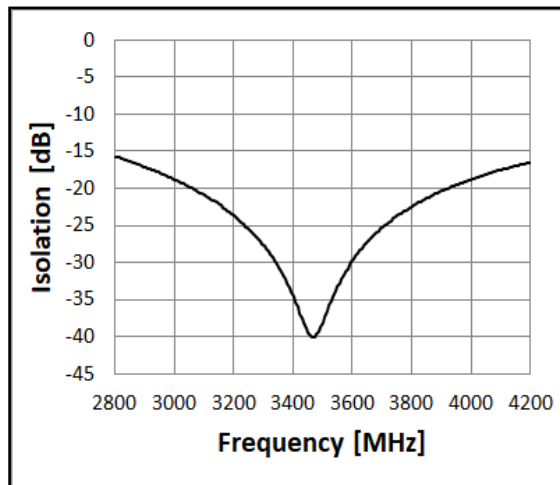
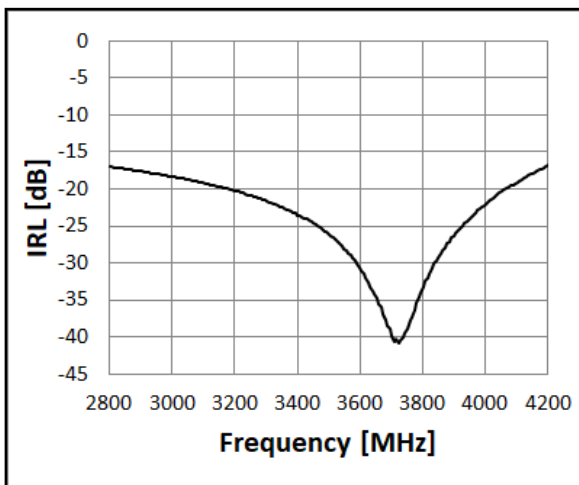
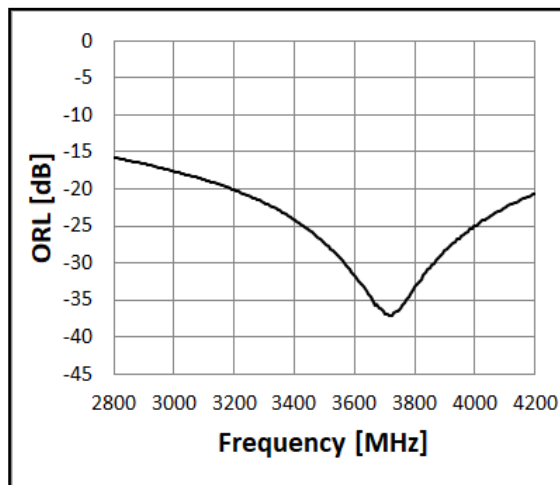
Insertion Loss vs. Frequency

Isolation vs. Frequency

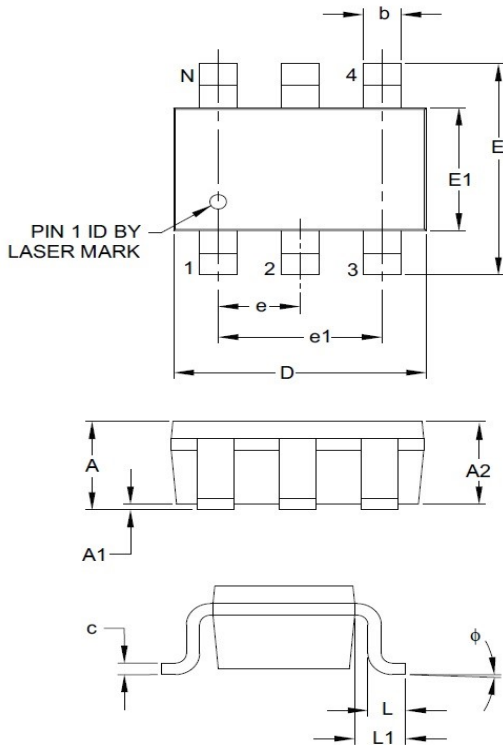
IRL vs. Frequency

ORL vs. Frequency

Package Outline Drawing



Dimension	Limits	MILLIMETERS		
		MIN	NOM	MAX
Number of Pins	N	6		
Pitch	e	0.95 BSC		
Outside Lead Pitch	e1	1.90 BSC		
Overall Height	A	0.90	—	1.45
Molded Package Thickness	A2	0.89	—	1.30
Standoff	A1	0.00	—	0.15
Overall Width	E	2.20	—	3.20
Molded Package Width	E1	1.30	—	1.80
Overall Length	D	2.70	—	3.10
Foot Length	L	0.10	—	0.60
Footprint	L1	0.35	—	0.80
Foot Angle	ϕ	0°	—	30°
Lead Thickness	c	0.08	—	0.26
Lead Width	b	0.20	—	0.51

Suggested PCB Land Pattern and PAD Layout

PCB Land Pattern

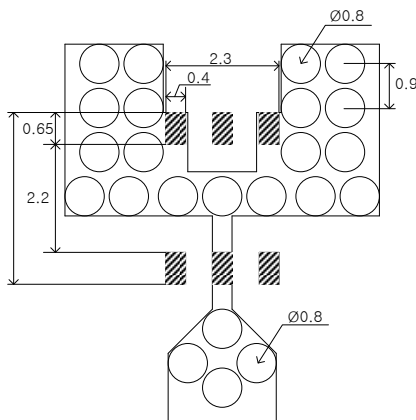

PCB Mounting

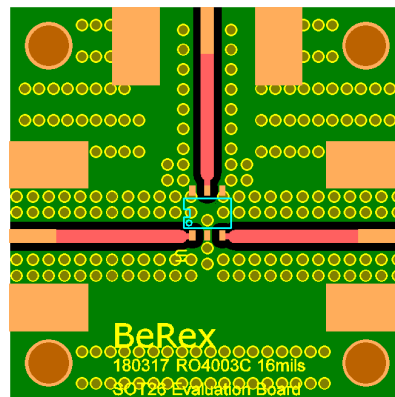

Note : All dimension _ millimeters

PCB lay out _ on BeRex website

Package Marking

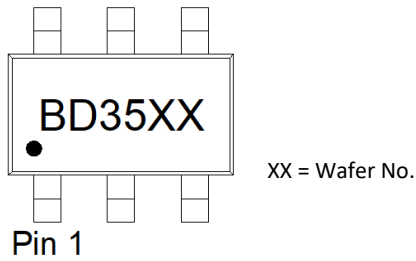

Tape & Reel

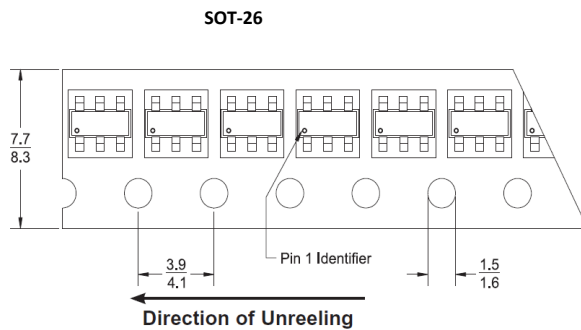

Packaging information:

Tape Width (mm): 8

Reel Size (inches): 7

Device Cavity Pitch (mm): 4

Devices Per Reel: 3000

Lead plating finish

100% Tin Matte finish

(All BeRex products undergoes a 1 hour, 150 degree C, Anneal bake to eliminate thin whisker growth concerns.)

MSL / ESD Rating**MSL Rating:** Level 3 at +265°C convection reflow**Standard:** JEDEC Standard J-STD-020

Proper ESD procedures should be followed when handling this device.

NATO CAGE code:

2	N	9	6	F
---	---	---	---	---