

42.5Ω

Attachment: Unified HEX socket head cap thread 0-80UNF 1/4inch

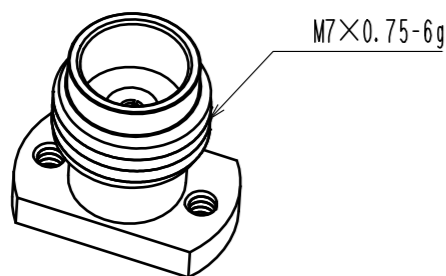

A (10:1)

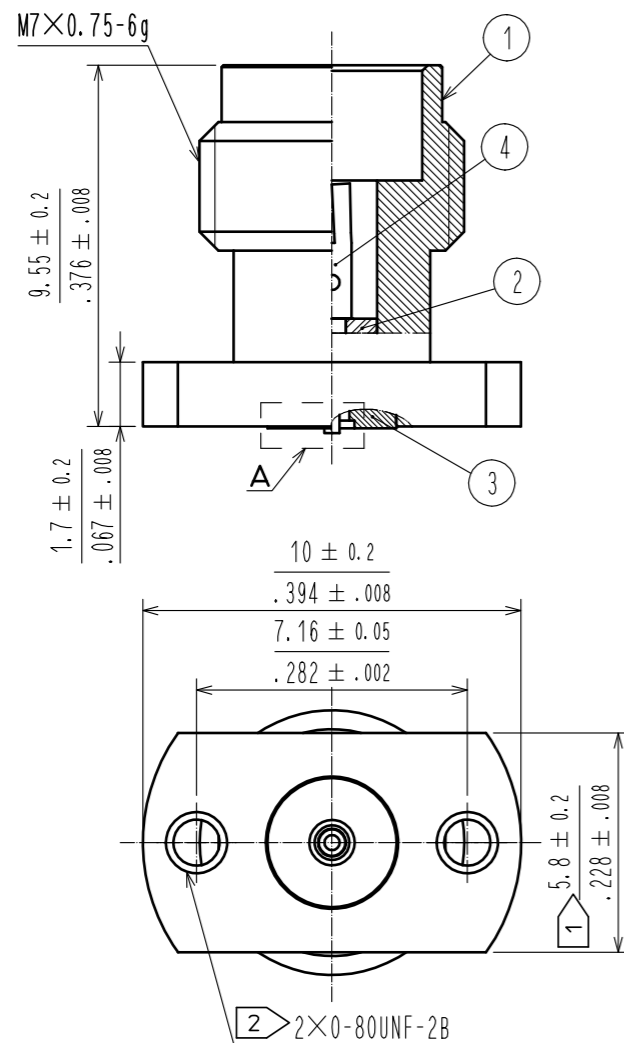
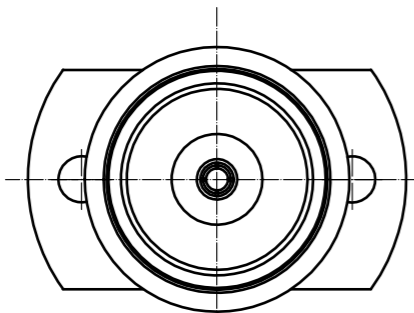
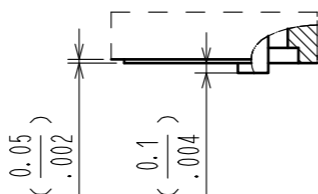

- 1 WHEN MATING THE CONNECTOR, PLEASE HOLD THE FRAISE WITH SPANNER NOT TO PLACE STRESS ON PCB BY THE TORQUE.
- 2 0-80UNF-2B SCREW TIGHTENING TORQUE IS 0.09N·m. PLEASE TIGHTEN THE SCREWS EVENLY WHEN MOUNTING THE CONNECTORS TO ENSURE STABLE ELECTRICAL CONTACT.
- 3 PLEASE USE ATTACHED SCREW AND WASHER FOR PCB MOUNTING. ATTACHED SCREW AND WASHER APPLY PCB THICKNESS t1=2.4 TO 4.25mm.
- 4 INDICATES THE AREA THAT SOLDER MASK IS PROHIBITED.
5. THIS CONNECTOR SHOULD BE USE FOR TEST PORT ONLY.
6. THIS CONNECTOR IS OPTIMIZED FOR IMPEDANCE 42.5Ω SIGNAL LINE.

HRS DRAWING FOR REFERENCE

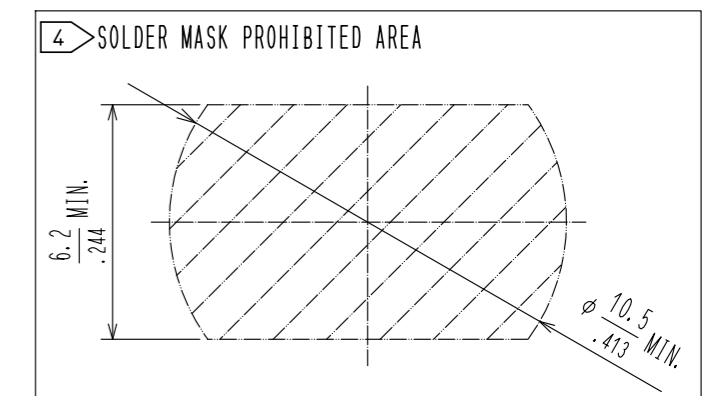
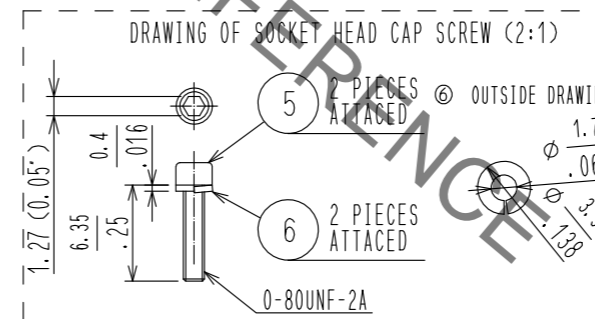
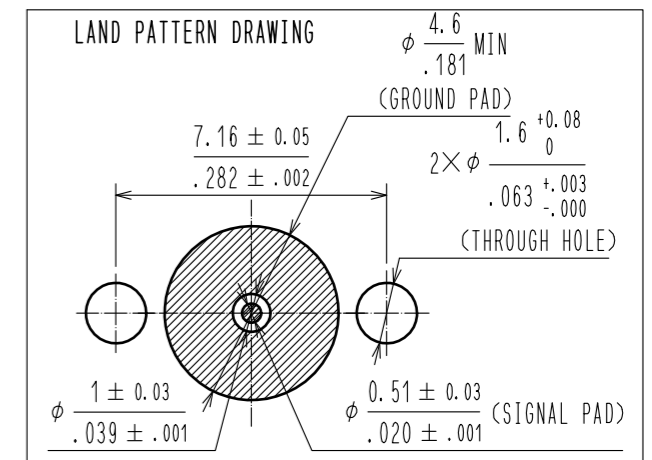
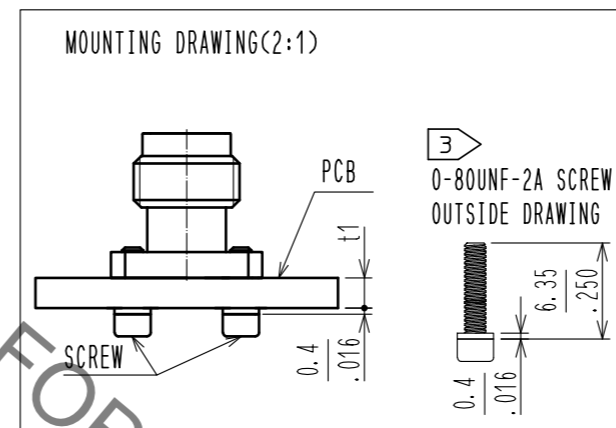

RoHS COMPLIANT

NO.	MATERIAL	FINISH	REMARKS	NO.	MATERIAL	FINISH	REMARKS
3	STAINLESS STEEL	GOLD PLATING		6	STAINLESS STEEL	(SPRING WASHER)	
2	PTFE			5	STEEL	(0-80UNF-2A SCREW)	
1	STAINLESS STEEL	PASSIVATE		4	BERYLLIUM COPPER	GOLD PLATING	

UNITS	SYMBOLS	SCALE	COUNT	DESCRIPTION OF REVISIONS	DESIGNED	CHECKED	DATE
mm		5:1	1	DIS-D-00003223	DS. YAMAKOSHI	NK. NINOMIYA	18.06.19

APPROVED	DATE	DRAWING NO.
KY. SHIMIZU	16.08.30	EDC-368164-16-01
CHECKED	DATE	PART NO.
TO. KATAYAMA	16.08.30	H2.4-R-SR2-IN(16)
DESIGNED	DATE	CODE NO.
TP. MATSUMOTO	16.08.29	CL338-0602-0-16
DRAWN	DATE	
TP. MATSUMOTO	16.08.29	

Aug.1.2022 Copyright 2022 HIROSE ELECTRIC CO., LTD. All Rights Reserved. In case of consideration for using Automotive equipment / device which demand high reliability, kindly contact our sales window correspondents.