

FM340-AHST THRU FM3200-AHST

List

List..... 1

Package outline..... 2

Features..... 2

Mechanical data..... 2

Maximum ratings and Electrical characteristics2

Rating and characteristic curves..... 3

Pinning information.....4

Marking..... 4

Suggested solder pad layout..... 4

Packing information..... 5

Reel packing..... 6

Suggested thermal profiles for soldering processes..... 6

High reliability test capabilities.....7

FM340-AHST THRU FM3200-AHST

3.0A Surface Mount Schottky Barrier Rectifiers 40V-200V

Features

- Well package design with solder pad on the bottom for best thermal performance
- Low profile surface mounted application in order to optimize board space
- Low power loss, high efficiency
- High current capability, low forward voltage drop
- High surge capability
- Guardring for overvoltage protection
- Ultra high-speed switching
- Silicon epitaxial planar chip, metal silicon junction
- Lead-free parts meet RoHS requirements
- Suffix "-H" indicates Halogen free parts, ex. FM340-AHST-H

Mechanical data

- Epoxy:UL94-V0 rated flame retardant
- Case : Molded plastic,DO-221BC / SMA-HST
- Terminals : Solder plated, solderable per MIL-STD-750, Method 2026
- Polarity : Indicated by cathode band
- Mounting Position : Any
- Weight : Approximated 0.037 gram

Package outline

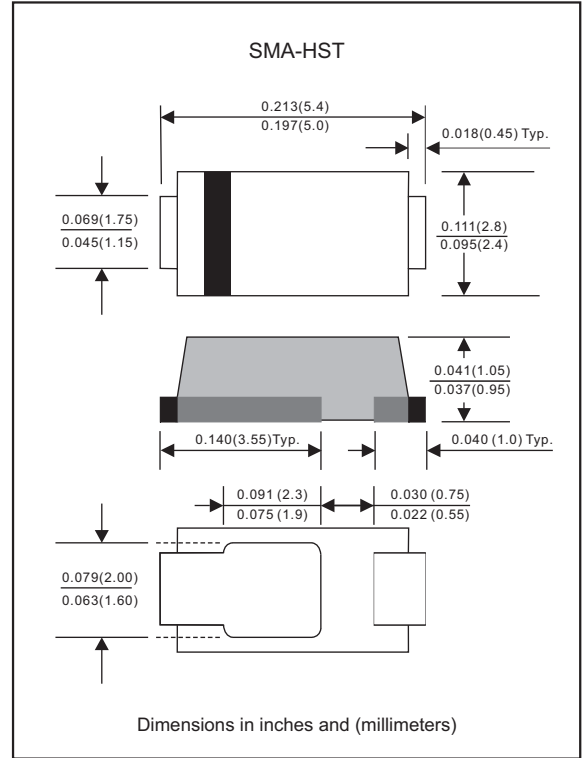

Maximum ratings (AT $T_A=25^\circ\text{C}$ unless otherwise noted)

PARAMETER	SYMBOLS	FM340-AHST	FM345-AHST	FM360-AHST	FM3100-AHST	FM3150-AHST	FM3200-AHST	UNITS
Maximum repetitive peak reverse voltage	V _{RRM}	40	45	60	100	150	200	V
Maximum RMS voltage	V _{RMS}	28	31.5	42	70	105	140	V
Maximum continuous reverse voltage	V _R	40	45	60	100	150	200	V
Maximum average forward rectified current	I _O	3.0						A
Non-repetitive peak forward surge current 8.3ms single half sine-wave	I _{FSM}	80						A
Typical diode junction capacitance (Note 1)	C _J	250						pF
Operating junction temperature range	T _J	-55 to +125		-55 to +150				°C
Storage temperature range	T _{STG}	-65 to +175						°C

Electrical characteristics (AT $T_A=25^\circ\text{C}$ unless otherwise noted)

PARAMETER	SYMBOLS	FM340-AHST	FM345-AHST	FM360-AHST	FM3100-AHST	FM3150-AHST	FM3200-AHST	UNITS
Maximum instantaneous forward voltage at I _F =3.0A	V _F	0.50	0.50	0.70	0.85	0.90	0.92	V
Maximum reverse leakage current at rated V _R	I _R	0.5			20			mA mA
		T _J =25°C						
		T _J =100°C						

Thermal characteristics

PARAMETER	SYMBOLS	FM340-AHST	FM345-AHST	FM360-AHST	FM3100-AHST	FM3150-AHST	FM3200-AHST	UNITS
Typical thermal resistance junction to ambient (Note 2)	R _{θJA}	46						°C / W
Typical thermal resistance junction to case (Note 2)	R _{θJC}	23						°C / W

Notes 1: Measured at 1 MHz and applied reverse voltage of 4.0 VDC
 2: Mounted on FR-4 PCB Copper, minimum recommended pad layout

Rating and characteristic curves (FM340-AHST THRU FM3200-AHST)

FIG.1-TYPICAL FORWARD CURRENT DERATING CURVE

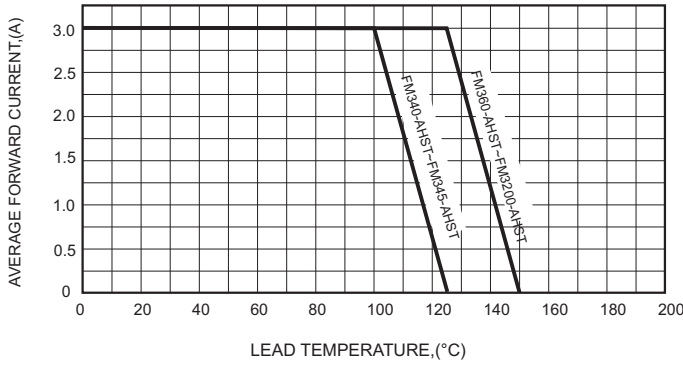

FIG.2-TYPICAL FORWARD CHARACTERISTICS

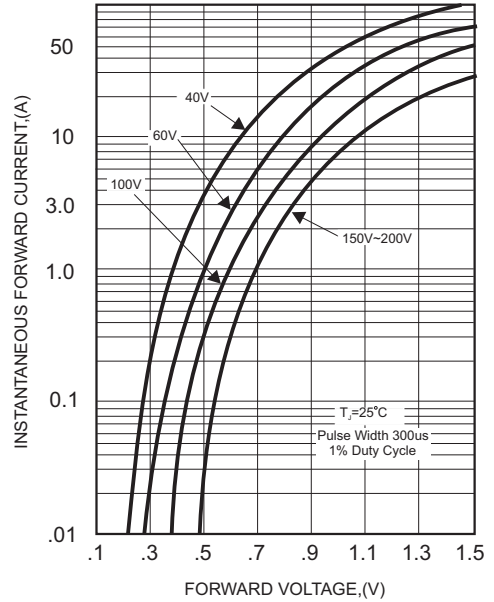

FIG.3-MAXIMUM NON-REPETITIVE FORWARD SURGE CURRENT

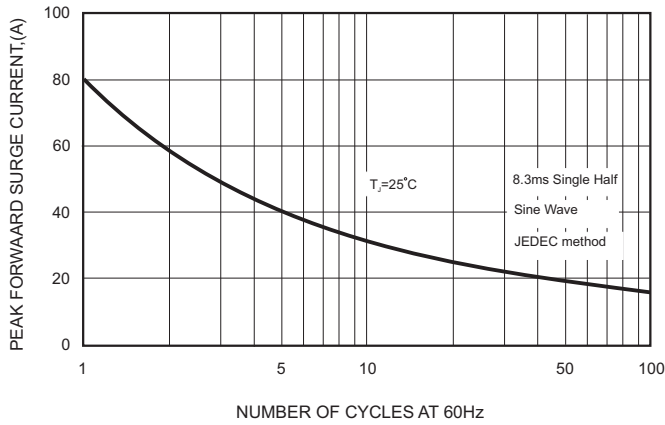

FIG.4-TYPICAL JUNCTION CAPACITANCE

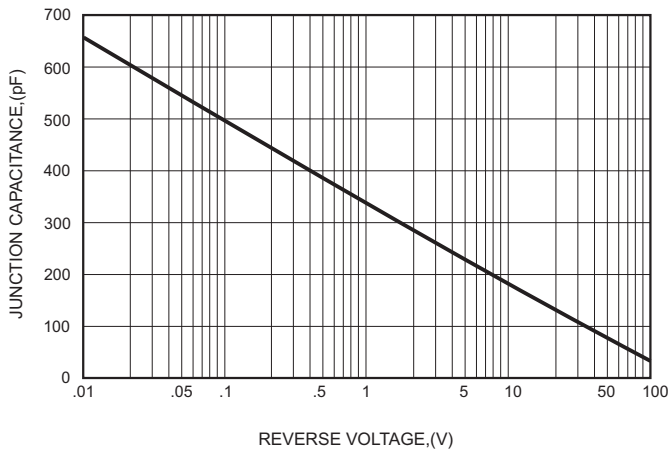
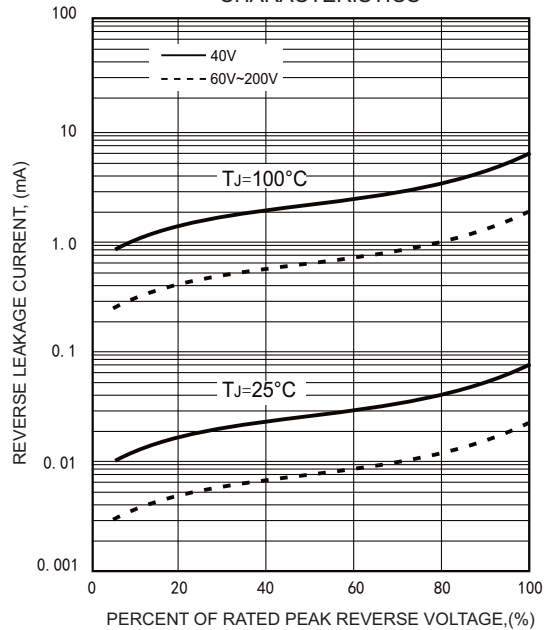



FIG.5 - TYPICAL REVERSE CHARACTERISTICS



FM340-AHST THRU FM3200-AHST

Pinning information

Pin	Simplified outline	Symbol
Pin1 cathode Pin2 anode		

Marking

Type number	Marking code
FM340-AHST	SK34
FM345-AHST	SK34
FM360-AHST	SK36
FM3100-AHST	S310
FM3150-AHST	S315
FM3200-AHST	S320

Suggested solder pad layout

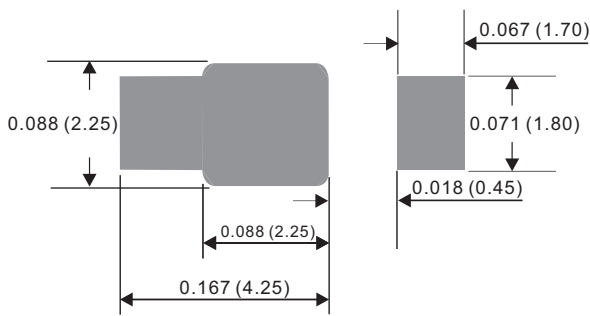

Dimensions in inches and (millimeters)

FM340-AHST THRU FM3200-AHST

Packing information

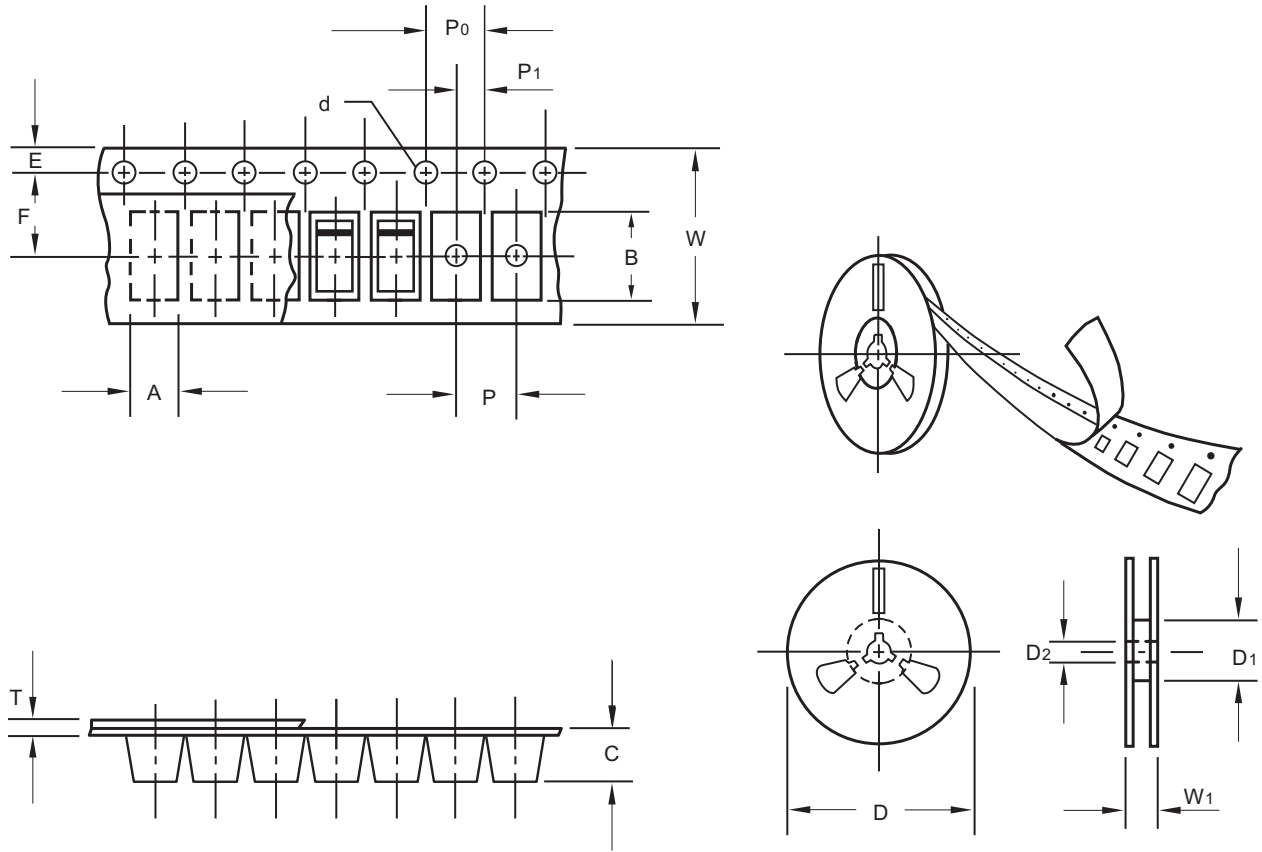

unit:mm

Item	Symbol	Tolerance	SMA-HST
Carrier width	A	0.1	3.00
Carrier length	B	0.1	5.50
Carrier depth	C	0.1	1.20
Sprocket hole	d	0.1	1.50
13" Reel outside diameter	D	2.0	330.00
13" Reel inner diameter	D1	min	50.00
7" Reel outside diameter	D	2.0	178.00
7" Reel inner diameter	D1	min	62.00
Feed hole diameter	D2	0.5	13.00
Sprocket hole position	E	0.1	1.75
Punch hole position	F	0.1	5.50
Punch hole pitch	P	0.1	4.00
Sprocket hole pitch	P0	0.1	4.00
Embossment center	P1	0.1	2.00
Overall tape thickness	T	0.1	0.25
Tape width	W	0.3	12.00
Reel width	W1	1.0	11.40

Note: Devices are packed in accordance with EIA standard RS-481-A and specifications listed above.

FM340-AHST THRU FM3200-AHST

Reel packing

PACKAGE	REEL SIZE	REEL (pcs)	COMPONENT SPACING (m/m)	BOX (pcs)	INNER BOX (m/m)	REEL DIA, (m/m)	CARTON SIZE (m/m)	CARTON (pcs)	APPROX. GROSS WEIGHT (kg)
SMA-HST	7"	3,000	4.0	30,000	183*155*183	178	382*356*392	240,000	18.0
	13"	10,000	4.0	20,000	335*335*38	330	350*330*360	160,000	15.5

Suggested thermal profiles for soldering processes

- 1.Storage environment: Temperature=5°C~40°C Humidity=55%±25%
- 2.Reflow soldering of surface-mount devices

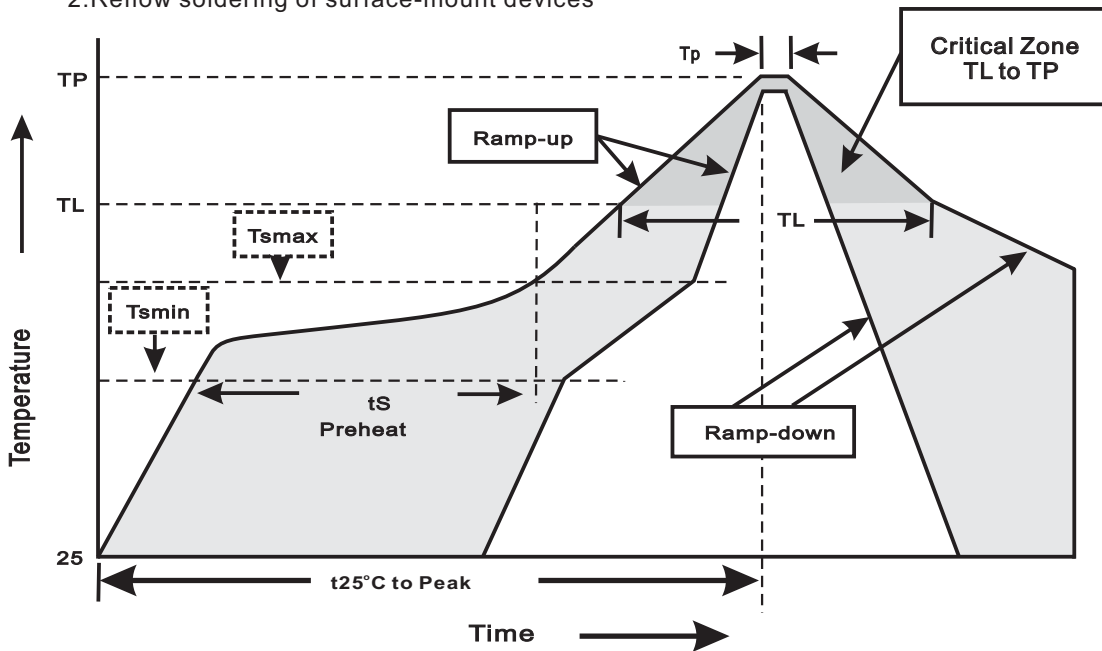

3.Reflow soldering

Profile Feature	Soldering Condition
Average ramp-up rate(T _L to T _P)	<3°C/sec
Preheat -Temperature Min(T _{smín}) -Temperature Max(T _{smáx}) -Time(min to max)(t _s)	150°C 200°C 60~120sec
T _{smáx} to T _L -Ramp-upRate	<3°C/sec
Time maintained above: -Temperature(T _L) -Time(t _L)	217°C 60~260sec
Peak Temperature(T _P)	255°C-0/+5°C
Time within 5°C of actual Peak Temperature(t _P)	10~30sec
Ramp-down Rate	<3°C/sec
Time 25°C to Peak Temperature	<6minutes

FM340-AHST THRU FM3200-AHST**High reliability test capabilities**

Item Test	Conditions	Reference
1. Solder Resistance	at 260±5°C for 10±2sec.	MIL-STD-750D METHOD-2031
2. Solderability	at 245±5°C for 5 sec.	MIL-STD-202F METHOD-208
3. High Temperature Reverse Bias	$V_R=80\%$ rate at $T_J=125^\circ\text{C}$ for 168 hrs.	MIL-STD-750D METHOD-1038
4. Forward Operation Life	Rated average rectifier current at $T_A=25^\circ\text{C}$ for 500hrs.	MIL-STD-750D METHOD-1027
5. Intermittent Operation Life	$T_A = 25^\circ\text{C}$, $I_F = I_O$ On state: power on for 5 min. off state: power off for 5 min. on and off for 500 cycles.	MIL-STD-750D METHOD-1036
6. Pressure Cooker	15P _{SIG} at $T_A=121^\circ\text{C}$ for 4 hrs.	JESD22-A102
7. Temperature Cycling	-55°C to +125°C dwelled for 30 min. and transferred for 5min. total 10 cycles.	MIL-STD-750D METHOD-1051
8. Forward Surge	8.3ms single half sine-wave , one surge.	MIL-STD-750D METHOD-4066-2
9. Humidity	at $T_A=85^\circ\text{C}$, RH=85% for 1000hrs.	MIL-STD-750D METHOD-1021
10. High Temperature Storage Life	at 175°C for 1000 hrs.	MIL-STD-750D METHOD-1031