

## 54ACQ/74ACQ573 • 54ACTQ/74ACTQ573 Quiet Series Octal Latch with TRI-STATE® Outputs

### General Description

The 'ACQ/'ACTQ573 is a high-speed octal latch with buffered common Latch Enable (LE) and buffered common Output Enable ( $\overline{OE}$ ) inputs. The 'ACQ/'ACTQ573 is functionally identical to the 'ACQ/'ACTQ373 but with inputs and outputs on opposite sides of the package. The 'ACQ/'ACTQ utilizes NSC Quiet Series technology to guarantee quiet output switching and improved dynamic threshold performance. FACT Quiet Series™ features GTO™ output control and undershoot corrector in addition to a split ground bus for superior performance.

### Features

- $I_{CC}$  and  $I_{OZ}$  reduced by 50%
- Guaranteed simultaneous switching noise level and dynamic threshold performance
- Guaranteed pin-to-pin skew AC performance
- Improved latch-up immunity
- Inputs and outputs on opposite sides of package allow easy interface with microprocessors
- Outputs source/sink 24 mA
- Faster prop delays than standard 'ACT573
- 4 kV minimum ESD immunity
- Standard Military Drawing (SMD)  
— 'ACTQ573: 5962-8766402

### Logic Symbols

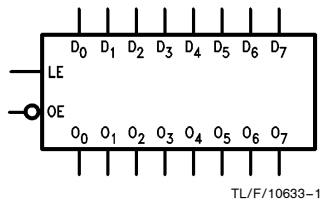

### Connection Diagrams

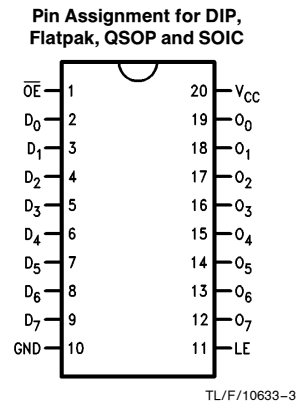
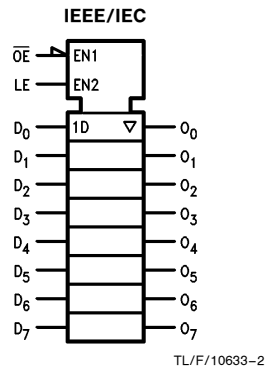

Pin Names	Description
D <sub>0</sub> -D <sub>7</sub>	Data Inputs
LE	Latch Enable Input
$\overline{OE}$	TRI-STATE Output Enable Input
O <sub>0</sub> -O <sub>7</sub>	TRI-STATE Latch Outputs

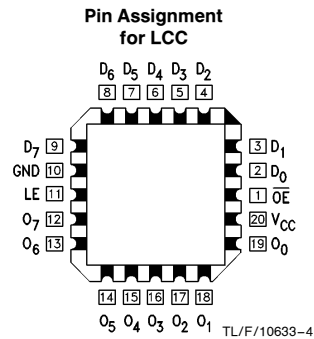

TRI-STATE® is a registered trademark of National Semiconductor Corporation.  
FACT™, FACT Quiet Series™ and GTO™ are trademarks of National Semiconductor Corporation.

## Functional Description

The 'ACQ/'ACTQ573 contains eight D-type latches with TRI-STATE output buffers. When the Latch Enable (LE) input is HIGH, data on the  $D_n$  inputs enters the latches. In this condition the latches are transparent, i.e., a latch output will change state each time its D input changes. When LE is LOW the latches store the information that was present on the D inputs a setup time preceding the HIGH-to-LOW transition of LE. The TRI-STATE buffers are controlled by the Output Enable ( $\overline{OE}$ ) input. When  $\overline{OE}$  is LOW, the buffers are enabled. When  $\overline{OE}$  is HIGH the buffers are in the high impedance mode but this does not interfere with entering new data into the latches.

## Truth Table

Inputs			Outputs
$\overline{OE}$	LE	D	$O_n$
L	H	H	H
L	H	L	L
L	L	X	$O_0$
H	X	X	Z

H = HIGH Voltage  
 L = LOW Voltage  
 Z = High Impedance  
 X = Immaterial  
 $O_0$  = Previous  $O_0$  before HIGH-to-LOW transition of Latch Enable

## Logic Diagram

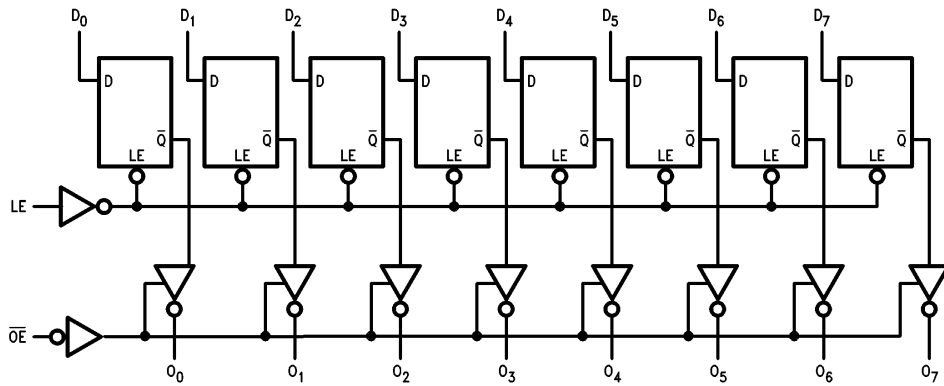

TL/F/10633-5

Please note that this diagram is provided only for the understanding of logic operations and should not be used to estimate propagation delays.

## Absolute Maximum Rating (Note 1)

If Military/Aerospace specified devices are required, please contact the National Semiconductor Sales Office/Distributors for availability and specifications.

Supply Voltage ( $V_{CC}$ )	-0.5V to +7.0V
DC Input Diode Current ( $I_{IK}$ )	
$V_I = -0.5V$	-20 mA
$V_I = V_{CC} + 0.5V$	+20 mA
DC Input Voltage ( $V_I$ )	-0.5V to $V_{CC} + 0.5V$
DC Output Diode Current ( $I_{OK}$ )	
$V_O = -0.5V$	-20 mA
$V_O = V_{CC} + 0.5V$	+20 mA
DC Output Voltage ( $V_O$ )	-0.5V to $V_{CC} + 0.5V$
DC Output Source or Sink Current ( $I_O$ )	$\pm 50$ mA
DC $V_{CC}$ or Ground Current per Output Pin ( $I_{CC}$ or $I_{GND}$ )	$\pm 50$ mA
Storage Temperature ( $T_{STG}$ )	-65°C to +150°C
DC Latchup Source or Sink Current	$\pm 300$ mA
Junction Temperature ( $T_J$ )	
CDIP	175°C
PDIP	140°C

**Note 1:** Absolute maximum ratings are those values beyond which damage to the device may occur. The databook specifications should be met, without exception, to ensure that the system design is reliable over its power supply, temperature, and output/input loading variables. National does not recommend operation of FACT™ circuits outside databook specifications.

## Recommended Operating Conditions

Supply Voltage ( $V_{CC}$ )		2.0V to 6.0V
'ACQ		4.5V to 5.5V
'ACTQ		
Input Voltage ( $V_I$ )		0V to $V_{CC}$
Output Voltage ( $V_O$ )		0V to $V_{CC}$
Operating Temperature ( $T_A$ )		
74ACQ/ACTQ		-40°C to +85°C
54ACQ/ACTQ		-55°C to +125°C
Minimum Input Edge Rate $\Delta V/\Delta t$		
'ACQ Devices		
$V_{IN}$ from 30% to 70% of $V_{CC}$		
$V_{CC}$ @ 3.0V, 4.5V, 5.5V		125 mV/ns
Minimum Input Edge Rate $\Delta V/\Delta t$		
'ACTQ Devices		
$V_{IN}$ from 0.8V to 2.0V		
$V_{CC}$ @ 4.5V, 5.5V		125 mV/ns

**Note:** All commercial packaging is not recommended for applications requiring greater than 2000 temperature cycles from -40°C to +125°C.

## DC Characteristics for 'ACQ Family Devices

Symbol	Parameter	$V_{CC}$ (V)	74ACQ		54ACQ	74ACQ	Units	Conditions
			$T_A = +25^\circ\text{C}$		$T_A = -55^\circ\text{C to } +125^\circ\text{C}$	$T_A = -40^\circ\text{C to } +85^\circ\text{C}$		
			Typ	Guaranteed Limits				
$V_{IH}$	Minimum High Level Input Voltage	3.0	1.5	2.1	2.1	2.1	V	$V_{OUT} = 0.1V$ or $V_{CC} - 0.1V$
		4.5	2.25	3.15	3.15	3.15		
		5.5	2.75	3.85	3.85	3.85		
$V_{IL}$	Maximum Low Level Input Voltage	3.0	1.5	0.9	0.9	0.9	V	$V_{OUT} = 0.1V$ or $V_{CC} - 0.1V$
		4.5	2.25	1.35	1.35	1.35		
		5.5	2.75	1.65	1.65	1.65		
$V_{OH}$	Minimum High Level Output Voltage	3.0	2.99	2.9	2.9	2.9	V	$I_{OUT} = -50 \mu A$
		4.5	4.49	4.4	4.4	4.4		
		5.5	5.49	5.4	5.4	5.4		
		3.0		2.56	2.4	2.46	V	* $V_{IN} = V_{IL}$ or $V_{IH}$ -12 mA $I_{OH}$ -24 mA -24 mA
		4.5		3.86	3.7	3.76		
		5.5		4.86	4.7	4.76		
$V_{OL}$	Maximum Low Level Output Voltage	3.0	0.002	0.1	0.1	0.1	V	$I_{OUT} = 50 \mu A$
		4.5	0.001	0.1	0.1	0.1		
		5.5	0.001	0.1	0.1	0.1		
		3.0		0.36	0.50	0.44	V	* $V_{IN} = V_{IL}$ or $V_{IH}$ 12 mA $I_{OL}$ 24 mA 24 mA
		4.5		0.36	0.50	0.44		
		5.5		0.36	0.50	0.44		

\*All outputs loaded; thresholds on input associated with output under test.

## DC Characteristics for 'ACQ Family Devices (Continued)

Symbol	Parameter	V <sub>CC</sub> (V)	74ACQ		54ACQ	74ACQ		Units	Conditions
			T <sub>A</sub> = +25°C		T <sub>A</sub> = -55°C to +125°C	T <sub>A</sub> = -40°C to +85°C			
			Typ	Guaranteed Limits					
I <sub>IN</sub>	Maximum Input Leakage Current	5.5		±0.1	±1.0		±1.0	μA	V <sub>I</sub> = V <sub>CC</sub> , GND (Note 1)
I <sub>OLD</sub>	†Minimum Dynamic Output Current	5.5			50		75	mA	V <sub>OLD</sub> = 1.65 V <sub>Max</sub>
I <sub>OHD</sub>		5.5			-50		-75	mA	V <sub>OHD</sub> = 3.85 V <sub>Min</sub>
I <sub>CC</sub>	Maximum Quiescent Supply Current	5.5		4.0	80.0		40.0	μA	V <sub>IN</sub> = V <sub>CC</sub> or GND (Note 1)
I <sub>OZ</sub>	Maximum TRI-STATE Leakage Current	5.5		±0.25	±5.0		±2.5	μA	V <sub>I(OE)</sub> = V <sub>IL</sub> , V <sub>IH</sub> V <sub>I</sub> = V <sub>CC</sub> , GND V <sub>O</sub> = V <sub>CC</sub> , GND
V <sub>OLP</sub>	Quiet Output Maximum Dynamic V <sub>OL</sub>	5.0	1.1	1.5				V	Figures 2-12, 13 (Note 2, 3)
V <sub>OLV</sub>	Quiet Output Minimum Dynamic V <sub>OL</sub>	5.0	-0.6	-1.2				V	Figures 2-12, 13 (Notes 2, 3)
V <sub>IHD</sub>	Minimum High Level Dynamic Input Voltage	5.0	3.1	3.5				V	(Notes 2, 4)
V <sub>ILD</sub>	Maximum Low Level Dynamic Input Voltage	5.0	1.9	1.5				V	(Notes 2, 4)

\*All outputs loaded; thresholds on input associated with output under test.

†Maximum test duration 2.0 ms, one output loaded at a time.

**Note 1:** I<sub>IN</sub> and I<sub>CC</sub> @ 3.0V are guaranteed to be less than or equal to the respective limit @ 5.5V V<sub>CC</sub>. I<sub>CC</sub> for 54ACQ @ 25°C is identical to 74ACQ @ 25°C.

**Note 2:** Plastic DIP package.

**Note 3:** Max number of outputs defined as (n). Data Inputs are driven 0V to 5V. One output @ GND.

**Note 4:** Max number of Data Inputs (n) switching. (n - 1) Inputs switching 0V to 5V ('ACQ). Input-under-test switching: 5V to threshold (V<sub>ILD</sub>), 0V to threshold (V<sub>IHD</sub>), f = 1 MHz.

## DC Characteristics for 'ACTQ Family Devices

Symbol	Parameter	V <sub>CC</sub> (V)	74ACTQ		54ACTQ	74ACTQ		Units	Conditions	
			T <sub>A</sub> = +25°C		T <sub>A</sub> = -55°C to +125°C	T <sub>A</sub> = -40°C to +85°C				
			Typ	Guaranteed Limits						
V <sub>IH</sub>	Minimum High Level Input Voltage	4.5	1.5	2.0	2.0		2.0	V	V <sub>OUT</sub> = 0.1V or V <sub>CC</sub> - 0.1V	
		5.5	1.5	2.0	2.0		2.0			
V <sub>IL</sub>	Maximum Low Level Input Voltage	4.5	1.5	0.8	0.8		0.8	V	V <sub>OUT</sub> = 0.1V or V <sub>CC</sub> - 0.1V	
		5.5	1.5	0.8	0.8		0.8			
V <sub>OH</sub>	Minimum High Level Output Voltage	4.5	4.49	4.4	4.4		4.4	V	I <sub>OUT</sub> = -50 μA	
		5.5	5.49	5.4	5.4		5.4			
			4.5		3.86	3.70		3.76	V	*V <sub>IN</sub> = V <sub>IL</sub> or V <sub>IH</sub> -24 mA I <sub>OH</sub> -24 mA
			5.5		4.86	4.70		4.76		
V <sub>OL</sub>	Maximum Low Level Output Voltage	4.5	0.001	0.1	0.1		0.1	V	I <sub>OUT</sub> = 50 μA	
		5.5	0.001	0.1	0.1		0.1			
			4.5		0.36	0.50		0.44	V	*V <sub>IN</sub> = V <sub>IL</sub> or V <sub>IH</sub> 24 mA I <sub>OL</sub> 24 mA
			5.5		0.36	0.50		0.44		

\*All outputs loaded; thresholds on input associated with output under test.

## DC Characteristics for 'ACTQ Family Devices (Continued)

Symbol	Parameter	V <sub>CC</sub> (V)	74ACTQ			54ACTQ		74ACTQ		Units	Conditions
			T <sub>A</sub> = +25°C			T <sub>A</sub> = −55°C to +125°C		T <sub>A</sub> = −40°C to +85°C			
			Typ	Guaranteed Limits							
I <sub>IN</sub>	Maximum Input Leakage Current	5.5		±0.1	±1.0	±1.0	μA	V <sub>I</sub> = V <sub>CC</sub> , GND			
I <sub>OZ</sub>	Maximum TRI-STATE Leakage Current	5.5		±0.25	±5.0	±2.5	μA	V <sub>I</sub> = V <sub>IL</sub> , V <sub>IH</sub> V <sub>O</sub> = V <sub>CC</sub> , GND			
I <sub>CCT</sub>	Maximum I <sub>CC</sub> /Input	5.5	0.6		1.6	1.5	mA	V <sub>I</sub> = V <sub>CC</sub> − 2.1V			
I <sub>OLD</sub>	†Minimum Dynamic Output Current	5.5			50	75	mA	V <sub>OLD</sub> = 1.65V Max			
I <sub>OHD</sub>		5.5			−50	−75	mA	V <sub>OHD</sub> = 3.85V Min			
I <sub>CC</sub>	Maximum Quiescent Supply Current	5.5		4.0	80.0	40.0	μA	V <sub>I</sub> = V <sub>CC</sub> or GND (Note 1)			
V <sub>OLP</sub>	Quiet Output Maximum Dynamic V <sub>OL</sub>	5.0	1.1	1.5			V	Figures 2-12, 13 (Notes 2, 3)			
V <sub>OLV</sub>	Quiet Output Minimum Dynamic V <sub>OL</sub>	5.0	−0.6	−1.2			V	Figures 2-12, 13 (Notes 2, 3)			
V <sub>IHD</sub>	Minimum High Level Dynamic Input Voltage	5.0	1.9	2.2			V	(Notes 2, 4)			
V <sub>ILD</sub>	Maximum Low Level Dynamic Input Voltage	5.0	1.2	0.8			V	(Notes 2, 4)			

†Maximum test duration 2.0 ms, one output loaded at a time.

**Note 1:** I<sub>CC</sub> for 54ACTQ @ 25°C is identical to 74ACTQ @ 25°C.

**Note 2:** Plastic DIP package.

**Note 3:** Max number of outputs defined as (n). Data Inputs are driven 0V to 3V. One output @ GND.

**Note 4:** Max number of data inputs (n) switching. (n − 1) inputs switching 0V to 3V (ACTQ). Input-under-test switching: 3V to threshold (V<sub>ILD</sub>), 0V to threshold (V<sub>IHD</sub>), f = 1 MHz.

## AC Electrical Characteristics

Symbol	Parameter	V <sub>CC</sub> * (V)	74ACQ			54ACQ		74ACQ		Units
			T <sub>A</sub> = +25°C C <sub>L</sub> = 50 pF			T <sub>A</sub> = −55°C to +125°C C <sub>L</sub> = 50 pF		T <sub>A</sub> = −40°C to +85°C C <sub>L</sub> = 50 pF		
			Min	Typ	Max	Min	Max	Min	Max	
t <sub>PHL</sub> , t <sub>PLH</sub>	Propagation Delay D <sub>n</sub> to O <sub>n</sub>	3.3 5.0	2.5 1.5	8.5 5.5	10.5 7.0	1.5 1.5	16.0 11.0	2.5 1.5	11.0 7.5	ns
t <sub>PLH</sub> , t <sub>PHL</sub>	Propagation Delay LE to O <sub>n</sub>	3.3 5.0	2.5 2.0	8.5 6.0	12.0 8.0	1.5 1.5	15.0 11.0	2.5 2.0	12.5 8.5	ns
t <sub>PZL</sub> , t <sub>PZH</sub>	Output Enable Time	3.3 5.0	2.5 1.5	8.5 6.0	13.0 8.5	1.5 1.5	13.5 10.0	2.5 1.5	13.5 9.0	ns
t <sub>PHZ</sub> , t <sub>PLZ</sub>	Output Disable Time	3.3 5.0	1.0 1.0	9.0 6.0	14.5 9.5	1.5 1.0	13.0 10.5	1.0 1.0	15.0 10.0	ns
t <sub>OSHL</sub> , t <sub>OSLH</sub>	Output to Output Skew** D <sub>n</sub> to O <sub>n</sub>	3.3 5.0		1.0 0.5	1.5 1.0				1.5 1.0	ns

\*Voltage Range 5.0 is 5.0V ±0.5V  
Voltage Range 3.3 is 3.3V ±0.3V

\*\*Skew is defined as the absolute value of the difference between the actual propagation delay for any two separate outputs of the same device. The specification applies to any outputs switching in the same direction, either HIGH to LOW (t<sub>OSHL</sub>) or LOW to HIGH (t<sub>OSLH</sub>). Parameter guaranteed by design.

## AC Operating Requirements

Symbol	Parameter	V <sub>CC</sub> * (V)	74ACQ		54ACQ	74ACQ	Units
			T <sub>A</sub> = +25°C C <sub>L</sub> = 50 pF		T <sub>A</sub> = -55°C to +125°C C <sub>L</sub> = 50 pF	T <sub>A</sub> = -40°C to +85°C C <sub>L</sub> = 50 pF	
			Typ	Guaranteed Minimum			
t <sub>S</sub>	Setup Time, HIGH or LOW D <sub>n</sub> to LE	3.3 5.0	0	3.0	4.0	3.0	ns
			0	3.0	4.0	3.0	
t <sub>H</sub>	Hold Time, HIGH or LOW D <sub>n</sub> to LE	3.3 5.0	0	1.5	2.0	1.5	ns
			0	1.5	2.0	1.5	
t <sub>W</sub>	LE Pulse Width, HIGH	3.3 5.0	2.0	4.0	5.0	4.0	ns
			2.0	4.0	5.0	4.0	

\*Voltage Range 5.0 is 5.0V ± 0.5V  
Voltage Range 3.3 is 3.3V ± 0.3V

## AC Electrical Characteristics

Symbol	Parameter	V <sub>CC</sub> * (V)	74ACTQ			54ACTQ		74ACTQ		Units
			T <sub>A</sub> = +25°C C <sub>L</sub> = 50 pF			T <sub>A</sub> = -55°C to +125°C C <sub>L</sub> = 50 pF		T <sub>A</sub> = -40°C to +85°C C <sub>L</sub> = 50 pF		
			Min	Typ	Max	Min	Max	Min	Max	
t <sub>PHL</sub> , t <sub>PLH</sub>	Propagation Delay D <sub>n</sub> to O <sub>n</sub>	5.0	2.0	6.5	7.5	1.5	10.0	2.0	8.0	ns
t <sub>PLH</sub> , t <sub>PHL</sub>	Propagation Delay LE to O <sub>n</sub>	5.0	2.5	7.0	8.5	1.5	11.0	2.5	9.0	ns
t <sub>PZL</sub> , t <sub>PZH</sub>	Output Enable Time	5.0	2.0	7.0	9.0	1.5	11.0	2.0	9.5	ns
t <sub>PHZ</sub> , t <sub>PLZ</sub>	Output Disable Time	5.0	1.0	8.0	10.0	1.5	11.0	1.0	10.5	ns
t <sub>OSSL</sub> , t <sub>OSLH</sub>	Output to Output Skew** D <sub>n</sub> to O <sub>n</sub>	5.0		0.5	1.0				1.0	ns

\*Voltage Range 5.0 is 5.0V ± 0.5V

\*\*Skew is defined as the absolute value of the difference between the actual propagation delay for any two separate outputs of the same device. The specification applies to any outputs switching in the same direction, either HIGH to LOW (t<sub>OSSL</sub>) or LOW to HIGH (t<sub>OSLH</sub>). Parameter guaranteed by design.

## AC Operating Requirements

Symbol	Parameter	V <sub>CC</sub> * (V)	74ACTQ		54ACTQ	74ACTQ	Units
			T <sub>A</sub> = +25°C C <sub>L</sub> = 50 pF		T <sub>A</sub> = -55°C to +125°C C <sub>L</sub> = 50 pF	T <sub>A</sub> = -40°C to +85°C C <sub>L</sub> = 50 pF	
			Typ	Guaranteed Minimum			
t <sub>S</sub>	Setup Time, HIGH or LOW D <sub>n</sub> to LE	5.0	0	3.0	3.5	3.0	ns
t <sub>H</sub>	Hold Time, HIGH or LOW D <sub>n</sub> to LE	5.0	0	1.5	1.5	1.5	ns
t <sub>W</sub>	LE Pulse Width, HIGH	5.0	2.0	4.0	5.0	4.0	ns

\*Voltage Range 5.0 is 5.0V ± 0.5V

## Capacitance

Symbol	Parameter	Typ	Units	Conditions
C <sub>IN</sub>	Input Capacitance	4.5	pF	V <sub>CC</sub> = OPEN
C <sub>PD</sub>	Power Dissipation Capacitance	42.0	pF	V <sub>CC</sub> = 5.0V

## FACT Noise Characteristics

The setup of a noise characteristics measurement is critical to the accuracy and repeatability of the tests. The following is a brief description of the setup used to measure the noise characteristics of FACT.

### Equipment:

Hewlett Packard Model 8180A Word Generator  
PC-163A Test Fixture  
Tektronics Model 7854 Oscilloscope

### Procedure:

1. Verify Test Fixture Loading: Standard Load 50 pF, 500Ω.
2. Deskew the word generator so that no two channels have greater than 150 ps skew between them. This requires that the oscilloscope be deskewed first. Swap out the channels that have more than 150 ps of skew until all channels being used are within 150 ps. It is important to deskew the word generator channels before testing. This will ensure that the outputs switch simultaneously.
3. Terminate all inputs and outputs to ensure proper loading of the outputs and that the input levels are the correct voltage.
4. Set  $V_{CC}$  to 5.0V.
5. Set the word generator to toggle all but one output at a frequency of 1 MHz. Greater frequencies will increase DUT heating and affect the results of the measurement.

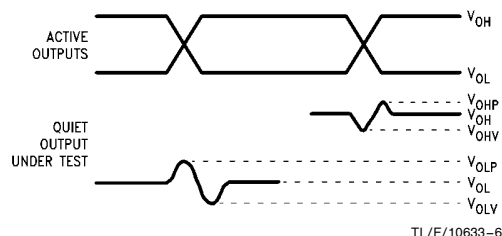

**FIGURE 1. Quiet Output Noise Voltage Waveforms**

**Note A:**  $V_{OHV}$  and  $V_{OLP}$  are measured with respect to ground reference.

**Note B:** Input pulses have the following characteristics:  $f = 1$  MHz,  $t_r = 3$  ns,  $t_f = 3$  ns, skew < 150 ps.

6. Set the word generator input levels at 0V LOW and 3V HIGH for ACT devices and 0V LOW and 5V HIGH for AC devices. Verify levels with a digital volt meter.

### $V_{OLP}/V_{OLV}$ and $V_{OHP}/V_{OHV}$ :

- Determine the quiet output pin that demonstrates the greatest noise levels. The worst case pin will usually be the furthest from the ground pin. Monitor the output voltages using a 50Ω coaxial cable plugged into a standard SMB type connector on the test fixture. Do not use an active FET probe.
- Measure  $V_{OLP}$  and  $V_{OLV}$  on the quiet output during the HL transition. Measure  $V_{OHP}$  and  $V_{OHV}$  on the quiet output during the LH transition.
- Verify that the GND reference recorded on the oscilloscope has not drifted to ensure the accuracy and repeatability of the measurements.

### $V_{ILD}$ and $V_{IHD}$ :

- Monitor one of the switching outputs using a 50Ω coaxial cable plugged into a standard SMB type connector on the test fixture. Do not use an active FET probe.
- First increase the input LOW voltage level,  $V_{IL}$ , until the output begins to oscillate. Oscillation is defined as noise on the output LOW level that exceeds  $V_{IL}$  limits, or on output HIGH levels that exceed  $V_{IH}$  limits. The input LOW voltage level at which oscillation occurs is defined as  $V_{ILD}$ .
- Next increase the input HIGH voltage level on the word generator,  $V_{IH}$  until the output begins to oscillate. Oscillation is defined as noise on the output LOW level that exceeds  $V_{IL}$  limits, or on output HIGH levels that exceed  $V_{IH}$  limits. The input HIGH voltage level at which oscillation occurs is defined as  $V_{IHD}$ .
- Verify that the GND reference recorded on the oscilloscope has not drifted to ensure the accuracy and repeatability of the measurements.

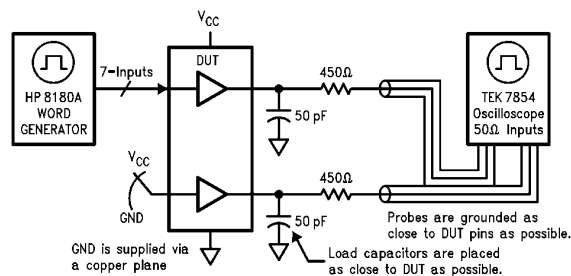

**FIGURE 2. Simultaneous Switching Test Circuit**

## Ordering Information

The device number is used to form part of a simplified purchasing code where the package type and temperature range are defined as follows:

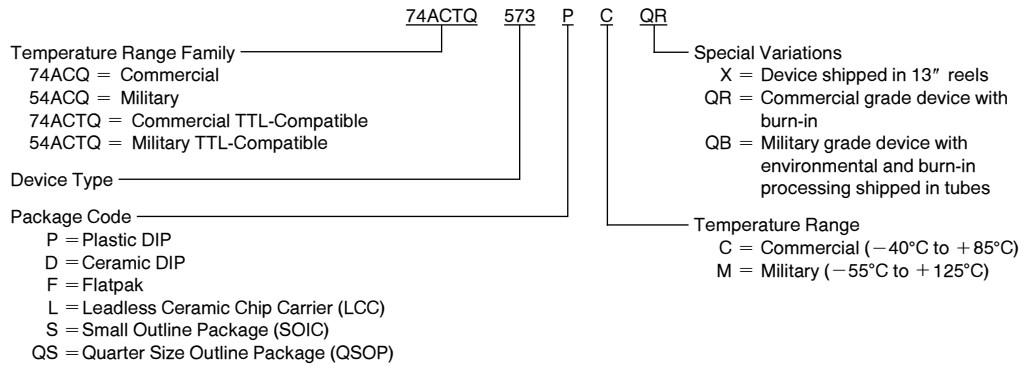



**Physical Dimensions** inches (millimeters)

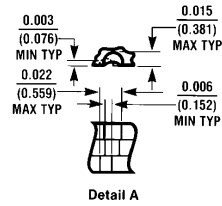
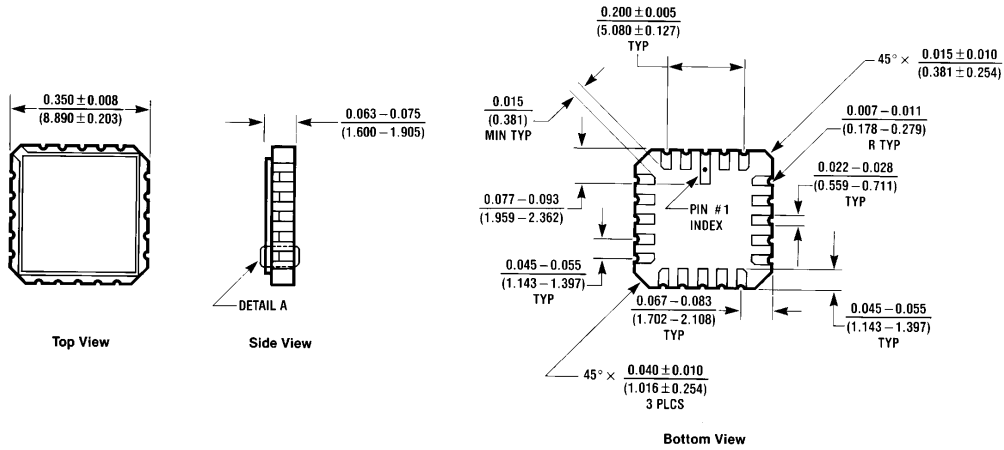

**20-Terminal Ceramic Leadless Chip Carrier (L)  
 NS Package Number E20A**

E20A (REV D)

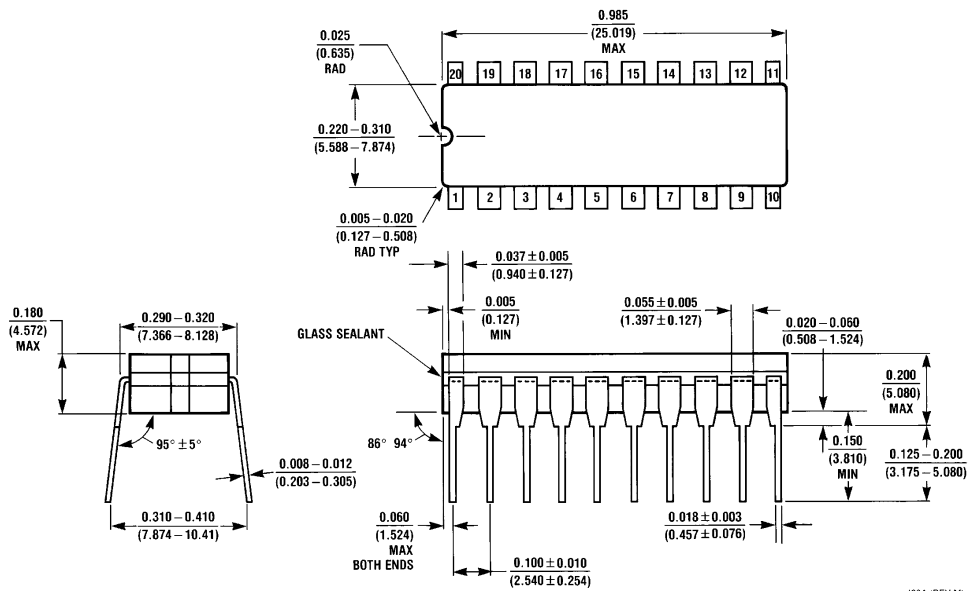

**20-Lead Ceramic Dual-In-Line Package (D)  
 NS Package Number J20A**

J20A (REV M)

**Physical Dimensions** inches (millimeters) (Continued)

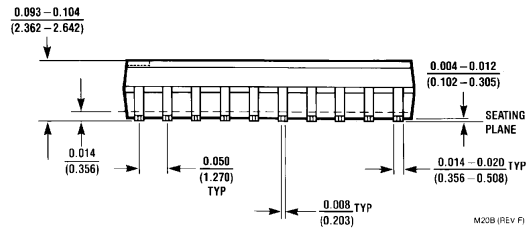
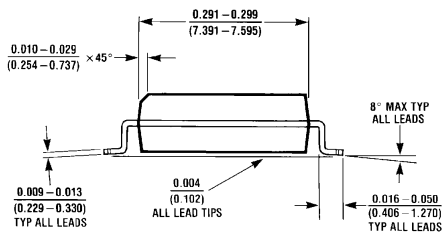
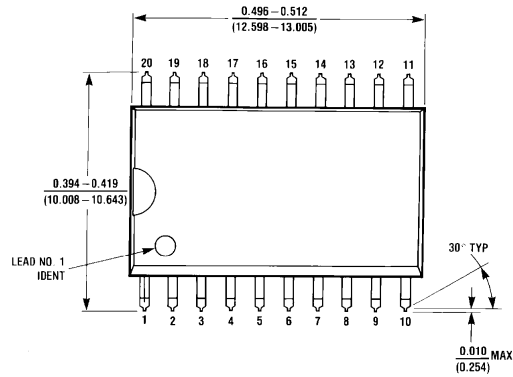

**20-Lead Small Outline Integrated Circuit (S)  
NS Package Number M20B**

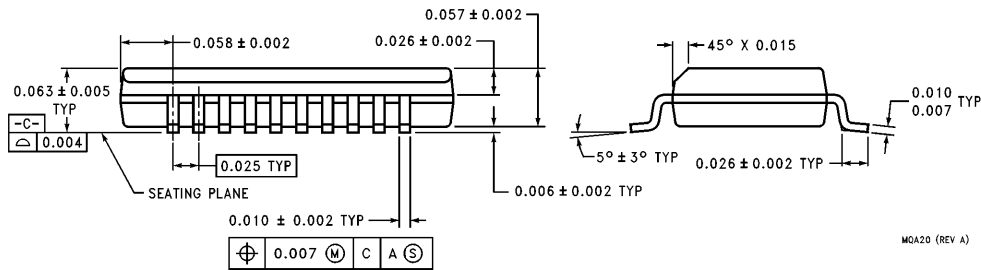
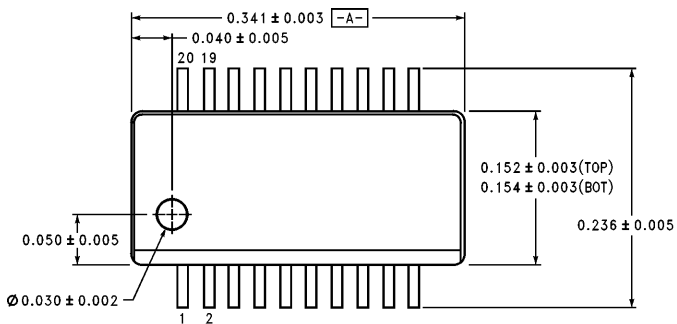

**20-Lead Quarter Size Outline Package (QS)  
NS Package Number MQA20**

**Physical Dimensions** inches (millimeters) (Continued)

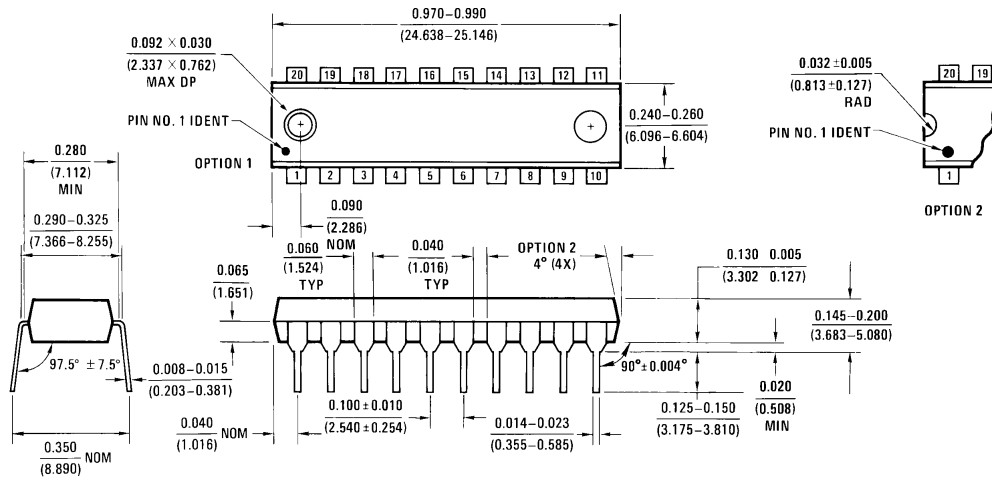

**20-Lead Plastic Dual-In-Line Package (P)**  
**NS Package Number N20B**

N20B (REV A)

**Physical Dimensions** inches (millimeters) (Continued)

Lit. # 114669

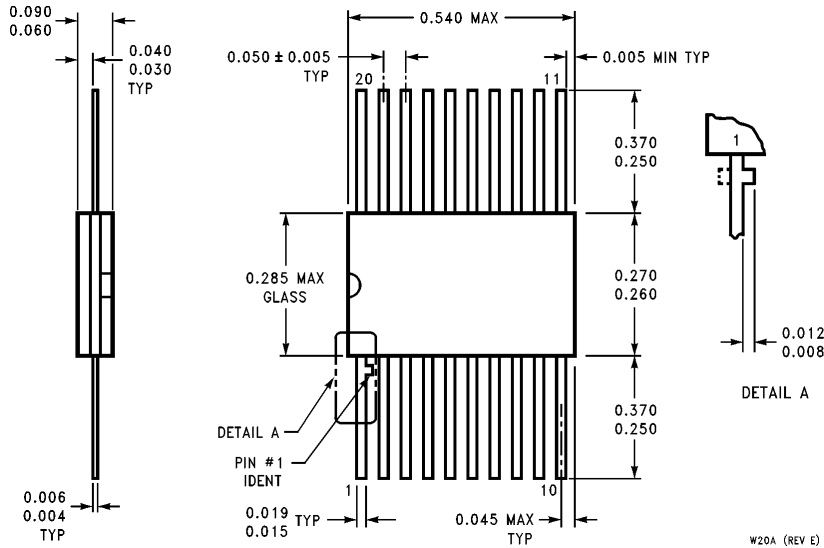

**20-Lead Ceramic Flatpak (F)  
 NS Package Number W20A**

W20A (REV E)

**LIFE SUPPORT POLICY**

NATIONAL'S PRODUCTS ARE NOT AUTHORIZED FOR USE AS CRITICAL COMPONENTS IN LIFE SUPPORT DEVICES OR SYSTEMS WITHOUT THE EXPRESS WRITTEN APPROVAL OF THE PRESIDENT OF NATIONAL SEMICONDUCTOR CORPORATION. As used herein:

1. Life support devices or systems are devices or systems which, (a) are intended for surgical implant into the body, or (b) support or sustain life, and whose failure to perform, when properly used in accordance with instructions for use provided in the labeling, can be reasonably expected to result in a significant injury to the user.
2. A critical component is any component of a life support device or system whose failure to perform can be reasonably expected to cause the failure of the life support device or system, or to affect its safety or effectiveness.



**National Semiconductor Corporation**  
 2900 Semiconductor Drive  
 P.O. Box 58090  
 Santa Clara, CA 95052-8090  
 Tel: (1800) 272-9959  
 TWX: (910) 339-9240

**National Semiconductor GmbH**  
 Livry-Gargan-Str. 10  
 D-82256 Fürstenfeldbruck  
 Germany  
 Tel: (81-41) 35-0  
 Telex: 527849  
 Fax: (81-41) 35-1

**National Semiconductor Japan Ltd.**  
 Sumitomo Chemical  
 Engineering Center  
 Bldg. 7F  
 1-7-1, Nakase, Mihama-Ku  
 Chiba-City,  
 Chiba Prefecture 261  
 Tel: (043) 299-2300  
 Fax: (043) 299-2500

**National Semiconductor Hong Kong Ltd.**  
 13th Floor, Straight Block,  
 Ocean Centre, 5 Canton Rd.  
 Tsimshatsui, Kowloon  
 Hong Kong  
 Tel: (852) 2737-1600  
 Fax: (852) 2736-9960

**National Semicondutores Do Brazil Ltda.**  
 Rue Deputado Lacorda Franco  
 120-3A  
 Sao Paulo-SP  
 Brazil 05418-000  
 Tel: (55-11) 212-5066  
 Telex: 391-1131931 NSBR BR  
 Fax: (55-11) 212-1181

**National Semiconductor (Australia) Pty. Ltd.**  
 Building 16  
 Business Park Drive  
 Monash Business Park  
 Nottingham, Melbourne  
 Victoria 3168 Australia  
 Tel: (3) 558-9999  
 Fax: (3) 558-9998

National does not assume any responsibility for use of any circuitry described, no circuit patent licenses are implied and National reserves the right at any time without notice to change said circuitry and specifications.

This datasheet has been download from:

[www.datasheetcatalog.com](http://www.datasheetcatalog.com)

Datasheets for electronics components.

# National Semiconductor was acquired by Texas Instruments.

[http://www.ti.com/corp/docs/investor\\_relations/pr\\_09\\_23\\_2011\\_national\\_semiconductor.html](http://www.ti.com/corp/docs/investor_relations/pr_09_23_2011_national_semiconductor.html)

This file is the datasheet for the following electronic components:

74ACTQ573 - <http://www.ti.com/product/74actq573?HQS=TI-null-null-dscatalog-df-pf-null-wwe>

74ACQ573 - <http://www.ti.com/product/74acq573?HQS=TI-null-null-dscatalog-df-pf-null-wwe>

54ACTQ573 - <http://www.ti.com/product/54actq573?HQS=TI-null-null-dscatalog-df-pf-null-wwe>

54ACQ573 - <http://www.ti.com/product/54acq573?HQS=TI-null-null-dscatalog-df-pf-null-wwe>