

CCC規格についてはお問い合わせ下さい
CCC Standard for Safety : please contact us
安全規格 : UL file # E64205
Standard for Safety: UL file # E64205

● 淡青緑色 Color: Light Blue

EPH-2V (プリント基板縦取付用) For printed circuit board <vertical>

EPH-2V
Net weight 5.9g

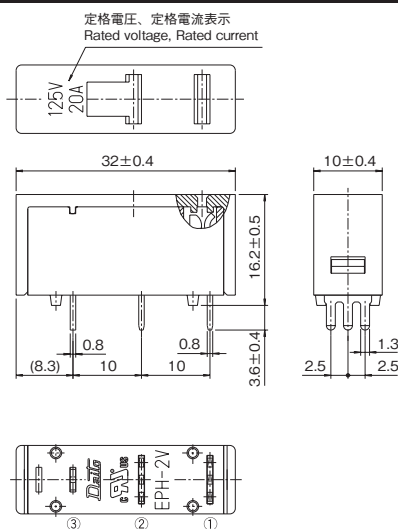

EPH-4V (プリント基板縦取付用) For printed circuit board <vertical>

EPH-4V
Net weight 6.6g

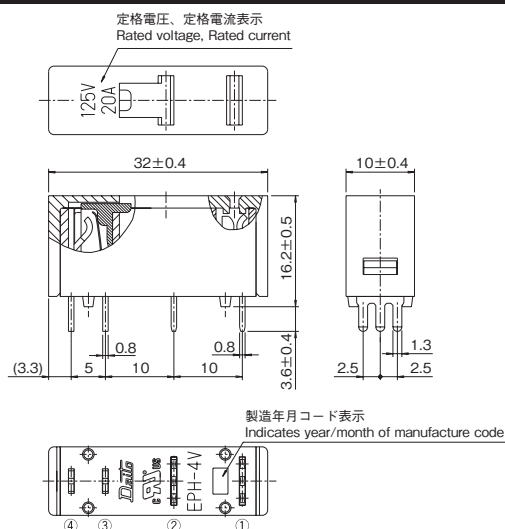

EPH-4P (プリント基板横取付用) For printed circuit board <horizontal>

EPH-4P
Net weight 5.7g

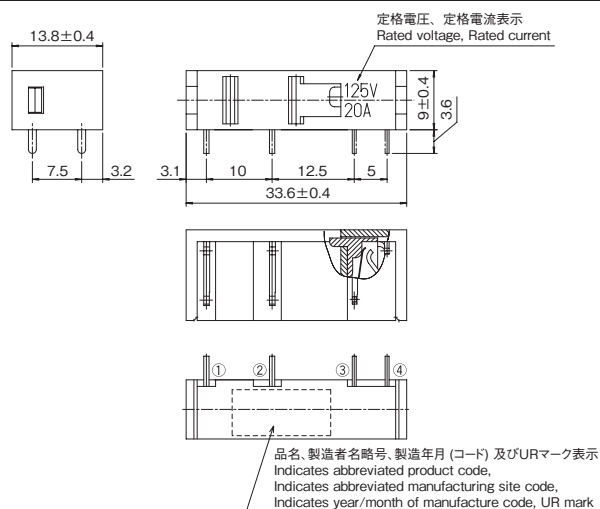
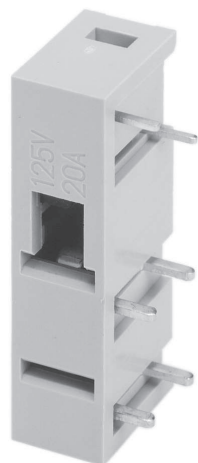

■ カタログの記載内容は予告なく変更することがありますので、ご注文に際してはご確認ください。
■ Information in this catalog is subject to change without notice. Please confirm product information when ordering.



品名 Cat. No.	定格電圧 Rated Voltage	定格電流 Rated Current	耐電圧 Withstand Voltage			絶縁抵抗 Insulation Resistance	接触抵抗 Contact Resistance
			警報端子間 Between alarm terminal	負荷端子と警報負荷端子間 Between load terminal and alarm terminal	その他の組み合わせ Other		
EPH-2V EPH-4V EPH-4P	AC/DC 125V	20A	AC 1,250V 1min	AC 3,750V 1min	AC 2,500V 1min	Min. 100M Ω at 500VDC	Max. 10m Ω per terminal (5VDC 100mA)

警報接点容量 Alarm contact capacity

容量 Capacity	最大使用電圧 Voltage	最大使用電流 Current
25VA	Max. AC/DC 125V	Max. 0.5A

端子名称 Terminal

ホルダ端子番号 Holder terminal No.	EPH-2V (警報回路なし) Without alarm contact	EPH-4V, 4P (警報回路あり) With alarm contact
1	電源・負荷端子どちらでも可 Power supply or load terminal	電源端子 Power supply terminal
2		負荷端子 Load terminal
3	固定用端子 Terminal for fixation	警報負荷端子 Alarm load terminal
4	—	警報電源端子 Alarm power supply terminal

EPH-2V, 4V

プリント基板実装穴寸法図 (公差± 0.1) ボトムビュー
Mounting hole dimensions for PCB (tolerance: ± 0.1)
Bottom view

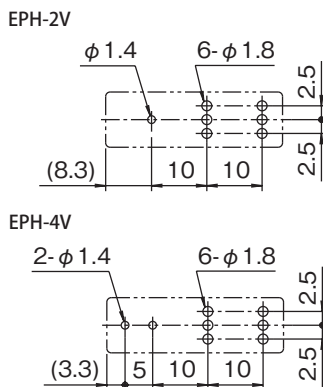

取付状態図における矢印方向から見た穴配置。
The layout of mounting holes seen from the direction of the arrow in the mounting method drawing.

取付状態
Mounting view

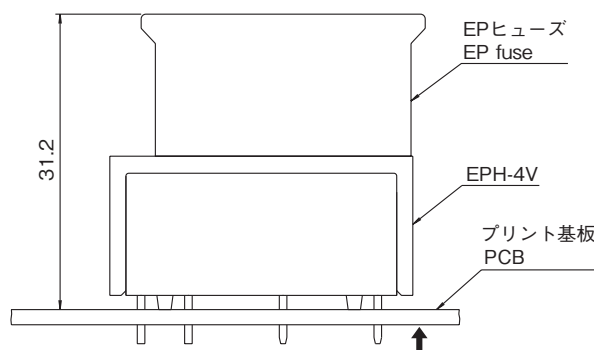

EPH-4P

プリント基板実装穴寸法図 (公差± 0.1) ボトムビュー
Mounting hole dimensions for PCB (tolerance: ± 0.1)
Bottom view

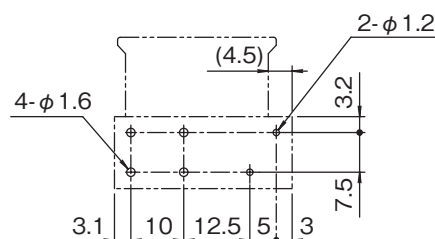

取付状態図における矢印方向から見た穴配置。
The layout of mounting holes seen from the direction of the arrow in the mounting method drawing.

取付状態
Mounting view

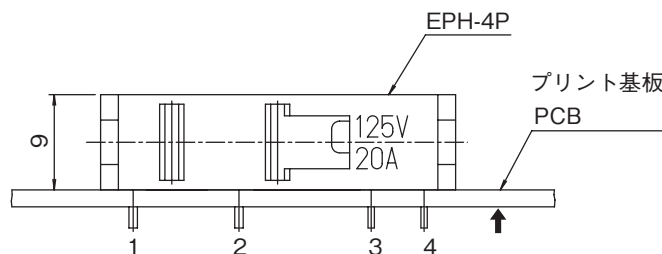

■ カタログの記載内容は予告なく変更することがありますので、ご注文に際してはご確認ください。
■ Information in this catalog is subject to change without notice. Please confirm product information when ordering.