

Aug.1.2022 Copyright 2022 HIROSE ELECTRIC CO., LTD. All Rights Reserved.
In case of consideration for using Automotive equipment / device which demand high reliability, kindly contact our sales window correspondents.

CABLE ASSEMBLY TOOL
FOR SOLDERING : HRM-200/SO-MD
FOR PRESS FITTING : HRM-200-BPJBN/CV-MD

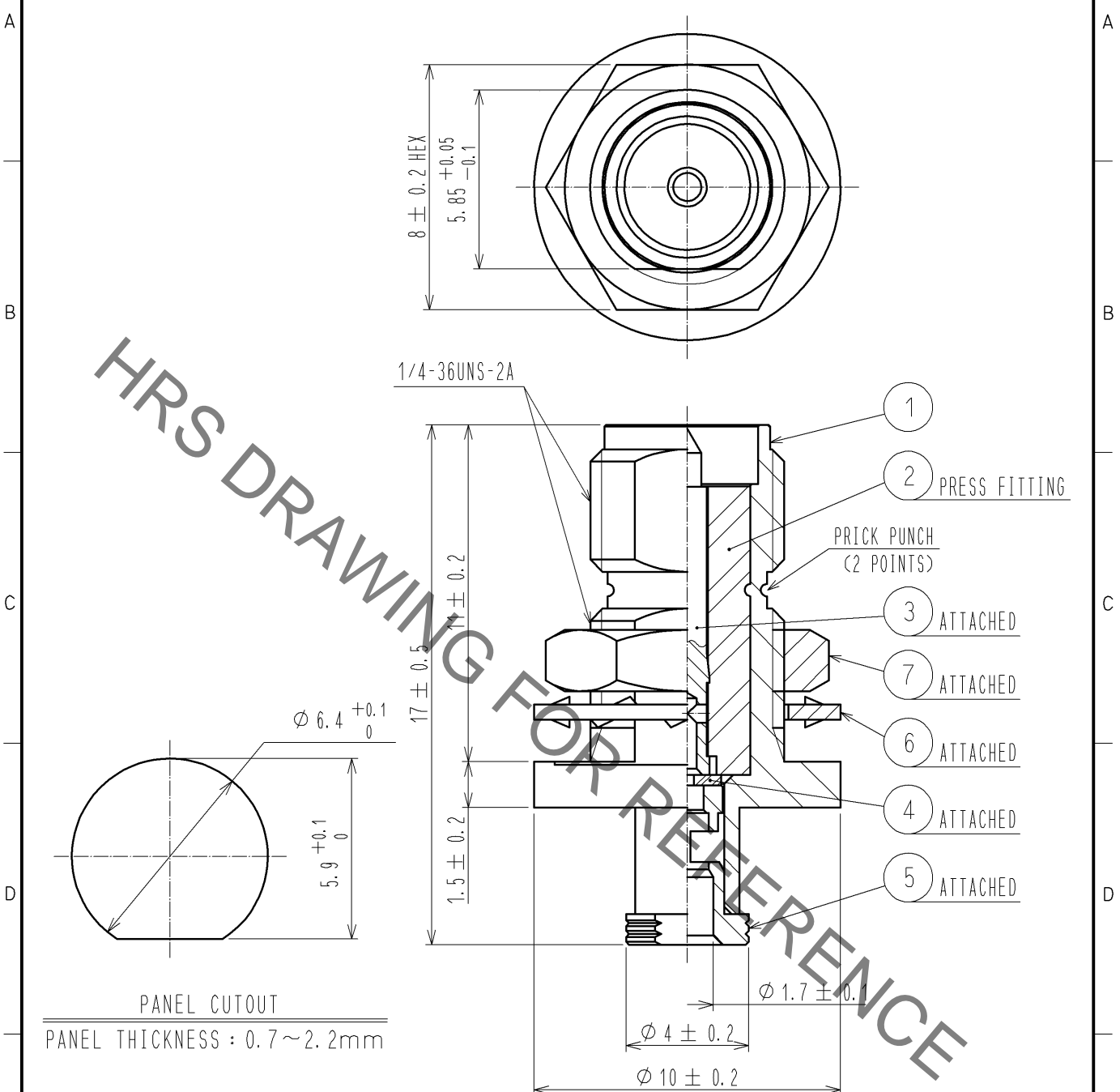

PANEL CUTOUT
PANEL THICKNESS : 0.7~2.2mm

RoHS COMPLIANT

4	PTFE						
3	BRASS	GOLD PLATING	7	BRASS	NICKEL PLATING		
2	PTFE		6	PHOSPHOR BRONZE	NICKEL PLATING		
1	BRASS	NICKEL PLATING	5	BRASS	GOLD PLATING		
NO.	MATERIAL	FINISH .	REMARKS	NO.	MATERIAL	FINISH .	REMARKS

UNITS mm		SCALE 5 : 1	COUNT 	DESCRIPTION OF REVISIONS	DESIGNED	CHECKED	DATE
-------------	--	----------------	-----------	--------------------------	----------	---------	------

HRS HIROSE ELECTRIC CO., LTD.	APPROVED : MH. YAMANE	08.10.23	DRAWING NO.	EDC4-318050-00
	CHECKED : TO. KATAYAMA	08.10.23	PART NO.	SMA(R)-200-088BPJBN
	DESIGNED : TS. KANEKO	08.10.23	CODE NO.	CL323-0901-2-00
	DRAWN : TS. KANEKO	08.10.23		1/1