



Specifications of Analog Silicon Microphone

GTM2718AB381WNB2

Rev 1.0

(RoHS Compliant & Halogen Free)

GMEMS Approvals	Documentor	Verifier	Approver
	王海军	张 杰	王云龙
Customer Approvals	TESTED BY	CHECKED BY	APPROVED BY



1. PRODUCT DESCRIPTION

GTM2718AB381WNB2 is a miniature, high-performance, low power consumption silicon microphone with analog output and bottom-port for sound input. It is a cost-effective alternative to traditional electret condenser microphone (ECM). Provided on tap-and-reel, it is ideally suited for high volume applications. And it can be attached directly to customer’s PCB using standard automatic pick-and-place equipment and surface-mounted via standard solder reflow equipment.

GTM2718AB381WNB2 is designed for Active Noise Cancellation in TWS earphones that require bottom-port sound inlet silicon microphones, although it can be used for other applications.

2. APPLICATIONS:

- 1). Active Noise Cancellation in TWS earphones
- 2). Smart electronic devices
- 3). Headphone and headset accessories

3. FEATURES

- 2.75×1.85×0.95mm Bottom-port Package
- Sensitivity of -38(±1) dBV/Pa
- SNR of 64dB(A)
- Low Power Consumption
- Flat Frequency Response
- High Reliability
- Good RF Immunity
- Lead-free Reflow Process Compatible
- Omni-directional
- Ultra-stable Performance

4. ABSOLUTE MAXIMUM RATINGS

Supply Voltage: VDD to GND-0.3V~5V

ESD Tolerance:

The Lid Mode8kV

The I/O Pin Mode4kV

TEMPERATURE CHARACTERISTICS					
Parameter	Conditions	Min	Typ	Max	Unit
Operating Temperature		-40		+85	°C
Storage Temperature	Solder on PC board	-40		+105	°C
	In Tape and Reel	-10		+50	°C

CAUTION: Stresses above those listed in “Absolute Maximum Ratings” may cause permanent damage to the device. This is a stress only rating and operation of the device at these or any other conditions above those indicated in the operational sections of this specification is not implied.



5. ACOUSTIC & ELECTRICAL SPECIFICATIONS

Test Conditions:

Ta = 25°C, R.H. = 50±20%, V_{DD} = 2.0V, Input sound pressure P_{IN} = 94dB SPL@1kHz

SNR & noise floor measurement is based on 100Hz ~ 10KHz passband with A-Weighting filter applied unless specifically specified in the table below.

Parameter	Conditions	Min	Typ	Max	Unit
Directivity		Omni-Directional			
Power Supply Voltage		1.6	-	3.6	V
Sensitivity	@1KHz (0 dB = 1V/Pa)	-39	-38	-37	dBV/Pa
Signal-to-Noise Ratio (SNR)	@1KHz (0 dB = 1V/Pa) (100Hz ~ 10KHz)	63	64	-	dB(A)
Signal-to-Noise Ratio (SNR)	@1KHz (0 dB = 1V/Pa) (20Hz ~ 20KHz)	62	63	-	dB(A)
Total Harmonic Distortion (THD)	@100dB SPL @1KHz	-	0.2	-	%
Acoustic Overload Point (AOP)	@1KHz, THD < 10%	-	127	-	dB SPL
Power Supply Rejection (PSR)	217Hz, 100mVpp square wave	-	-96	-	dB
Sensitivity Loss Across Power Supply Voltage	Change in sensitivity from 1.6V to 3.6V power supply voltage	No change			dB
Total Operation Current	1.6V~3.6V power supply voltage	-	-	160	uA
Output Impedance	@1KHz (0dB=1V/Pa)	-	200	-	Ω



6. FREQUENCY RESPONSE CURVE

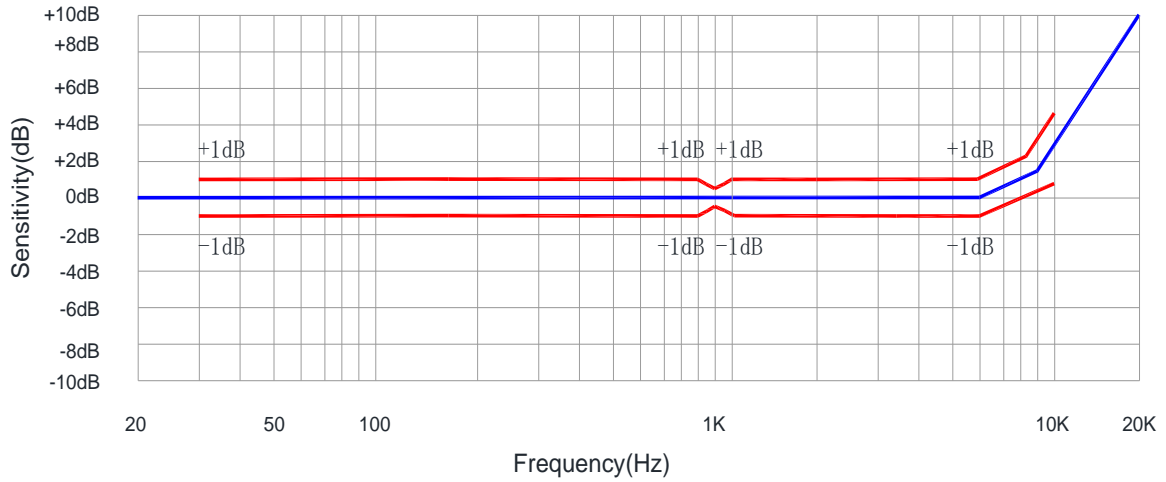
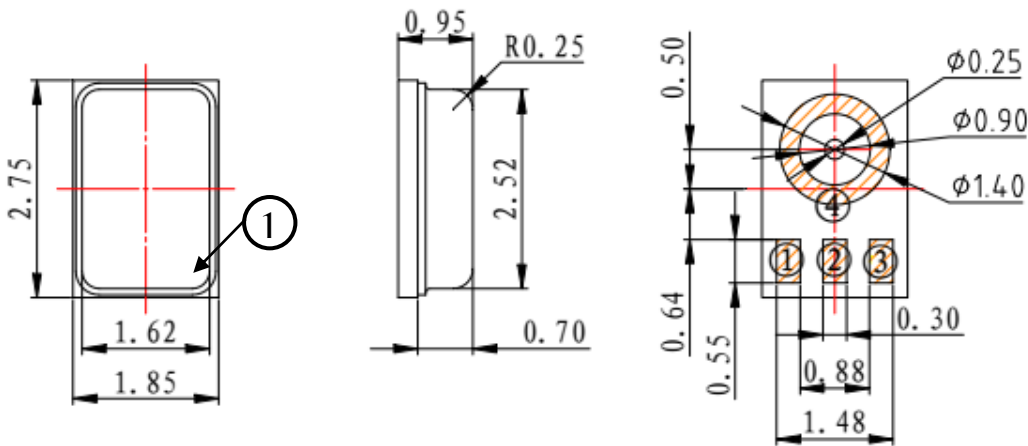

Figure 1. Typical free field frequency response (Normalized to 1 KHz)

7. MECHANICAL SPECIFICATIONS



ITEM	DIMENSION	TOLERANCE	UNITS
LENGTH(L)	2.75	±0.10	mm
WIDTH(W)	1.85	±0.10	mm
HEIGHT(H)	0.95	±0.10	mm
ACOUSTIC PORT(AP)	Φ0.25	±0.10	mm

PIN OUTPUT	
PIN#	FUNCTION
1	OUTPUT
2	GND
3	VDD
4	GND

Note: Dimensions are in millimeters unless otherwise specified. Tolerance ±0.15mm unless otherwise specified

Figure 2. Detailed mechanical drawings

8. RECOMMENDED CUSTOMER LANDING PATTERN

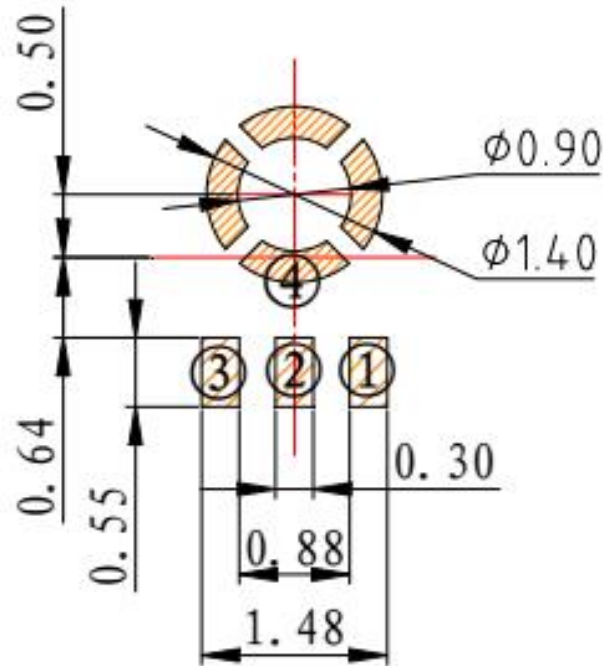

Figure 3. Recommended landing pattern on customers' PCB

9. RECOMMENDED INTERFACE CIRCUIT

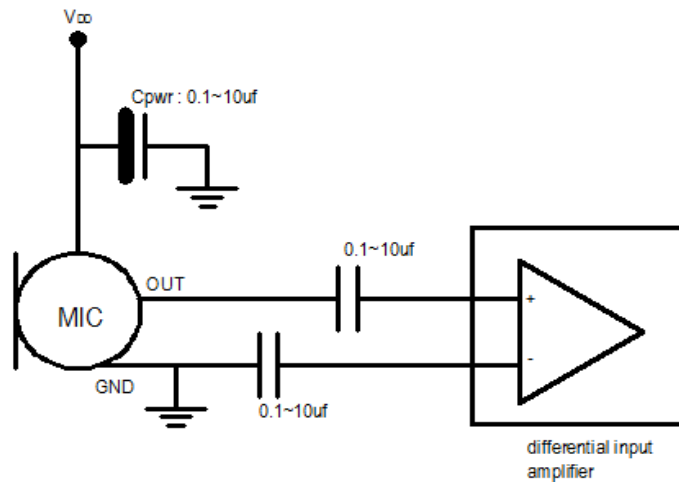
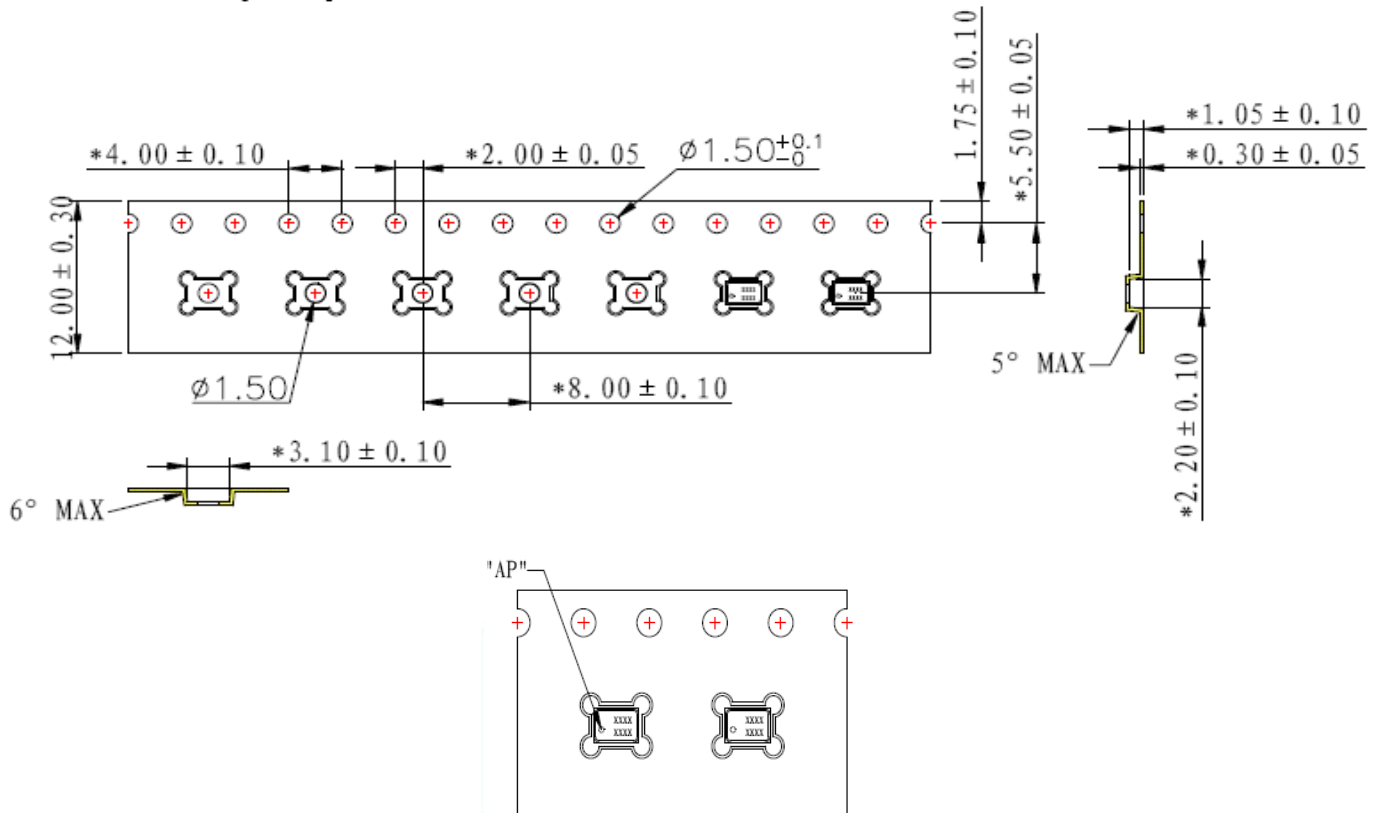

Figure 4. Recommended interface circuit for customers' applications

10.PACKAGING SPECIFICATIONS



Notes:

- (1) Dimensions are in millimeters unless otherwise specified;
- (2) Tape & Reel Per EIA-481 standard;
- (3) Label applied to external package and direct to reel;
- (4) Shelf life: Twelve (12) months when devices are to be stored in factory supplied, unopened ESD moisture sensitive bag under maximum environmental conditions of 30°C, 70% R.H.

Order Part Number	Reel Diameter	Qty per Reel
GTM2718AB381WNB2	13"	5,000

Figure 5. Tape Specification

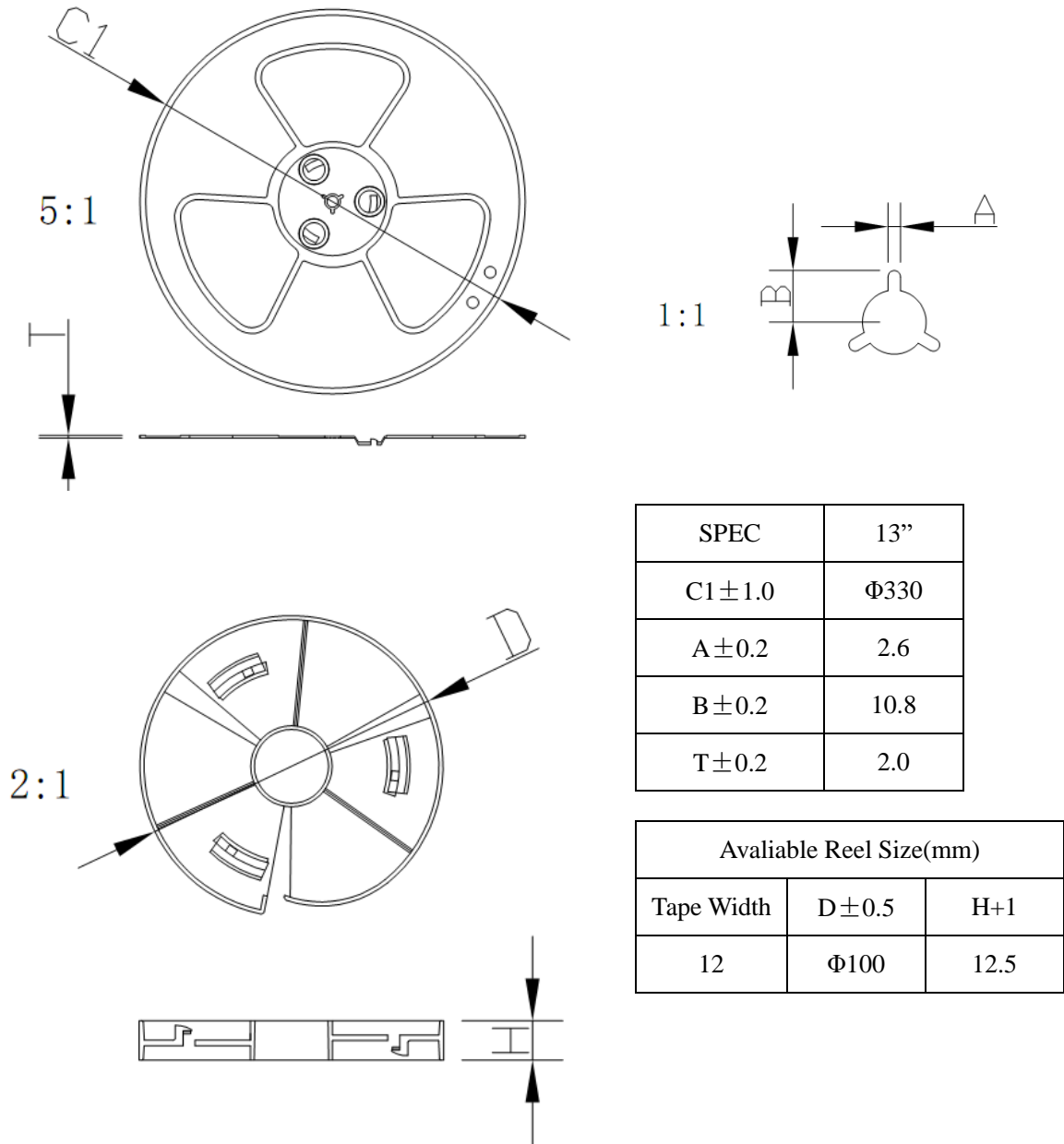

5,000 Pieces of Products per Reel

Figure 6. Reel Specification

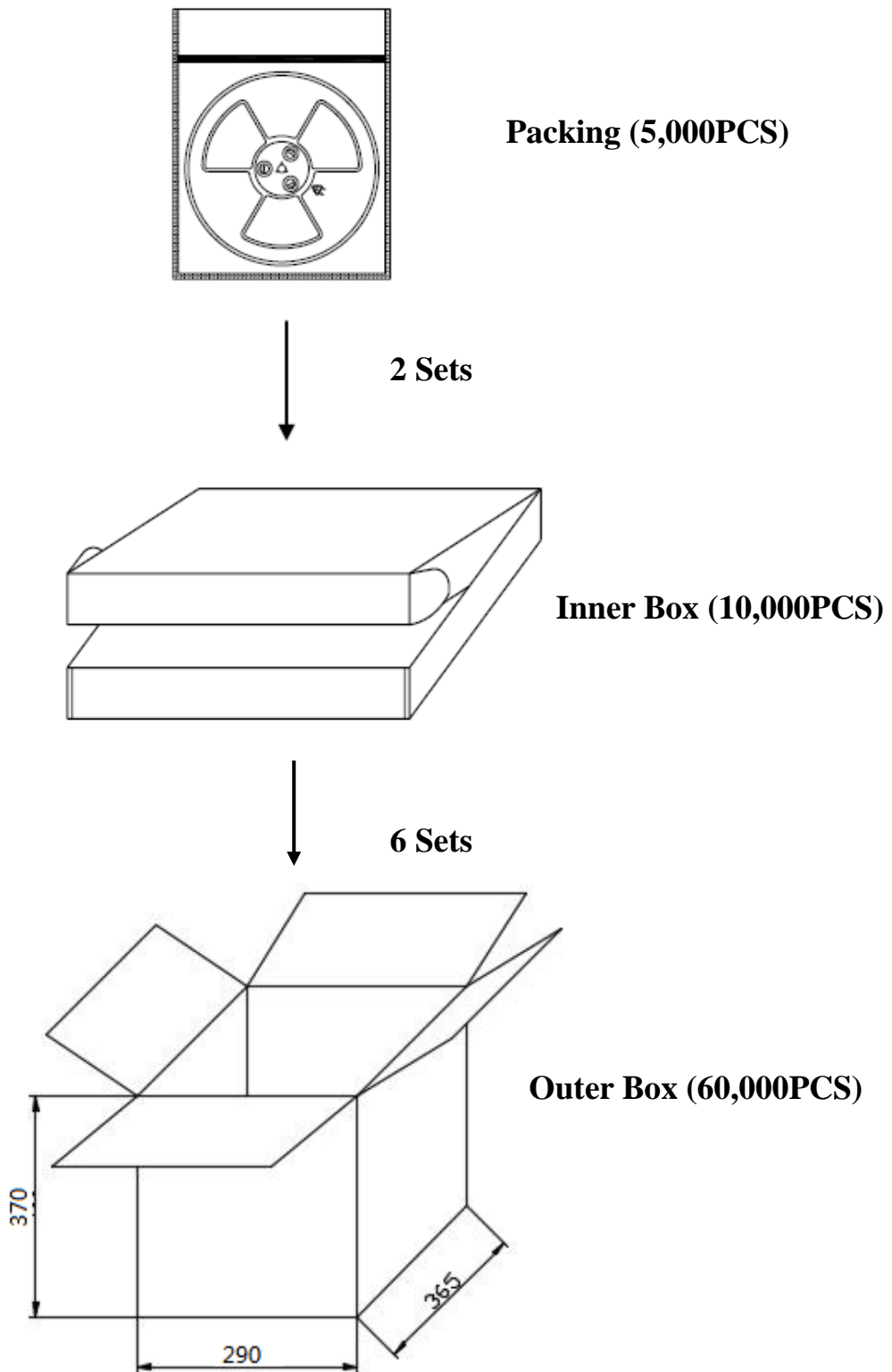

60,000 Pieces of Products per Carton

Figure 7. Packaging Specification



11.SOLDER REFLOW PROFILE

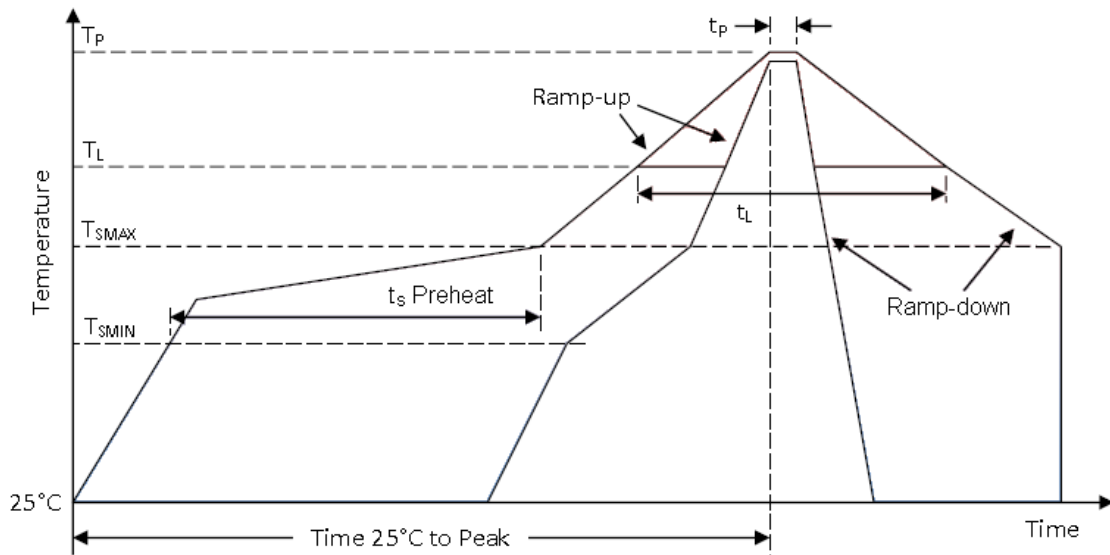

Profile Feature	Pb-Free
Average Ramp-up Rate (T_{SMAX} to T_P)	3°C/second max.
Preheat Temperature Min (T_{SMIN}) Temperature Max (T_{SMAX}) Time (T_{SMIN} to T_{SMAX}) (t_s)	150°C 200°C 60-180 seconds
Time maintained above: Temperature (T_L) Time (t_L)	217°C 60-150 seconds
Peak Temperature (T_P)	260°C
Time within 5°C of actual Peak Temperature (t_p)	20-40 seconds
Ramp-down Rate(T_P to T_{SMAX})	6°C/second max
Time 25°C to Peak Temperature	8 minutes max

Figure 8. Recommended leadless solder reflow temperature profile

Notes:

1. Vacuuming over acoustical hole of the microphone is not allowed, because the device can be damaged by vacuum.
2. Washing the board after reflow process is not allowed, because board washing and cleaning agents can damage the device. A device should not be exposed to ultrasonic processing or cleaning.
3. Recommended number of reflow is no more than 5 times.
4. Do not apply over 30 psi of air pressure into the port hole.
5. MSL (moisture sensitivity level) Class 1.

**12.RELIABILITY SPECIFICATIONS**

Test item	Detail	Standard
Reflow Simulation	Refer to Sec.9 for solder reflow profile, total 5 times	/
Low Temperature Bias	Conditions: -40°C Duration:168 hours while under bias	IEC 60068-2-2 Test Aa
High Temperature Bias	Conditions: 105°C Duration:168 hours while under bias	IEC 60068-2-2 Test Ba
Thermal Shock	Conditions: 100 cycles of air-air thermal shock from -40°C to 125°C with 15-minute soaks	IEC 60068-2-4
Temperature/Humidity Bias	Conditions: 85°C/85%RH environment while under bias for 168 hours	JESD 22-A101A-B
Mechanical Shock	Conditions:3 pulses of 10,000g in the X,Y and Z direction	IEC 60068-2-27 Test Ea
Vibration Test	Test axis: X,Y,Z Conditions: 2~400Hz 1 oct/min Test time: 15 mins per axis Use fixture during the testing	IEC 60068-2-6
Drop Test	Conditions: For each sample, drop by all corners, edges, surfaces respectively. Steel floor. Drop height: 1800mm.	IEC 60068-2-32
ESD	Conditions: ±8KV direct contact to the lid when unit is grounded, ±4KV direct contact to the I/O pins.10 times	IEC 61000-4-2

Note:

Immediately after reliability test, the samples shall be stored under climatic conditions such as that normally exist in ordinary rooms or laboratories. Unless otherwise noted, the recovery period shall be 2 hours at least before performance testing. After test condition is performed, the sensitivity of the microphone shall not deviate more than 3dB from its initial value.



13. REVISION HISTORY:

Version	Date	Description
1.0	3/15/2021	Initial Release

Disclaimer: The information contained in this literature is based on our experience to date and is believed to be reliable and it is subject to change without notice. It is intended as a guide for use by persons having technical skills at their own discretion and risk. We do not guarantee favorable results or assume any liability in connection with its use. Dimensions contained herein are for reference purposes only. For specific dimensional requirements consult factory. This publication is not to be taken as a license to operate under, or recommendation to infringe any existing patents. This document supersedes and voids all previous literature on the same product.