

0.750" DIAMETER FLANGE MOUNT, SHORT TRAVEL



Conical Hat Shown

Standard Characteristics/Ratings:

ELECTRICAL RATINGS:

Insulation Resistance:	100MΩ min @ 50VDC
Null Temp Coefficient:	+/- 0.04% of full scale per degree C max
Hysteresis:	+/- 0.5% of full scale within 1 second after release
Sensitivity Temp Coefficient:	+/- 0.2% full scale per degree C
Resolution:	Infinite
Seal:	Enclosure dusttight per MIL-PRF-8805 Design 2
Operating Force:	3.0 lbs.
Operating Temp Range:	-40°C to +71°C
Storage Temp Range:	-55°C to +85°C
Travel:	To mechanical stop 0.05 inches max

MATERIALS:

Button:	Thermoplastic or anodized aluminum
Terminals:	Tin plate over copper plate over brass
Wire:	MIL-W-16878/4, 12 inches min, 24 AWG
Hardware:	None provided

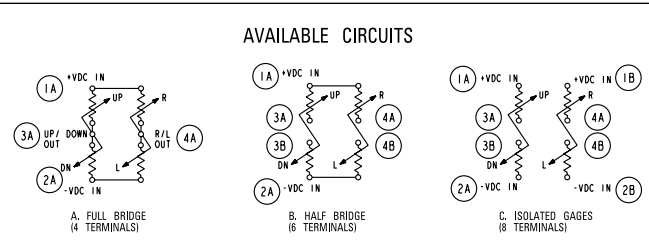
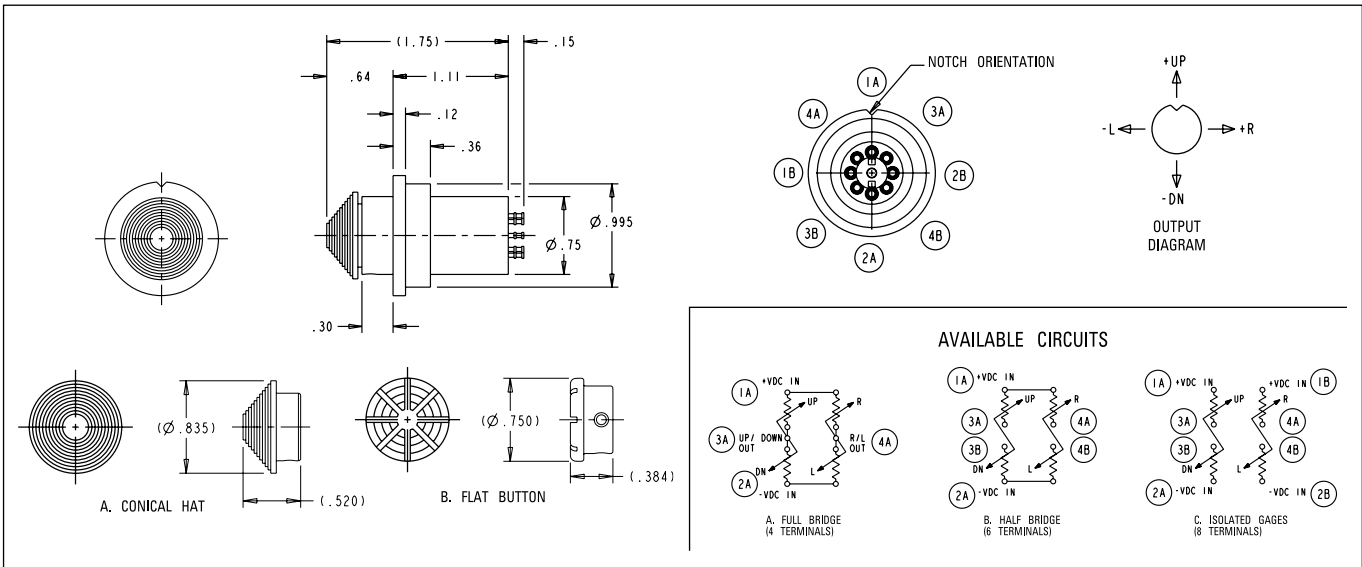

J2-S1 PART NUMBER CODE

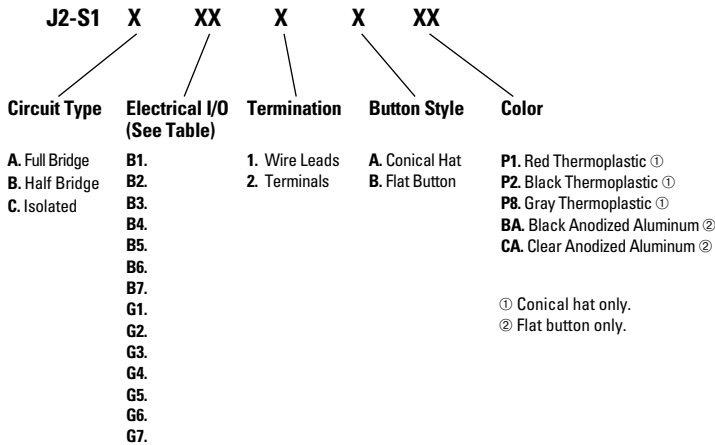

EXCITATION VOLTAGE TABLE						
Circuit Configuration	Excitation Voltage (Units VDC)	Sensitivity Until Stop (Units VDC/lb. +/- 20%)	Max Output at Stop (Units VDC)	Null Output at 25°C Bipolar (Units VDC)	Null Output at 25°C Supply to Ground (Units VDC)	Full Scale Travel Cycles (Units x 10 ⁶)
B1	+/- 12.0	+/- 0.45	+/- 1.40	+/- 0.12		0.2
G1	+24.0	+/- 0.45	+/- 1.40		12.0 +/- 0.12	0.2
B2	+/- 10.0	+/- 0.45	+/- 1.40	+/- 0.12		0.2
G2	+20.0	+/- 0.45	+/- 1.40		10.0 +/- 0.12	0.2
B3	+/- 7.5	+/- 0.45	+/- 1.40	+/- 0.10		0.3
G3	+15.0	+/- 0.45	+/- 1.40		7.5 +/- 0.10	0.3
B4	+/- 6.0	+/- 0.45	+/- 1.40	+/- 0.10		0.2
G4	+12.0	+/- 0.45	+/- 1.40		6.0 +/- 0.10	0.2
B5	+/- 6.0	+/- 0.33	+/- 1.03	+/- 0.06		1.0
G5	+12.0	+/- 0.33	+/- 1.03		6.0 +/- 0.06	1.0
B6	+/- 5.0	+/- 0.33	+/- 1.03	+/- 0.05		1.0
G6	+10.0	+/- 0.33	+/- 1.03		5.0 +/- 0.05	1.0
B7	+/- 5.0	+/- 0.25	+/- 0.78	+/- 0.05		2.0
G7	+10.0	+/- 0.25	+/- 0.78		5.0 +/- 0.05	2.0

0.655" DIAMETER FLANGE MOUNT, SHORT TRAVEL



Flat Button Shown

Standard Characteristics/Ratings:

ELECTRICAL RATINGS:

Insulation Resistance:	100MΩ min @ 50VDC
Null Temp Coefficient:	+/- 0.04% of full scale per degree C max
Hysteresis:	+/- 0.5% of full scale within 1 second after release
Sensitivity Temp Coefficient:	+/- 0.2% full scale per degree C
Resolution:	Infinite
Seal:	Enclosure dusttight per MIL-PRF-8805 Design 2
Operating Force:	3.0 lbs.
Operating Temp Range:	-40°C to +71°C
Storage Temp Range:	-55°C to +85°C
Travel:	To mechanical stop 0.05 inches max

MATERIALS:

Button:	Thermoplastic or anodized aluminum
Terminals:	Tin plate over copper plate over brass
Wire:	MIL-W-16878/4, 12 inches min, 24 AWG
Hardware:	None provided



J2-S2 PART NUMBER CODE

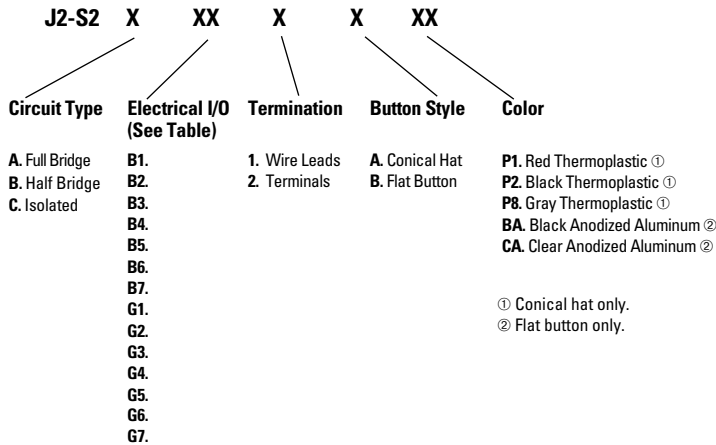

Circuit Configuration	Excitation Voltage (Units VDC)	Sensitivity Until Stop (Units VDC/lb. +/- 20%)	Max Output at Stop (Units VDC)	Null Output at 25°C Bipolar (Units VDC)	Null Output at 25°C Supply to Ground (Units VDC)	Full Scale Travel Cycles (Units x 10 ⁶)
B1	+/- 12.0	+/- 0.45	+/- 1.40	+/- 0.12		0.2
G1	+ 24.0	+/- 0.45	+/- 1.40		12.0 +/- 0.12	0.2
B2	+/- 10.0	+/- 0.45	+/- 1.40	+/- 0.12		0.2
G2	+ 20.0	+/- 0.45	+/- 1.40		10.0 +/- 0.12	0.2
B3	+/- 7.5	+/- 0.45	+/- 1.40	+/- 0.10		0.3
G3	+ 15.0	+/- 0.45	+/- 1.40		7.5 +/- 0.10	0.3
B4	+/- 6.0	+/- 0.45	+/- 1.40	+/- 0.10		0.2
G4	+ 12.0	+/- 0.45	+/- 1.40		6.0 +/- 0.10	0.2
B5	+/- 6.0	+/- 0.33	+/- 1.03	+/- 0.06		1.0
G5	+ 12.0	+/- 0.33	+/- 1.03		6.0 +/- 0.06	1.0
B6	+/- 5.0	+/- 0.33	+/- 1.03	+/- 0.05		1.0
G6	+ 10.0	+/- 0.33	+/- 1.03		5.0 +/- 0.05	1.0
B7	+/- 5.0	+/- 0.25	+/- 0.78	+/- 0.05		2.0
G7	+ 10.0	+/- 0.25	+/- 0.78		5.0 +/- 0.05	2.0

0.560" DIAMETER FLANGE MOUNT, SHORT TRAVEL

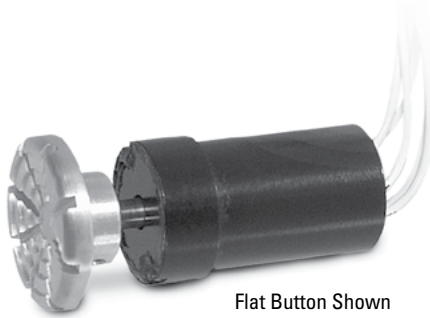

Flat Button Shown

Standard Characteristics/Ratings:

ELECTRICAL RATINGS:

Insulation Resistance:	100MΩ min @ 50VDC
Null Temp Coefficient:	+/- 0.04% of full scale per degree C max
Hysteresis:	+/- 0.5% of full scale within 1 second after release
Sensitivity Temp Coefficient:	+/- 0.2% full scale per degree C
Resolution:	Infinite
Seal:	Enclosure dusttight per MIL-PRF-8805 Design 2
Operating Force:	3.0 lbs.
Operating Temp Range:	-40°C to +71°C
Storage Temp Range:	-55°C to +85°C
Travel:	To mechanical stop 0.05 inches max

MATERIALS:

Wire:	MIL-W-16878/4, 12 inches min 24 AWG
Button:	Thermoplastic or anodized aluminum
Hardware:	None provided

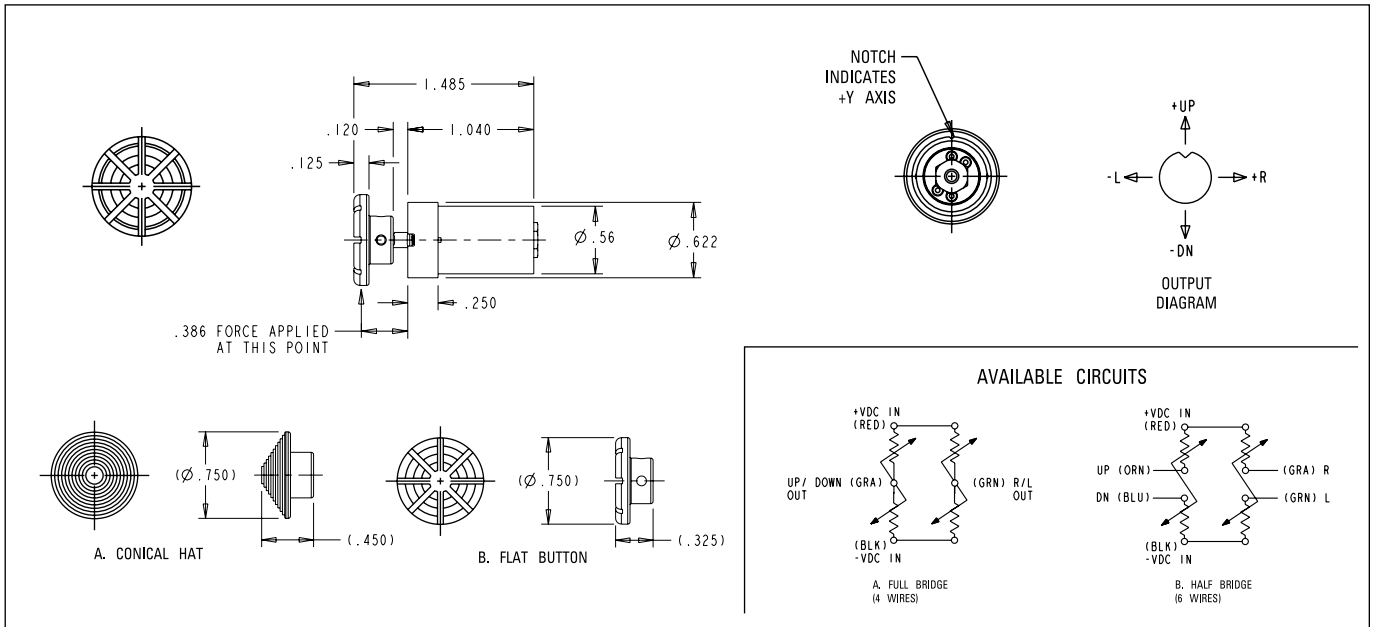

J2-S3 PART NUMBER CODE

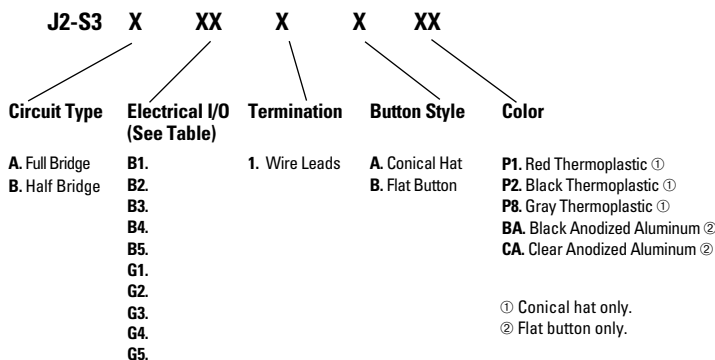

Circuit Configuration	Excitation Voltage (Units VDC)	Sensitivity Until Stop (Units VDC/lb. +/- 20%)	Max Output at Stop (Units VDC)	Null Output at 25°C Bipolar (Units VDC)	Null Output at 25°C Supply to Ground (Units VDC)	Full Scale Travel Cycles (Units x 10 ⁶)
B1	+/- 7.5	+/- 0.45	+/- 1.40	+/- 0.10		0.3
G1	+ 15.0	+/- 0.45	+/- 1.40		7.5 +/- 0.10	0.3
B2	+/- 6.0	+/- 0.45	+/- 1.40	+/- 0.10		0.2
G2	+ 12.0	+/- 0.45	+/- 1.40		6.0 +/- 0.10	0.2
B3	+/- 6.0	+/- 0.33	+/- 1.03	+/- 0.06		1.0
G3	+ 12.0	+/- 0.33	+/- 1.03		6.0 +/- 0.06	1.0
B4	+/- 5.0	+/- 0.33	+/- 1.03	+/- 0.05		1.0
G4	+ 10.0	+/- 0.33	+/- 1.03		5.0 +/- 0.05	1.0
B5	+/- 5.0	+/- 0.25	+/- 0.78	+/- 0.05		2.0
G5	+ 10.0	+/- 0.25	+/- 0.78		5.0 +/- 0.05	2.0