



T201213 Series



1. Features of T201213 Series :

- Meets medical safety isolation requirements.
- Designed for frequencies from 20KHz to 300KHz.
- Available in UL Class B (130°C) Versions .
- Ideal for Gate Drive Transformer, Signal Transformer Across Isolation Barrier , Off-Line AC/DC Converters and High-powered DC/DC Converters.
- Operating temperature range: -40° C to +130° C .
- RoHS & HF compliance Components.

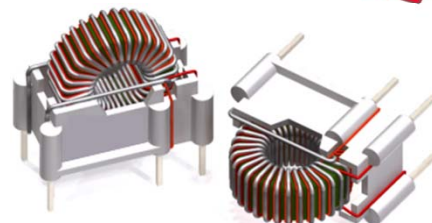

2.1 Electrical Characteristic of T201213 Series – Standard Versions (High withstand voltage):

| ITG Part Number | Turns Ratio | Primary inductance PIN(1-6) (mH, Min.) | Leakage Inductance PIN(1-6) (nH, Max.) | DC Resistance mΩ (Max) @25°C | | | ET (V-us) | Hi-pot (Drive to Gate) |
|-----------------|--------------|--|--|---------------------------------|--------|--------|--------------|---------------------------|
| | Drive : Gate | | | Drive | Gate | Gate | | |
| T201213-1H-x | 1:1:1 | 2.70 ± 25% | 1000.0 | 300.0 | 300.0 | 300.0 | 157.0 | 4500V _{DC} |
| T201213-2H-x | 1:1:1 | 0.247 | 200.0 | 40.0 | 40.0 | 40.0 | 63.0 | 4500V _{DC} |
| T201213-3H-x | 1:1:1 | 0.450 | 500.0 | 100.0 | 100.0 | 100.0 | 95.0 | 4500V _{DC} |
| T201213-4H-x | 1:1:1 | 0.686 | 800.0 | 780.0 | 780.0 | 780.0 | 115.0 | 4500V _{DC} |
| T201213-5H-x | 1:1:1 | 0.990 | 400.0 | 70.0 | 70.0 | 70.0 | 126.0 | 4500V _{DC} |
| T201213-6H-x | 1:1:1 | 2.220 | 500.0 | 200.0 | 200.0 | 200.0 | 189.0 | 4500V _{DC} |
| T201213-7H-x | 1:1:1 | 3.960 | 700.0 | 500.0 | 500.0 | 500.0 | 252.0 | 4500V _{DC} |
| T201213-8H-x | 1:1:1 | 6.180 | 800.0 | 1000.0 | 1000.0 | 1000.0 | 315.0 | 4500V _{DC} |
| T201213-9H-x | 1:1:1 | 8.910 | 1200.0 | 2700.0 | 2700.0 | 2700.0 | 378.0 | 4500V _{DC} |
| T201213-10H-x | 1:2.5:2.5 | 0.039 | 150.0 | 20.0 | 40.0 | 40.0 | 63.0 | 4500V _{DC} |
| T201213-11H-x | 1:2.5:2.5 | 0.158 | 200.0 | 40.0 | 70.0 | 70.0 | 126.0 | 4500V _{DC} |
| T201213-12H-x | 1:2.5:2.5 | 0.356 | 250.0 | 100.0 | 200.0 | 200.0 | 189.0 | 4500V _{DC} |
| T201213-13H-x | 1:2.5:2.5 | 0.634 | 300.0 | 200.0 | 450.0 | 450.0 | 252.0 | 4500V _{DC} |
| T201213-14H-x | 1:2.5:2.5 | 0.990 | 400.0 | 400.0 | 900.0 | 900.0 | 315.0 | 4500V _{DC} |
| T201213-15H-x | 1:2.5:2.5 | 1.420 | 500.0 | 1100.0 | 2500.0 | 2500.0 | 378.0 | 4500V _{DC} |

2.2 Electrical Characteristic of T201213 Series – Economy Versions (Low withstand voltage):

| ITG Part Number | Turns Ratio | Primary inductance PIN(1-6) (mH, Min.) | Leakage Inductance PIN(1-6) (nH, Max.) | DC Resistance mΩ (Max) @25°C | | | ET (V-us) | Hi-pot (Drive to Gate) |
|-----------------|--------------|--|--|---------------------------------|--------|--------|--------------|---------------------------|
| | Drive : Gate | | | Drive | Gate | Gate | | |
| T201213-1-x | 1:1:1 | 2.70 ± 25% | 1000.0 | 300.0 | 300.0 | 300.0 | 157.0 | 200V _{DC} |
| T201213-2-x | 1:1:1 | 0.247 | 200.0 | 40.0 | 40.0 | 40.0 | 63.0 | 200V _{DC} |
| T201213-3-x | 1:1:1 | 0.990 | 400.0 | 70.0 | 70.0 | 70.0 | 126.0 | 200V _{DC} |
| T201213-4-x | 1:1:1 | 2.220 | 500.0 | 200.0 | 200.0 | 200.0 | 189.0 | 200V _{DC} |
| T201213-5-x | 1:1:1 | 3.960 | 700.0 | 500.0 | 500.0 | 500.0 | 252.0 | 200V _{DC} |
| T201213-6-x | 1:1:1 | 6.180 | 800.0 | 1000.0 | 1000.0 | 1000.0 | 315.0 | 200V _{DC} |
| T201213-7-x | 1:1:1 | 8.910 | 1200.0 | 2700.0 | 2700.0 | 2700.0 | 378.0 | 200V _{DC} |
| T201213-8-x | 1:2.5:2.5 | 0.039 | 150.0 | 20.0 | 40.0 | 40.0 | 63.0 | 200V _{DC} |
| T201213-9-x | 1:2.5:2.5 | 0.158 | 200.0 | 40.0 | 70.0 | 70.0 | 126.0 | 200V _{DC} |
| T201213-10-x | 1:2.5:2.5 | 0.356 | 250.0 | 100.0 | 200.0 | 200.0 | 189.0 | 200V _{DC} |
| T201213-11-x | 1:2.5:2.5 | 0.634 | 300.0 | 200.0 | 450.0 | 450.0 | 252.0 | 200V _{DC} |
| T201213-12-x | 1:2.5:2.5 | 0.990 | 400.0 | 400.0 | 900.0 | 900.0 | 315.0 | 200V _{DC} |
| T201213-13-x | 1:2.5:2.5 | 1.420 | 500.0 | 1100.0 | 2500.0 | 2500.0 | 378.0 | 200V _{DC} |

● New York 1 914 347 2474 ● Taipei 886 2 2698 8669 ● Kaohsiung 886 7 350 2275
 ● Japan 81 568 85 2830 ● Shenzhen 86 755 8418 6263 ● Shanghai 86 21 5424 5141 ● Hong Kong 852 9688 9767
 ● sales@ITG-Electronics.com ● www.ITG-Electronics.com Revision A.0: August 30, 2019

*Due to continuous product improvement, all specifications are subject to change without prior notice. Kindly contact an ITG field application engineer or a sales representative prior to purchase.

T201213 Series



3. Mechanical Dimension(Unit : mm):

| A | B | C | D | E1 | E2 | E3 | F |
|-------|-------|--------|-------|--------|--------|--------|----------------|
| Max. | Max. | ± 0.30 | Max. | ± 0.50 | ± 0.50 | ± 0.50 | Nom. |
| 20.57 | 12.19 | 3.50 | 19.05 | 5.08 | 8.89 | 17.78 | □0.64* 0.64 |

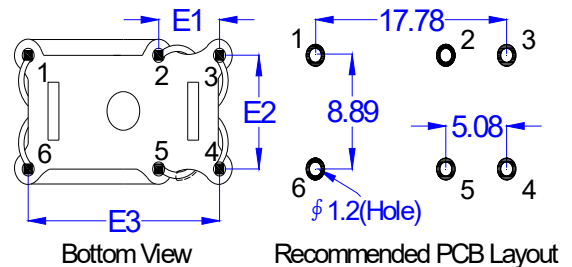
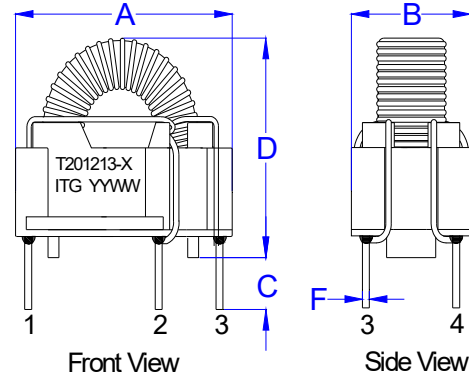

4. SCHEMATIC DIAGRAM:

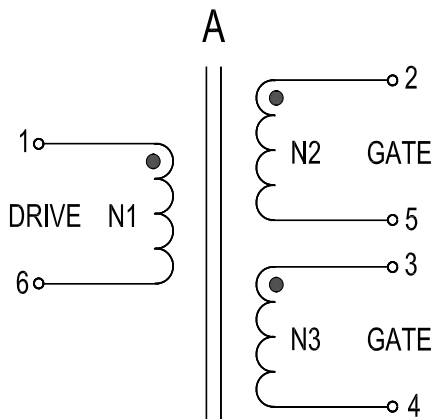

Notes: " • " Start of Winding

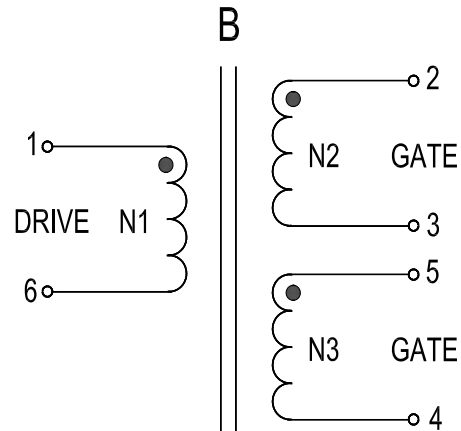

Notes: " • " Start of Winding

Notes:

- 1>. The suffix "x" =A or B stands for Schematic A or Schematic B.
- 2>. Open Circuit Inductance (OCL) test condition: 10KHz , 100mVrms , 0Adc ,at 25 °C.
- 3>. Electrical specifications at 25°C.
- 4>. Meets UL 94V-0.
- 5>. E-T product rating is for secondary(gate)windings and is based upon flux density of 2200 gauss at 25°C in a bipolar drive applications.
- 6>. Select pin assignment option based on schematics above. For other options, please contact ITG.
- 7>. Packaging: 42pcs/1Tray, 588pcs/1Carton.

● New York 1 914 347 2474 ● Taipei 886 2 2698 8669 ● Kaohsiung 886 7 350 2275
● Japan 81 568 85 2830 ● Shenzhen 86 755 8418 6263 ● Shanghai 86 21 5424 5141 ● Hong Kong 852 9688 9767
● sales@ITG-Electronics.com ● www.ITG-Electronics.com Revision A.0: August 30, 2019

*Due to continuous product improvement, all specifications are subject to change without prior notice. Kindly contact an ITG field application engineer or a sales representative prior to purchase.