

High Efficiency Boost 2P8S/3P8S LED Driver

Features

- KTD3116-1: 2 strings, 16 LEDs total
- KTD3117-1: 3 strings, 24 LEDs total
- High efficiency: up to 90%
- High frequency step-up converter (800kHz)
- Wide input range: 2.7V to 5.5V
- Integrated 40V Power MOSFET
- Internal compensation and soft start
- Integrated 2- or 3-channel current sink
- Preset 20mA full-scale current per channel
- 1.5% Typ. current matching
- PWM dimming with < 0.3 μ s rise/fall time
- Low quiescent current
- LED open/short protection
- 31V LED open-circuit (OVP) threshold
- Cycle-by-cycle inductor current limit
- < 1 μ A shutdown current
- Pb-free Package:
WLCSP-9 1.2mm x 1.2mm
- -40°C to +85°C Temperature Range

Applications

- Smartphone
- PDA
- GPS
- Portable media players
- Other 1-cell Li Ion LED applications

Brief Description

KTD3116-1/KTD3117-1 is the ideal power solution for white LED backlighting used with medium to small size LCD panels. It is a highly integrated step up DC-DC converter with input voltage range from 2.7V to 5.5V, accommodating 1-cell lithium ion battery or 5V regulated supply. KTD3116/7-1 integrates a 40V Power MOSFET as well as compensation and soft start circuitry, which results in a simpler and smaller solution with much fewer external components. High switching frequency (800kHz) allows the use of a smaller inductor and capacitor to further reduce the solution size.

Two regulated current sinks in KTD3116-1 and three sinks in KTD3117-1 provide per channel 20mA (max.) factory programmed current. With a 31V OVP, each string can connect up to eight LEDs in series, for a total of 16 or 24 LEDs in KTD3116-1 and KTD3117-1 respectively.

A PWM dimming control is included for wide output current range. The device has an EN pin which enables the IC.

Various protection features are built into KTD3116/7-1, including cycle-by-cycle input current limit protection, output over-voltage protection, LED fault (open or short) protection and thermal shutdown protection. The leakage current in shutdown mode is less than 1 μ A.

KTD3116/7-1 is available in a RoHS compliant and Green 9-lead 1.2mm x 1.2mm WLCSP package.

Typical Application

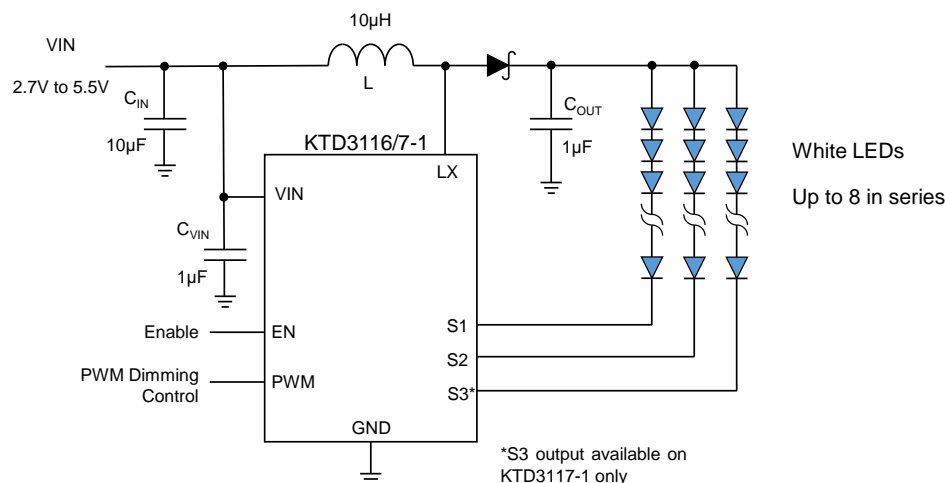

Pin Descriptions

Pin #		Name	Function
KTD3116-1	KTD3117-1		
B1	B1	LX	Switching node of the step-up converter
A2	A2	PWM	Pulse width controlled dimming input. Connect this pin to VIN when not used. There is an internal 400kΩ pull-down resistor at this pin.
C3	C3	NC	Not internally connected
A1	A1	EN	IC enable pin. There is an internal 400kΩ pull-down resistor at this pin.
B2, C1	C1	GND	Analog Ground pin. All GND pins must be connected in the PCB for proper operation.
N/A	B2	S3	Regulated output current sink #3
B3	B3	S2	Regulated output current sink #2
A3	A3	S1	Regulated output current sink #1
C2	C2	VIN	Input supply pin for the IC

KTD3116-1 WLCSP-9, 1.2mm x 1.2mm
(Top View)

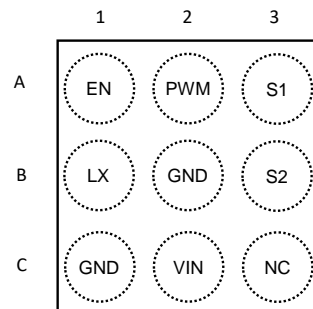

KTD3117-1 WLCSP-9, 1.2mm x 1.2mm
(Top View)

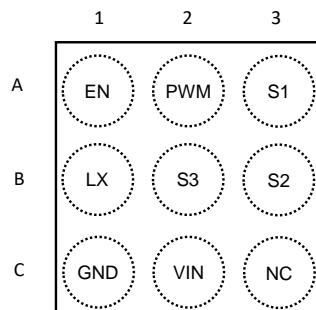

Absolute Maximum Ratings¹

(T_A = 25°C unless otherwise noted)

Symbol	Description	Value	Units
V _{IN}	Input voltage	-0.3 to 6	V
L _X	High voltage node	-0.3 to 40	V
S _x	High voltage node	-0.3 to 22	V
EN, PWM	Control pins	-0.3 to V _{IN} +0.3	V
T _J	Operating Temperature Range	-40 to 150	°C
T _s	Storage Temperature Range	-65 to 150	°C
T _{LEAD}	Maximum Soldering Temperature (at leads, 10 sec)	300	°C

Thermal Capabilities

Symbol	Description	Value	Units
WLCSP-9			
θ _{JA}	Thermal Resistance – Junction to Ambient ²	100	°C/W
PD	Maximum Power Dissipation at T _A = 25°C	1.1	W
ΔP _D /ΔT	Derating Factor Above T _A = 25°C	-10.0	mW/°C

Ordering Information

Part Number	Max. Sink Current (nominal)	Marking ³	Operating Temperature	Package
KTD3116EAA-20-1-TR	20mA	ISYYZ	-40°C to +85°C	WLCSP-9 1.2x1.2mm
KTD3117EAA-20-1-TR	20mA	__YYZ	-40°C to +85°C	WLCSP-9 1.2x1.2mm

1. Stresses above those listed in Absolute Maximum Ratings may cause permanent damage to the device. Functional operation at conditions other than the operating conditions specified is not implied. Only one Absolute Maximum rating should be applied at any one time.

2. Junction to Ambient thermal resistance is highly dependent on PCB layout. Values are based on thermal properties of the device when soldered to an EV board.

3. "YYZ" is the date code and assembly code.

Electrical Characteristics⁴

Unless otherwise noted, the *Min* and *Max* specs are applied over the full operation temperature range of -40°C to $+85^{\circ}\text{C}$, while *Typ* values are specified at room temperature (25°C). $V_{\text{IN}} = 3.6\text{V}$,

Symbol	Description	Conditions	Min	Typ	Max	Units
IC Supply						
V_{IN}	Input operating range		2.7		5.5	V
UVLO	Input under voltage lockout	Rising edge		2.5	2.65	V
UVLO _{HYST}	UVLO hysteresis			0.15		V
I_{Q}	IC standby current	Not switching		0.65		mA
	IC operating current	Switching		1.5		mA
I_{SHDN}	VIN pin shutdown current	EN = GND			1.0	μA
Step-Up Converter						
$R_{\text{DS(ON)}}$	NMOS on-resistance			0.35		Ω
I_{LM}	Peak NMOS current limit			1.5		A
$I_{\text{INRUSH-SU}}$	Peak Inductor Current During Startup	$V_{\text{IN}} = 3.6\text{V}$, 2p8s LEDs, $I_{\text{LED}} = 20\text{mA}$, $L = 10\mu\text{H}$, $C_{\text{OUT}} = 1\mu\text{F}$		700		mA
F_{SW}	Oscillator frequency			800		kHz
D_{max}	Maximum duty cycle		92	95		%
OVP	Over voltage threshold	Measured at LX pin		31		V
Current Sink						
I_{D}	Output current accuracy	Current setting = 20mA (Duty Cycle 100%)		± 2		%
	Output current matching ⁵	Current setting = 20mA (Duty Cycle 100%)		1.5		%
V_{SOV}	Current sink over voltage threshold			6.7		V
T_{FAULT}	Current sink Fault Delay			80		ms
Control						
$V_{\text{TH-L}}$	EN, PWM pin logic low threshold				0.4	V
$V_{\text{TH-H}}$	EN, PWM pin logic high threshold		1.4			V
R_{EN}	EN pin pull-down resistor			400		k Ω
R_{PWM}	PWM pin pull-down resistor			400		k Ω
F_{PWM}	PWM dimming frequency		100		30000	Hz
$t_{\text{PWM(ON)}}$	PWM dimming on-time		0.5			μs
$T_{\text{J-TH}}$	IC junction thermal shutdown threshold			150		$^{\circ}\text{C}$
	IC junction thermal shutdown hysteresis			15		$^{\circ}\text{C}$

4. KTD3116-1 is guaranteed to meet performance specifications over the -40°C to $+85^{\circ}\text{C}$ operating temperature range by design, characterization and correlation with statistical process controls.

5. The current matching between channels is defined as $|I_{\text{d}} - I_{\text{avg}}|_{\text{max}} / I_{\text{avg}}$.

Typical Characteristics

$V_{IN} = 3.6V$, $L = 10\mu H$, $C_{IN} = 10\mu F$, $C_{VIN} = 1\mu F$, $C_{OUT} = 1\mu F$ with 2P8S LEDs in series at 20mA, $T_{AMB} = 25^{\circ}C$ unless otherwise specified.

Efficiency vs. Input Voltage

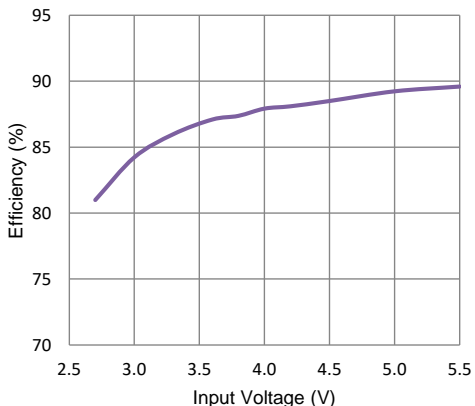

Efficiency vs. LED Current

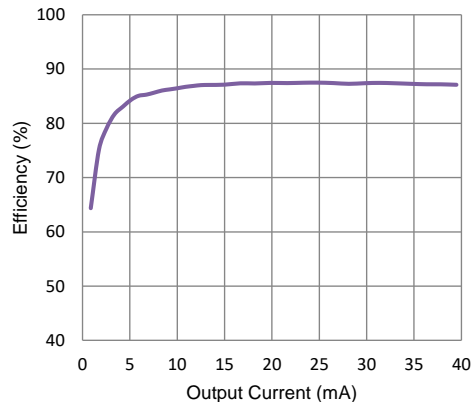

Operating Current (non-switching)

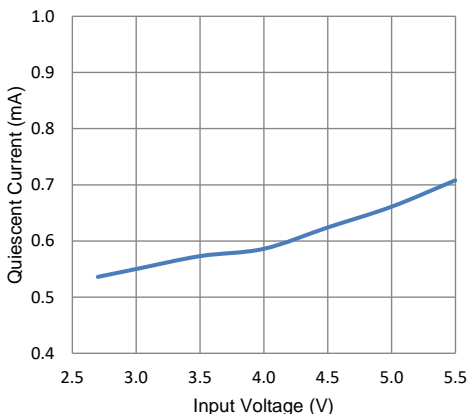

Operating Current (switching)

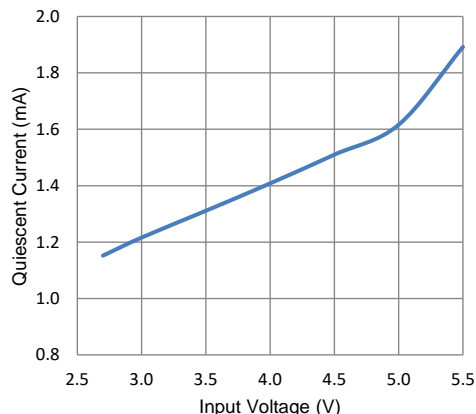

Switching Frequency

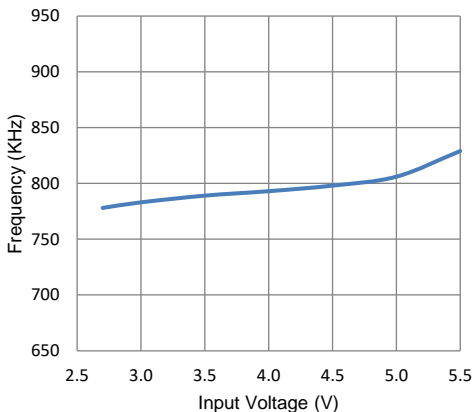

EN Logic Threshold Voltage

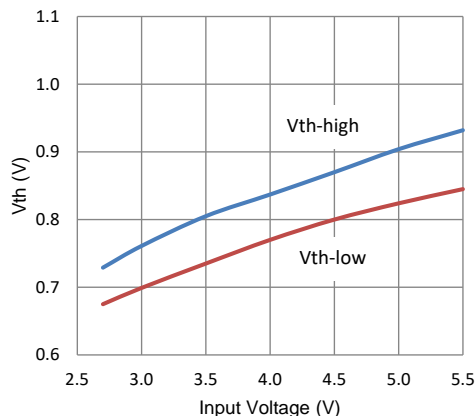

Typical Characteristics (continued)

$V_{IN} = 3.6V$, $L = 10\mu H$, $C_{IN} = 10\mu F$, $C_{VIN} = 1\mu F$, $C_{OUT} = 1\mu F$ with 2P8S LEDs in series at 20mA, $T_{AMB} = 25^{\circ}C$ unless otherwise noted.

Soft-Start Turn On

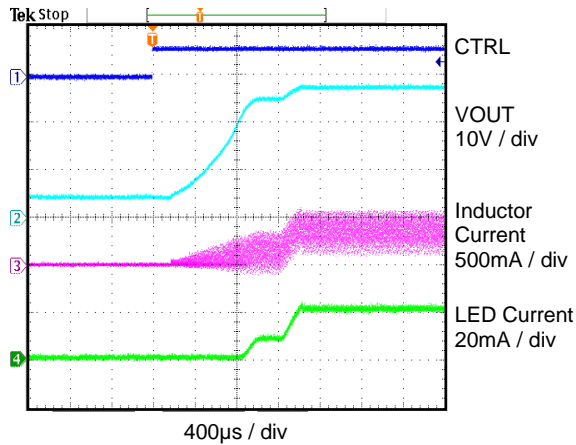

Soft-Start Turn Off

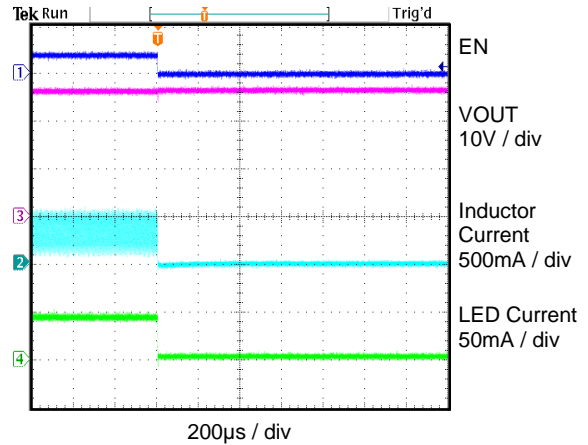

Steady State Switching

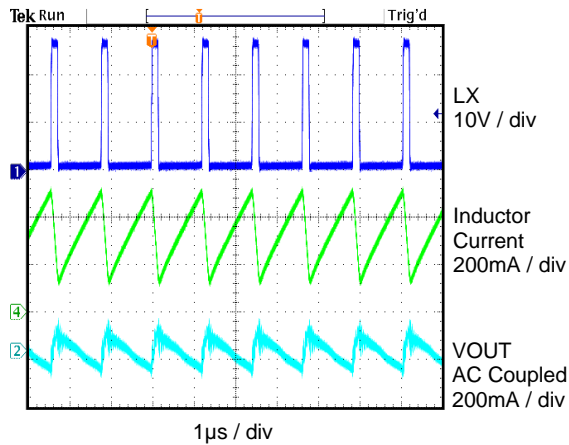

Turn On with LED Open (OVP)

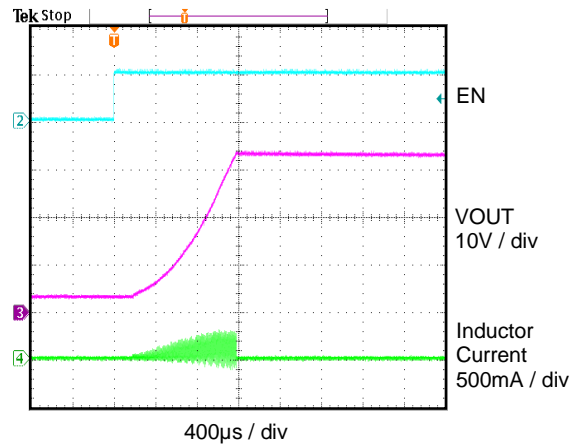

PWM Dimming at 20kHz

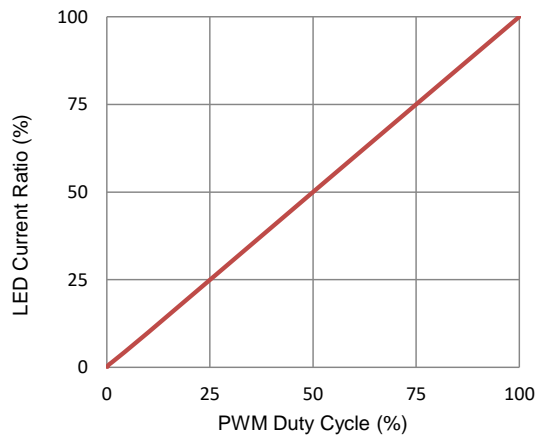

Typical Characteristics (continued)

$V_{IN} = 3.6V$, $L = 10\mu H$, $C_{IN} = 10\mu F$, $C_{OUT} = 1\mu F$ with 2P8S LEDs in series at 20mA, $T_{AMB} = 25^{\circ}C$ unless otherwise specified.

PWM Dimming at 200Hz

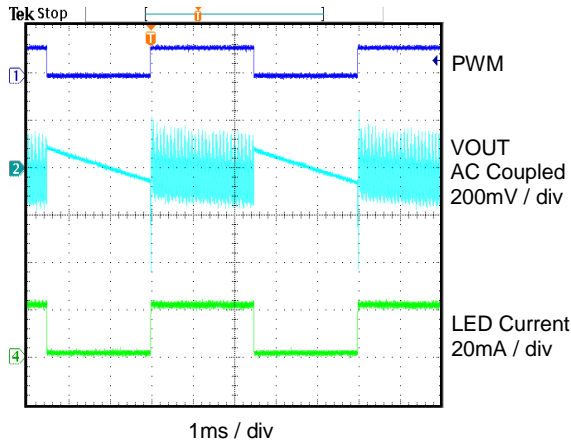

PWM Dimming at 20kHz

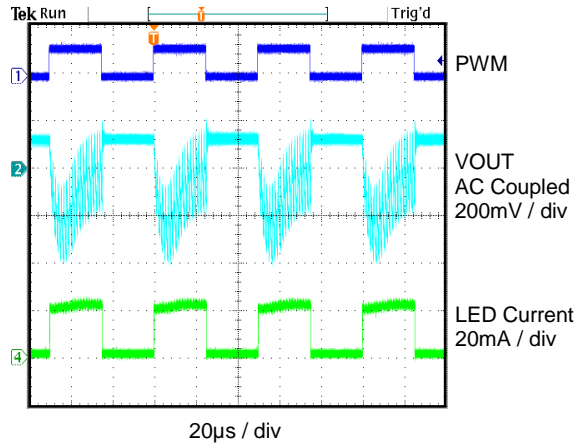

Functional Block Diagram

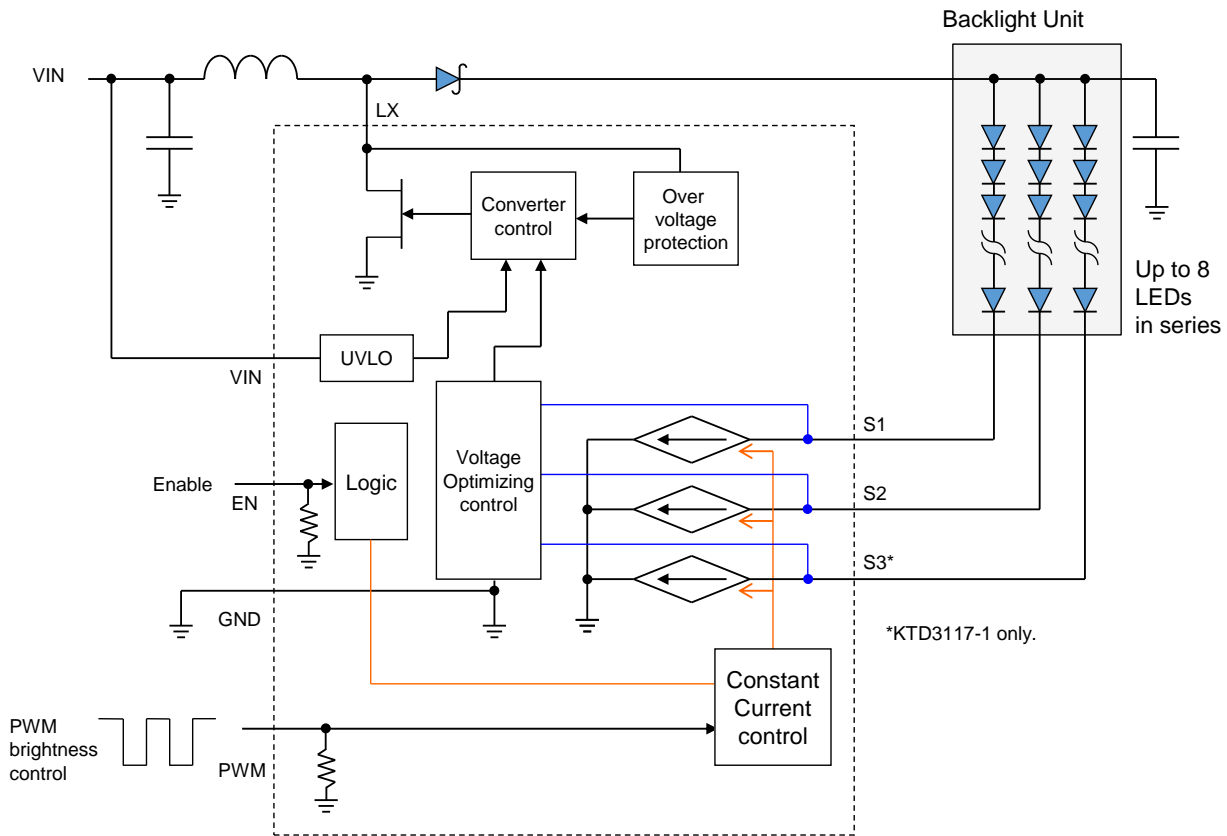

Functional Description

The KTD3116-1 are current regulated step-up (boost) converters which respectively can drive two or three strings of LEDs. Unused channels, if any, need to be connected to ground (GND).

The voltage step-up is accomplished by a boost topology, using an inductor-based DC-DC switching converter, in which the inductor serves as an energy storage device in the system. By integrating a high voltage optimized MOSFET, KTD3116-1 internal switching frequency is 800kHz while still maintaining high power efficiency. Unlike a traditional DC-DC boost converter with a fixed output voltage, KTD3116-1 dynamically changes its output voltage regulation parameters depending on the load. The use of unique control schemes maintains accurate current regulation in each of the current sinks while leaving the output voltage at a minimum, increasing the overall conversion efficiency. The internal step-up converter dynamically controls the voltage at the output high enough to drive the LED string with the highest total forward voltage.

PWM pulses provided at PWM pin program the sink's on and off, so that the average LED current is proportional to the PWM duty cycle. Asserting a logic high on EN pin turns each output sink to maximum LED current. LED dimming is based on the popular PWM dimming scheme which is supported via the PWM pin.

Application Information

Current Dimming using PWM Pin

KTD3116/7-1 allows maximum flexibility with a PWM signal control input which can be used for dimming. The IC must remain Enabled at ENpin during PWM dimming. Each LED channel can typically recover from no current within 0.3 μ s. This allows very short PWM on-time or a duty-cycle with fine resolution. Assume a 50 μ s minimum on-time for a 100Hz PWM signal, a 200:1 ratio can be achieved by PWM.

In order to guarantee a soft-start during start-up, the EN input should always transition from low to high during power-up. If the EN input is kept high while PWM operates in burst mode, the soft-start is no longer supported resulting in some inrush current during subsequent power-ups.

Fault Protection

Each current sink is protected against LED short or open conditions. If an LED short circuit condition arises, the current sink continues to regulate until $V_{SINK} > V_{SOV}$. When any sink node voltage goes above V_{SOV} (6.7V) for more than 80ms (while PWM dimming signal remains high), that channel's current sink will be turned off, and other channels will still work if they don't trigger this fault condition. For example, if one or more LEDs on a channel are shorted, that channel's sink voltage will increase. If the voltage goes above 6.7V for more than 80ms, the Current Sink Fault Protection will be triggered and only this faulty string will be disabled by shutting off this current sink. All other channels will continue normal operation if they don't have a fault condition. When PWM dimming control is used, the 80ms fault delay is accumulated only when PWM signal is high; the PWM low time is not counted into the fault delay, so the delay time will be 80ms/ D_{PWM} (D_{PWM} is the duty cycle of the PWM signal).

In case of an LED failing open, the current sink voltage of the failed string will go close to ground and dominate the boost converter control loop. As a result the output voltage will move up to the over-voltage threshold. KTD3116-1 uses LX pin to sense the output over voltage. Once the over-voltage incident is flagged internally, the faulty channel(s) will be disabled. Then the output voltage of the boost converter will go back to normal level. During the entire process, the rest of the LED strings (healthy LED strings) would continue normal operation.

The fault conditions are reset by toggling EN pin or power on reset.

Thermal Shutdown

Thermal shutdown feature is included in the KTD3116/7-1. When the IC's junction temperature (T_J) reaches 150°C, the IC will immediately enter shutdown mode. Once T_J drops 15°C to approximately 135°C, the IC will resume normal operation.

Inductor Selection

A 10 μ H inductor is recommended for all applications. If high efficiency is a critical requirement, a low DCR inductor should be selected. The inductor's saturation current rating should also exceed the peak input current.

Table 1. Recommended Inductors

Application	Inductor Part Number	Value (μ H)	DCR (Ω)	Saturation Current (A)	Dimensions (mm)	Manufacturer
2P8S or 3P8S LEDs	VLCF5020T-100MR	10	0.182 max	1.13	5x5x2.0	TDK
2P8S or 3P8S LEDs	LPS4018-103ML	10	0.200 max	1.3	4x4x1.8	Coilcraft

Capacitor Selection

Small size X5R or X7R ceramic capacitors with low ESR are recommended for all applications. A 10 μ F input capacitor next to the inductor and an additional small 1 μ F close to the driver VIN pin is required. On the output, a 1 μ F capacitor is ideal. The voltage rating of these capacitors should exceed the maximum possible voltage at the corresponding pins.

Table 2. Recommended Ceramic Capacitor Vendors

Manufacturer	Website
Murata	www.murata.com
AVX	www.avx.com
Taiyo Yuden	www.t-yuden.com

Diode Selection

Using a Schottky diode is recommended because of its low forward voltage drop and fast reverse recovery time. The current rating of the Schottky diode should exceed the peak current of the boost converter. The voltage rating should also exceed the OVP value. Schottky diodes with 40V voltage rating (or higher) are recommended.

Table 3. Recommended Schottky Diodes

Application	Schottky Diode Part Number	Forward Voltage (V)	Forward Current (mA)	Reverse Voltage (V)	Manufacturer
2P8S LEDs	PMEG4005EJ	0.42	500	40	NXP
3P8S LEDs	PMEG4010EJ	0.54	1000	40	NXP

Layout Considerations

PCB layout is very important for high frequency switching regulators in order to keep the loop stable and minimize noise. A small 1 μ F ceramic capacitor C_{VIN} should be placed close to the IC VIN pin to get the best decoupling. The path of the inductor L1, Schottky diode D1 and output capacitor COUT should be kept as short as possible to minimize noise and ringing.

Packaging Information

WLCSP-9 1.2mm x 1.2mm

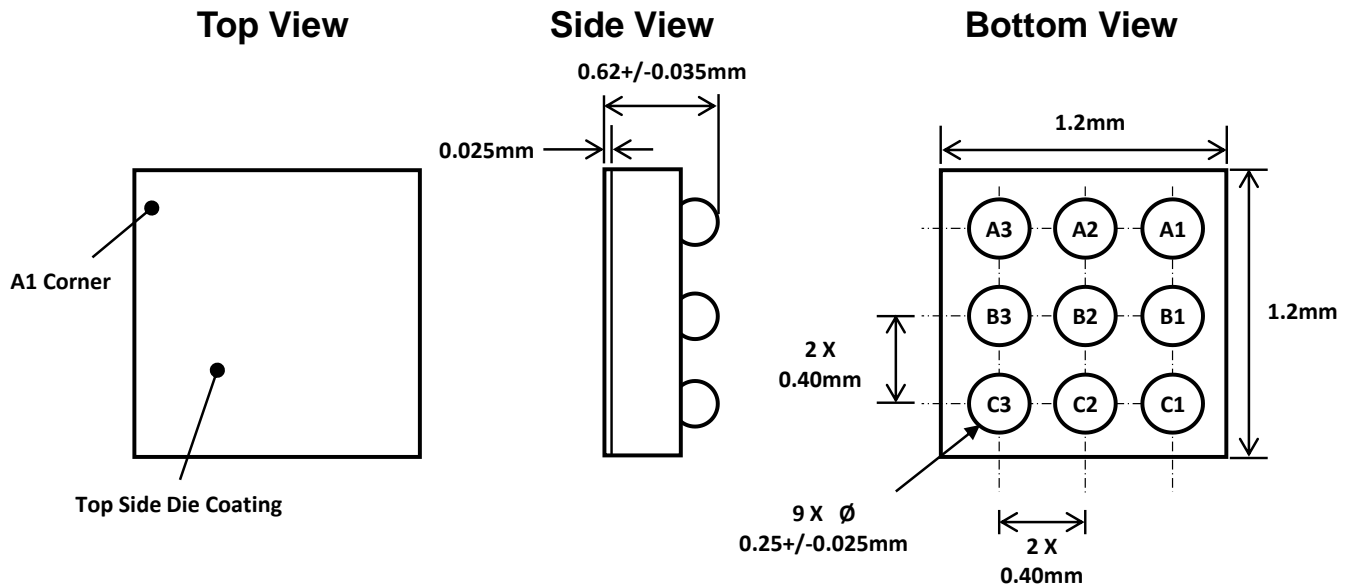

Recommended Footprint

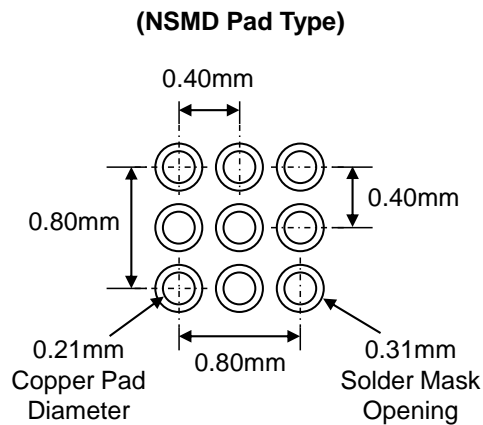

* Dimensions are in millimeters.

Kinetic Technologies cannot assume responsibility for use of any circuitry other than circuitry entirely embodied in a Kinetic Technologies product. No intellectual property or circuit patent licenses are implied. Kinetic Technologies reserves the right to change the circuitry and specifications without notice at any time.