

TOPAZ

SEMICONDUCTOR

VP0535, VP0540

P-CHANNEL ENHANCEMENT-MODE D-MOS FETs

ORDERING INFORMATION

Sorted Chips in Waffle Pack	VP0535ND	VP0540ND
TO-92 Plastic Package	VP0535N3	VP0540N3
Description	-350V, 75Ω	-400V, 75Ω

FEATURES

- Gate Stand-off Voltage, ±40V min.
- Low Output and Transfer Capacitances
- N-Channel Complements Available
- High Drain-Source Breakdown

APPLICATIONS

- Motor Controls
- Logic Interfaces
- Pulse Amplifiers
- Level Translators

ABSOLUTE MAXIMUM RATINGS (T_c = +25°C unless otherwise noted)

Drain-Source Voltage		
VP0535	-350V	
VP0540	-400V	
Drain-Gate Voltage (R _{GS} = 1MΩ)		
VP0535	-350V	
VP0540	-400V	
Gate-Source Voltage	±40V	
Continuous Drain Current	T _c = +100°C	T _c = -25°C
TO-92 Pkg.	-0.05A	-0.14A
Peak Pulsed Drain Current	-0.2A	

Maximum Power Dissipation		
	T _c = +100°C	T _c = +25°C
TO-92 Pkg.	0.4W	3.0W
Linear Derating Factor		
	Junction to Ambient	Junction to Case
	(mW/°C)	(mW/°C)
TO-92 Pkg.	3.0	24
Operating Junction and Storage Temperature Range	-55 to +150°C	
Lead Temperature (1/16" from mounting surface for 10 Sec)	+300°C	

PIN CONFIGURATION

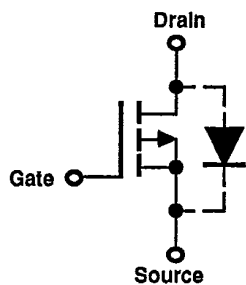

TO-226A (TO-92)

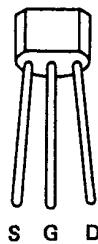

See Package 5

CHIP CONFIGURATION

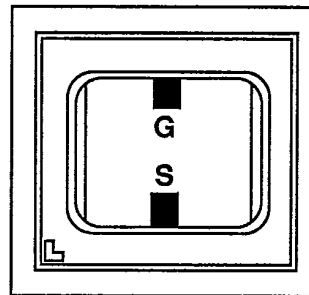

Dimensions: 0.054 x 0.051 x 0.020 inches
Drain is backside contact



ELECTRICAL CHARACTERISTICS ($T_C = +25^\circ\text{C}$ unless otherwise noted)

#	CHARACTERISTICS	VP0535			VP0540			UNIT	TEST CONDITIONS
		MIN	TYP	MAX	MIN	TYP	MAX		
1	BV_{DSS} Drain-Source Breakdown Voltage	-350			-400			V	$I_D = -1.0\text{mA}, V_{GS} = 0$
2	$V_{GS(th)}$ Gate-Source Threshold Voltage	-2.0		-4.5	-2.0		-4.5	V	$V_{DS} = V_{GS}$ $I_D = -1.0\text{mA}$
3	I_{GSS} Gate-Body Leakage Current			-100			-100	nA	$V_{DS} = -30\text{V}, V_{GS} = 0$
4	I_{DSS} Drain-Source OFF Leakage Current		-0.1	-10				μA	$V_{DS} = +30\text{V}, V_{GS} = 0$
5	I_{DSS} Drain-Source OFF Leakage Current		-0.03	-500				μA	$V_{DS} = -350\text{V}$ $V_{GS} = 0$
6									$V_{DS} = -280\text{V}$ $V_{GS} = 0$ $T_C = +125^\circ\text{C}$
7						-0.1	-10		$V_{DS} = -400\text{V}$ $V_{GS} = 0$
8						-0.03	-500		$V_{DS} = -320\text{V}$ $V_{GS} = 0$ $T_C = +125^\circ\text{C}$
9	$I_{D(on)}$ ON Drain Current(1)	-25	-120		-25	-120		mA	$V_{DS} = -25\text{V}$ $V_{GS} = -5\text{V}$
10		-200	-400		-200	-400			$V_{GS} = -10\text{V}$
11	$r_{DS(on)}$ Drain-Source(1) ON Resistance		55	100		55	100	ohms	$V_{GS} = -5\text{V}$ $I_D = -10\text{mA}$ $T_C = +125^\circ\text{C}$
12			78	170		78	170		$V_{GS} = -10\text{V}$
13			48	75		48	75		$I_D = -50\text{mA}$ $T_C = +125^\circ\text{C}$
14			73	125		73	125		
15	g_{fs} Common-Source(1) Forward Transcond.	50	110		50	100		mS	$V_{DS} = -25\text{V}, I_D = -50\text{mA}$ $f = 1\text{KHz}$
16	C_{iss} Common-Source Input Capacitance			60			60	pF	$V_{DS} = -25\text{V}, V_{GS} = 0$ $f = 1\text{MHz}$
17	C_{rss} Common-Source Reverse Transfer Capacitance			5.0			5.0		
18	C_{oss} Common-Source Output Capacitance			20			20		
19	$t_{d(on)}$ Turn-ON Delay Time			10			10	nsec	$V_{DD} = -25\text{V}$ $R_L = 100\Omega$ $R_G = 51\Omega$ $V_{GS(on)} = -10\text{V}$
20	t_r Rise Time			15			15		
21	$t_{d(off)}$ Turn-OFF Delay Time			15			15		
22	t_f Fall Time			10			10		
23	I_b Continuous Source Current	-0.05			-0.05			A	
24	I_{SM} Peak Source Current(1)			-0.2			-0.2		
25	V_{DS} Source-Drain(1) Forward Voltage		1.2			1.2		V	$V_{GS} = 0, I = .14\text{A}$

Note 1: Pulse Test 80 μ Sec, 1% Duty Cycle

TOPAZ
SEMICONDUCTOR

VP0535, VP0540

SWITCHING TIMES TEST CIRCUIT

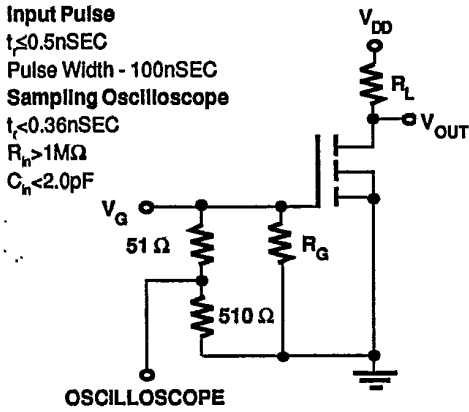

TEST WAVEFORMS

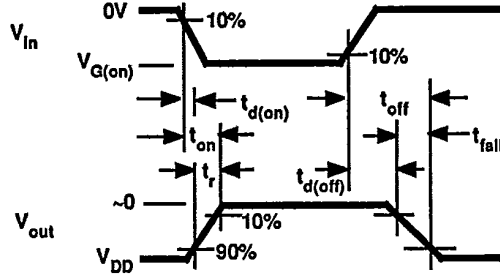

TYPICAL PERFORMANCE CHARACTERISTICS ($T_c = +25^\circ C$ unless otherwise noted)

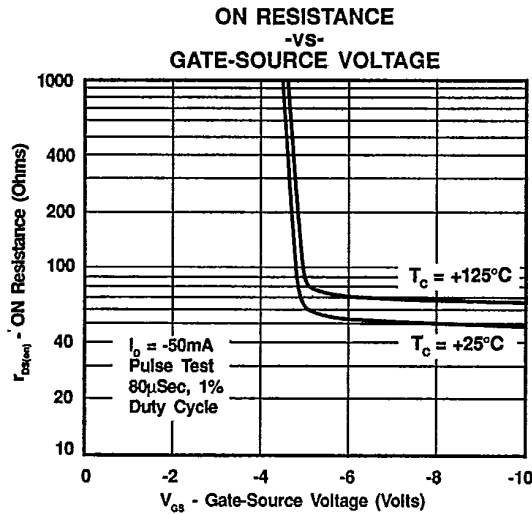
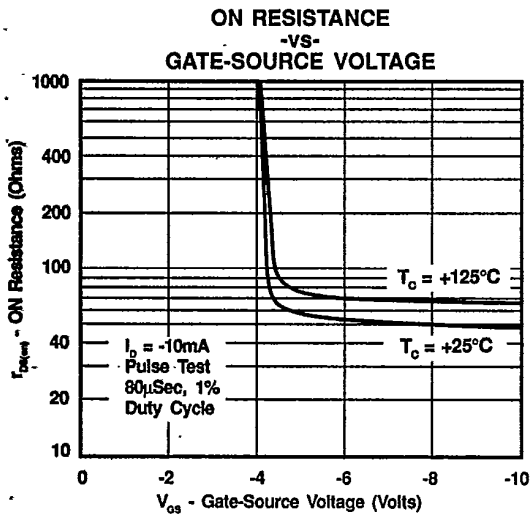

TYPICAL PERFORMANCE CHARACTERISTICS ($T_c = +25^\circ\text{C}$ unless otherwise noted)

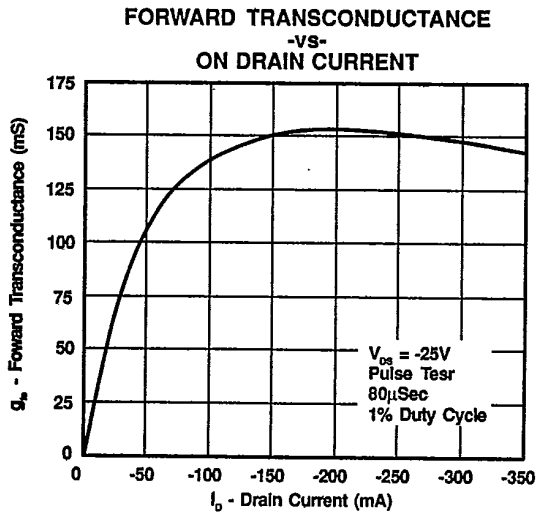
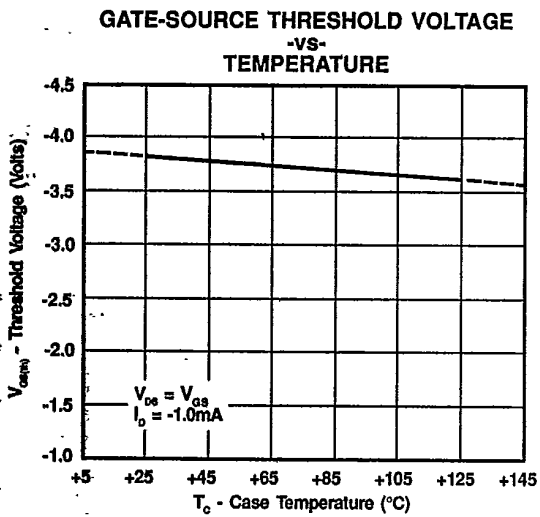
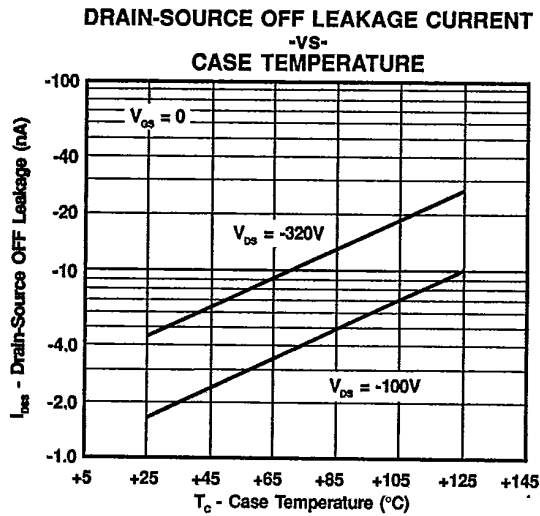
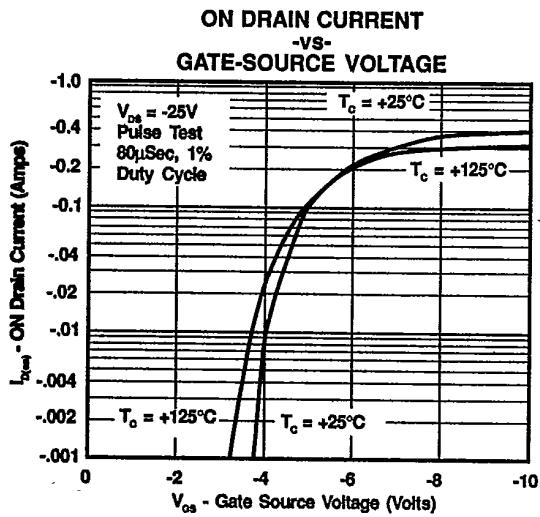

This datasheet has been downloaded from:

www.DatasheetCatalog.com

Datasheets for electronic components.