

ESD9N5BM

**1-Line, Bi-directional, Ultra-low Capacitance,
Transient Voltage Suppressors**

<http://www.omnivision-group.com>

Descriptions

The ESD9N5BM is a transient voltage suppressors (TVS) which provide a very high level protection for sensitive electronic components that may be subjected to electrostatic discharge (ESD). It is designed to replace multiplayer varistors (MLV) in consumer equipments applications such as mobile phone, notebook, PAD, STB, LCD TV etc.

The ESD9N5BM was past ESD transient voltage up to $\pm 8\text{kV}$ (contact) according to IEC61000-4-2 and withstand peak current up to 2.5A for 8/20 μs pulse according to IEC61000-4-5.

The ESD9N5BM is available in DFN1006 package. Standard products are Pb-free and Halogen-free.



DFN1006-2L (Bottom View)

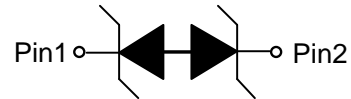

Circuit Diagram

Features

- Reverse stand-off voltage: $\pm 5.0\text{V}$ max.
- Transient protection for each line according to
 - IEC61000-4-2 (ESD) : $\pm 8\text{kV}$ (contact discharge)
 - : $\pm 15\text{kV}$ (air discharge)
 - IEC61000-4-4 (EFT) : 40A (5/50ns)
 - IEC61000-4-5 (surge) : 2.5A (8/20 μs)
- Ultra-low capacitance
- Low clamping voltage
- Low leakage current
- Small package



* = Month (A-Z)

'U = Device code

Marking (Top View)

Applications

- Mobile phone
- PAD
- Notebook
- STB
- LCD TV
- Digital camera
- Other electronic equipment

Order information

Device	Package	Shipping
ESD9N5BM-2/TR	DFN1006-2L	10000/Tape&Reel

Absolute maximum ratings

Parameter	Symbol	Rating	Unit
Peak pulse power (tp=8/20μs)	Ppk	40	W
Peak pulse current (tp=8/20μs)	Ipp	2.5	A
ESD voltage IEC61000-4-2 air	V _{ESD}	±15	KV
ESD voltage IEC61000-4-2 contact		±8	
Junction temperature	T _J	125	°C
Operating temperature	T _{OP}	-40~85	°C
Lead temperature	T _L	260	°C
Storage temperature	T _{STG}	-55~150	°C

Electronics characteristics (Ta=25 °C, unless otherwise noted)

Parameter	Symbol	Condition	Min.	Typ.	Max.	Unit
Reverse stand-off voltage	V _{RWM}				±5.0	V
Reverse leakage current	I _R	V _{RWM} = 5V			1.0	μA
Reverse breakdown voltage	V _{BR}	I _T = 1mA	7.0	8.5	10.0	V
Clamping voltage ¹⁾	V _{CL}	V _{ESD} = 8kV		26		V
Clamping voltage ²⁾	V _C	I _{pp} =1A tp=8/20μs			13	V
		I _{pp} =2.5A tp=8/20μs			16	V
Junction capacitance	C _J	F=1MHz, V _R =0V		1.0	1.5	pF

Notes:

- 1) Contact discharge mode, according to IEC61000-4-2.
- 2) Non-repetitive current pulse, according to IEC61000-4-5.

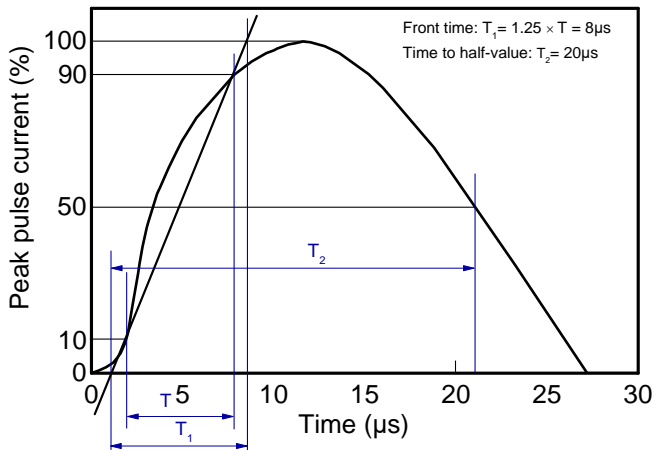
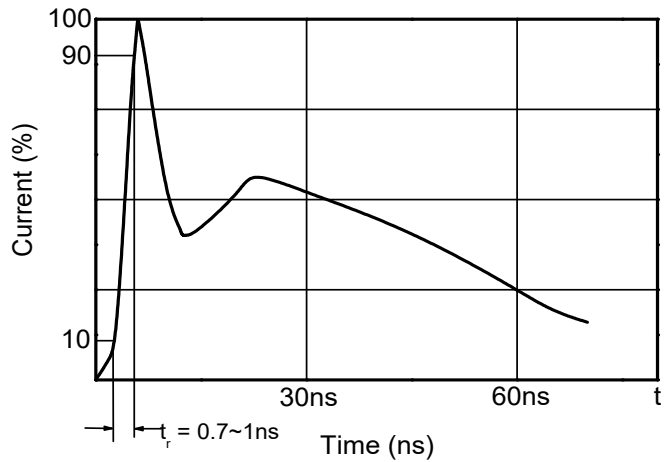
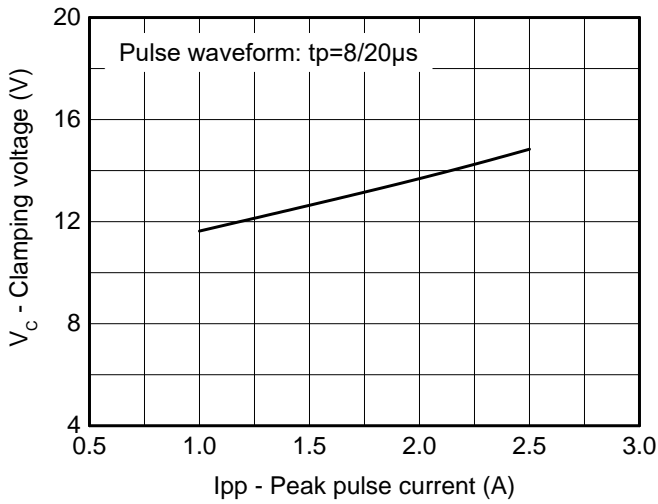
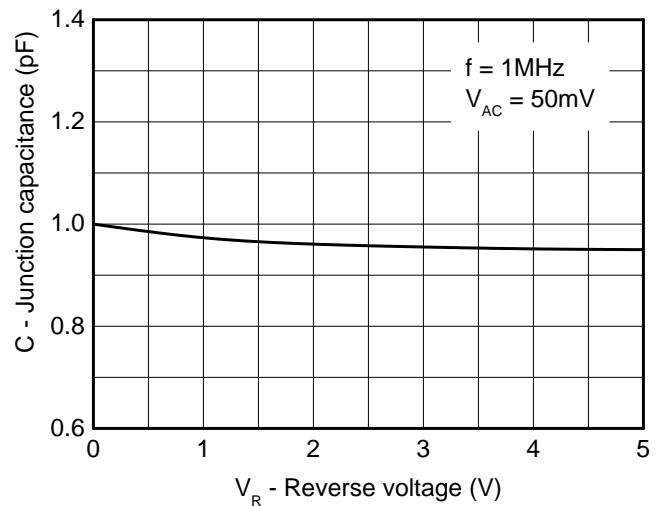
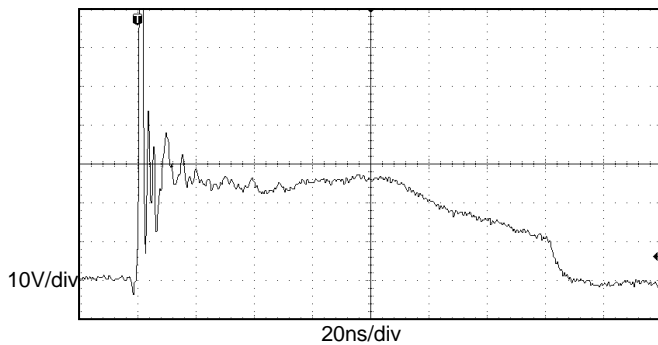
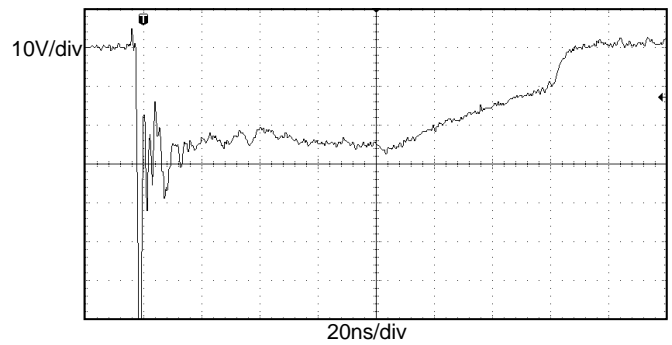
Typical characteristics (Ta=25°C, unless otherwise noted)

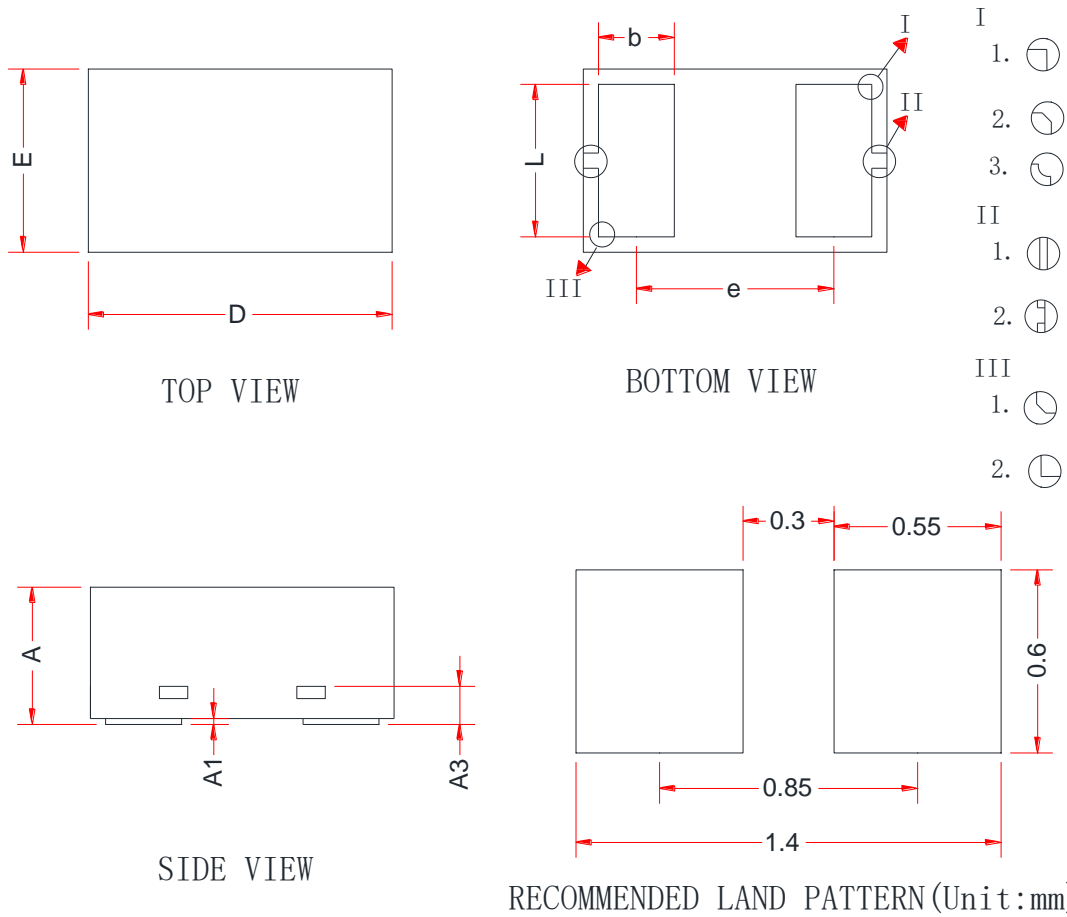
8/20μs waveform per IEC61000-4-5

Contact discharge current waveform per IEC61000-4-2

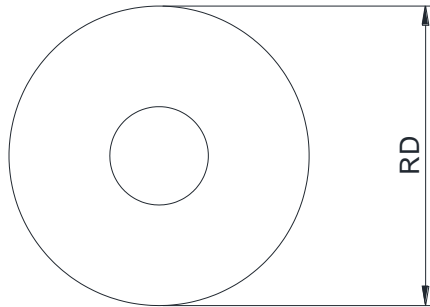
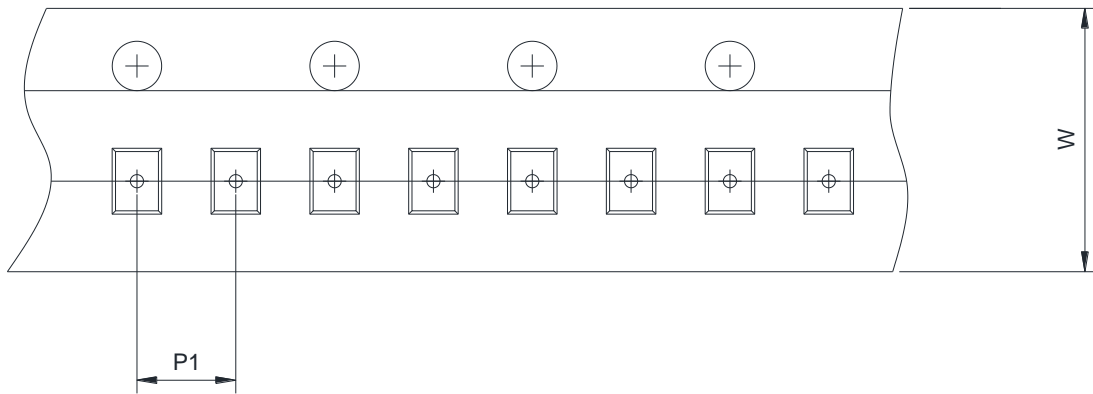
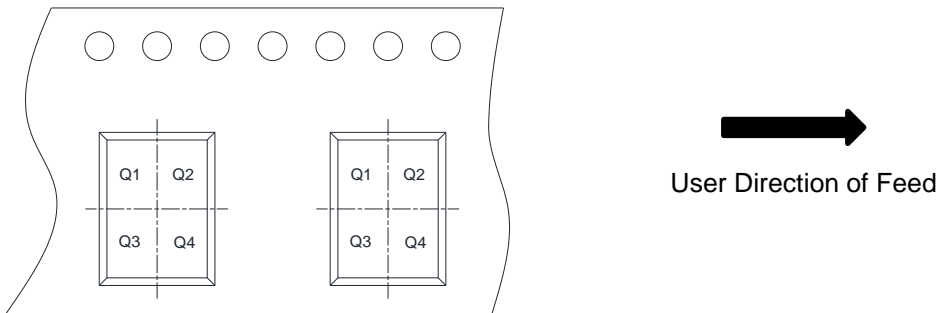
Clamping voltage vs. Peak pulse current

Capacitance vs. Reverse voltage

**ESD clamping
(+8kV contact discharge per IEC61000-4-2)**

**ESD clamping
(-8kV contact discharge per IEC61000-4-2)**

PACKAGE OUTLINE DIMENSIONS
DFN1006-2L

Symbol	Dimensions in Millimeters		
	Min.	Typ.	Max.
A	0.36	0.45	0.50
A1	0.00	0.02	0.05
A3	0.125 Ref.		
D	0.95	1.00	1.05
E	0.55	0.60	0.65
b	0.20	0.25	0.30
L	0.45	0.50	0.55
e	0.65 BSC		

TAPE AND REEL INFORMATION
Reel Dimensions

Tape Dimensions

Quadrant Assignments For PIN1 Orientation In Tape

RD	Reel Dimension	<input checked="" type="checkbox"/> 7inch	<input type="checkbox"/> 13inch
W	Overall width of the carrier tape	<input checked="" type="checkbox"/> 8mm	<input type="checkbox"/> 12mm <input type="checkbox"/> 16mm
P1	Pitch between successive cavity centers	<input checked="" type="checkbox"/> 2mm	<input type="checkbox"/> 4mm <input type="checkbox"/> 8mm
Pin1	Pin1 Quadrant	<input checked="" type="checkbox"/> Q1	<input checked="" type="checkbox"/> Q2 <input type="checkbox"/> Q3 <input type="checkbox"/> Q4