

## 0.8A Standalone Linear Li-Ion Battery Charger with Thermal Regulation

### General Description

The FC9054 is a complete constant-current/constant-voltage linear charger for single cell lithium-ion batteries. Its SOT-23-5 package and low external component count make the FC9054 ideally suited for portable applications. Furthermore, the FC9054 can work within USB and wall adapter. No blocking diode is required due to the internal PMOSFET architecture and have prevent to negative Charge Current Circuit. Thermal feedback regulates the charge current to limit the die temperature during high power operation or high ambient temperature. The charge voltage is fixed at 4.2V, and the charge current can be programmed externally with a single resistor. The FC9054 automatically terminates the charge cycle when the charge current drops to 1/10th the programmed value after the final float voltage is reached.

FC9054 Other features include current monitor, under voltage lockout, automatic recharge and charge status pin to indicate charge termination.

### Features

- Programmable Charge Current Up to 800mA
- No MOSFET, Sense Resistor or Blocking Diode Rquired
- Complete Linear Charger in SOT-23-5 Package for Single Cell Lithium-Ion Batteries
- Constant-Current/Constant-Voltage
- Charges Single Cell Li-Ion Batteries Directly from USB Port
- Preset 4.2V Charge Voltage with 1.5% Accuracy
- Automatic Recharge
- Charge Status Output Pins
- C/10 Charge Termination
- 2.9V Trickle Charge Threshold
- Soft-Start Limits Inrush Current
- Available Radiator in SOT23-5 Package, the Radiator need connect GND or impending

### Applications

- Cellular Telephones, PDAs, GPS
- Charging Docks and Cradles
- Digital Still Cameras, Portable Devices
- USB Bus-Powered Chargers, Chargers

### Package Types

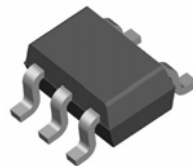

Figure 1. Package Types of FC9054

## Pin Configurations

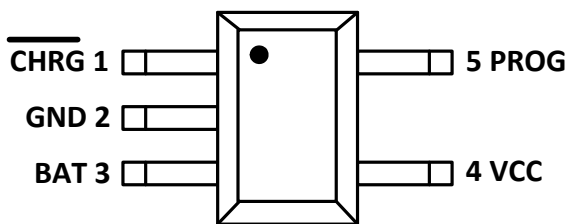
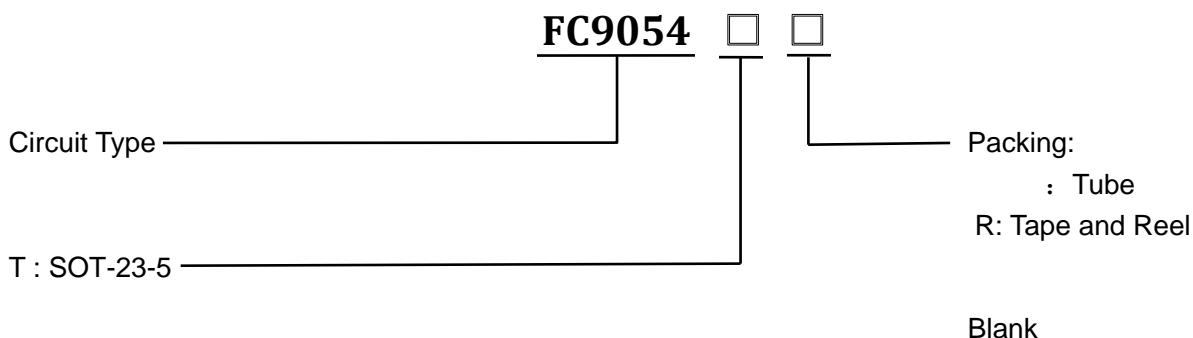

Figure 2 Pin Configuration of FC9054(Top View)

## Pin Description

Pin Name	Pin Number	
$\overline{\text{CHRG}}$	1	When the battery is being charged, the $\overline{\text{CHRG}}$ pin is pulled low by an internal switch, otherwise $\overline{\text{CHRG}}$ pin is in high impedance state.
GND	2	GND
BAT	3	Connect the positive terminal of the battery to BAT pin. BAT pin draws less than 2uA current in chip disable mode or in sleep mode. BAT pin provides charge current to the battery and provides regulation voltage of 4.2V.
Vcc	4	VIN is the power supply to the internal circuit. When VIN drops to within 30mv of the BAT pin voltage, FC9054 enters low power sleep mode, dropping BAT pin's current to less than 2uA
PROG	5	charge current is set by connecting a resistor $R_{\text{PROG}}$ from this pin to GND. When in precharge mode, the PROG pin's voltage is regulated to 0.1V. When in constant charge current mode, the PROG pin's voltage is regulated to 1V. In all modes during charging, the voltage on PROG pin can be used to measure the charge current as follows: $I_{\text{BAT}} = (V_{\text{PROG}} / R_{\text{PROG}}) * 1000$ ----(FC9054)

## Ordering Information





# FC9054

## Function Block Diagram

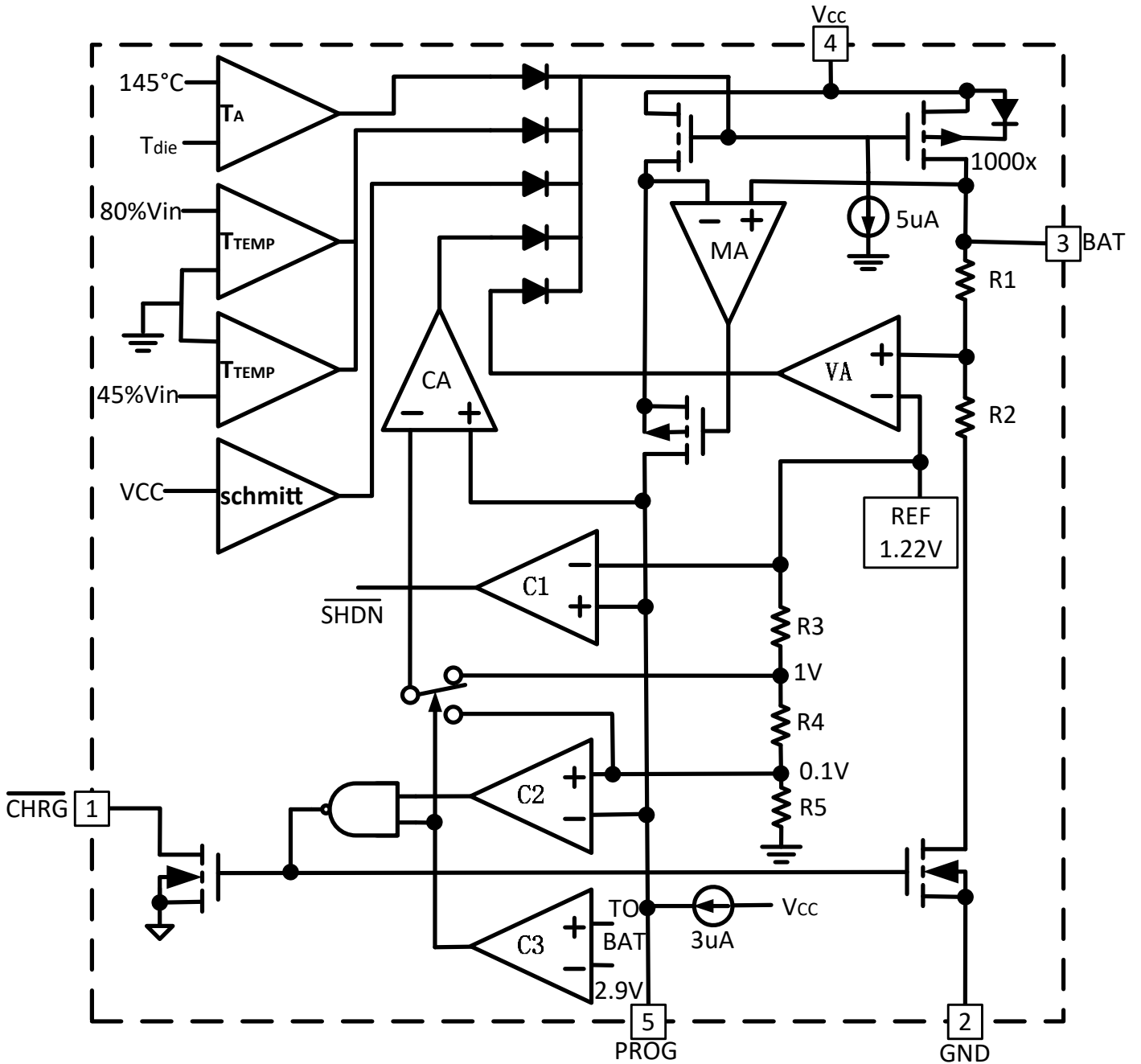



# FC9054

## Electrical Characteristics

(VIN = 5V, TA = 25°C unless otherwise specified)

Parameters	Symbol	Test Condition	Min.	Typ.	Max.	Unit
Input Supply Voltage	VCC		4.0	5	8.0	V
Input Supply Current	ICC	Charge Mode, R <sub>PROG</sub> = 2k Shutdown Mode (R <sub>PROG</sub> Not Connected, V <sub>CC</sub> < V <sub>BAT</sub> , or V <sub>CC</sub> < V <sub>UV</sub> )		150 55	500 100	μA
Regulated Output (Float) Voltage	VFLOAL	0°C ≤ TA ≤ 85°C, IBAT = 40mA	4.137	4.2	4.26	V
BAT Pin Current	IBAT	R <sub>PROG</sub> = 2k, Current Mode R <sub>PROG</sub> = 3k, Current Mode Standby Mode, V <sub>BAT</sub> = 4.2V	450 300 0	500 350 -2.5	550 400 -2.6	mA mA uA
Trickle Charge Current	ITRIKL	V <sub>BAT</sub> < V <sub>TRIKL</sub> , R <sub>PROG</sub> = 2K	60	65	70	mA
Trickle Charge Threshold Voltage	VTRIKL	R <sub>PROG</sub> = 2K, V <sub>BAT</sub> Rising	2.8	2.9	3.0	V
Trickle Charge Hysteresis Voltage	VTRHYS	R <sub>PROG</sub> = 2K	60	80	100	mv
Undervoltage	Vuv	V <sub>CC</sub> increasing	3.5	3.7	3.9	V
PROG pin voltage	Vprog	R <sub>PROG</sub> = 2k, Current Mode	0.9	1	1.1	V
CHRG pin voltage	V <sub>CHRG</sub>	I <sub>CHRG</sub> = 5mA		0.3	0.6	V
Junction Temperature in Constant Temperature Mode	T <sub>L M</sub>			145		°C

## Typical Application Circuit

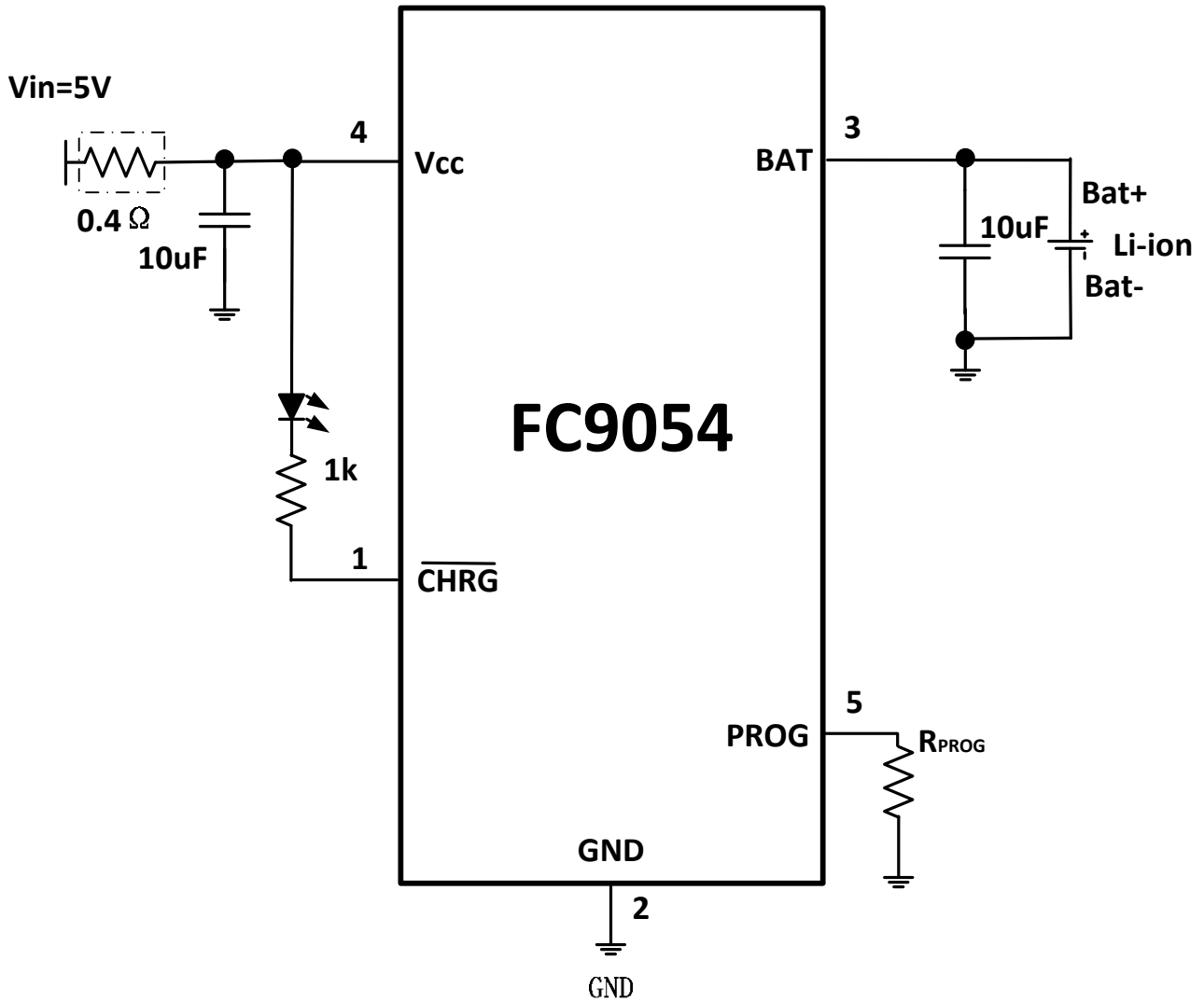

## Function Description

### Precharge Current

The FC9054 is a linear charger circuit specially designed for single cell lithium-ion batteries. When the FC9054 is powered with a battery connected, the IC first detects if the cell voltage is ready for full charge current. If the cell voltage is less than the prequal level (3V typ), the battery is precharged with a 55mA current until the cell reaches the proper level. The full charging current, as set by PROG pin, is then applied

### Soft-Start

The FC9054 includes a soft-start function to control the rise rate of the charging current rising from zero to the fast-charging current level in constant current mode. During charger soft-start, the FC9054 ramps up the voltage on PROG pin with constant well-controlled slew rate. The charging current is proportional to the PROG voltage. The soft-start time is 20us (typical), which is independent of the fast-charging current level.

### Charging Current Setting

The charge current is programmed by using a resistor from the PROG pin to the ground. The battery charge current is 1000 times the current out of the PROG pin. The battery charge current is calculated by the following equation:

$$I_{CHG} = V_{PROG} * 1000 / R_{PROG}$$

Where  $V_{PROG}$  is PROG regulation voltage (nominal=1V). The charging current set factor and the PROG regulation voltage are shown in the Electrical Characteristics. The PROG regulation voltage is reduced by thermal regulation function.

### Battery Full Indication

Current mode charging stopped when  $I_{bat}$  falls to 10% of the current set by  $R_{PROG}$  and the charger is in voltage mode. After the FC9054 stopped current mode charging, it keeps operating in voltage mode without turning off the charger. When the PROG pin's voltage down to 100mv over 2ms, the charger will stop operating and the  $V_{cc}$  current down to 55uA.

### Charge Status Outputs

The open-drain CHRG outputs can be used to drive LED indicate four charger operations are shown in Table 1.

Charge state	Red LED (CHRG)
charging	bright
Charge Termination	extinguish
$V_{in}$ too low; Temperature of battery too low or too high; no battery	extinguish
BAT PIN Connect 10u Capacitance; No battery	Extinguish (T=1-4s)

Table 1.

### Increase the heat regulating current

Reduce the voltage drop across the internal MOSFET can significantly reduce the power consumption of the IC. During thermal regulation, this has an increased current supplied to the battery. One strategy is accomplished by an external element (e.g., a resistor or a diode) will be part of the power consumption.

Example: FC9054 is powered by a 5V AC adapter, it charge to one with a 3.75V voltage lithium-ion battery, and set the full-scale charge current 800mA by programming. Assuming  $\theta_{JA}$  is 125 °C/W, at 25 °C ambient temperature conditions, the charging current is approximately:

$$I_{BAT} = \frac{120^{\circ}\text{C} - 25^{\circ}\text{C}}{(5\text{V} - 3.75\text{V}) \cdot 125^{\circ}\text{C}/\text{W}} = 608\text{mA}$$

Increase the voltage across the resistor in series with a 5V AC adapter(Figure 3), the on-chip power dissipation can be reduced, thereby increasing the heat regulating current:

$$I_{BAT} = \frac{120^{\circ}\text{C} - 25^{\circ}\text{C}}{(V_S - I_{BAT} R_{CC} - V_{BAT}) \cdot \theta_{JA}}$$

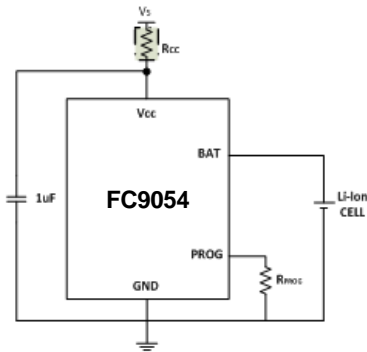

Figure 3: One kind of maximizing charge current thermal regulation circuit mode

Use the quadratic equation can be obtained  $I_{BAT}$

$$I_{BAT} = \frac{(V_S - V_{BAT}) - \sqrt{(V_S - V_{BAT})^2 - \frac{4R_{CC}(120^\circ\text{C} - T_A)}{\theta_{JA}}}}{2R_{CC}}$$

Take  $R_{CC}=0.25\Omega$ ,  $V_S=5V$ ,  $V_{BAT}=3.75V$ ,  $T_A=25^\circ\text{C}$ , and  $\theta_{JA}=125^\circ\text{C/W}$ , we can calculate the heat adjustment charge current:  $I_{BAT} = 708\text{mA}$ . The results shows that the structure can be full scale output 800mA charging current at higher ambient temperatures.

Although this application can deliver more energy to the battery in heat regulating mode and shorten the charging time, But in voltage mode, if VCC becomes low enough leaving FC9054 state at low voltage drop, It is actually possible to extend the charging time. Figure 4 shows how the circuit becomes large as the  $R_{cc}$  resulting voltage drop.

When in order to maintain a smaller component size and to avoid voltage drop leaving the  $R_{cc}$  values minimized, this technology can play a role in the best. Keep in mind: you should select a sufficient power handling capability resistor.

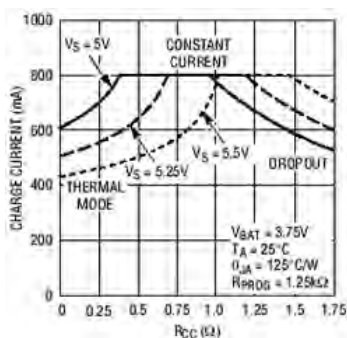
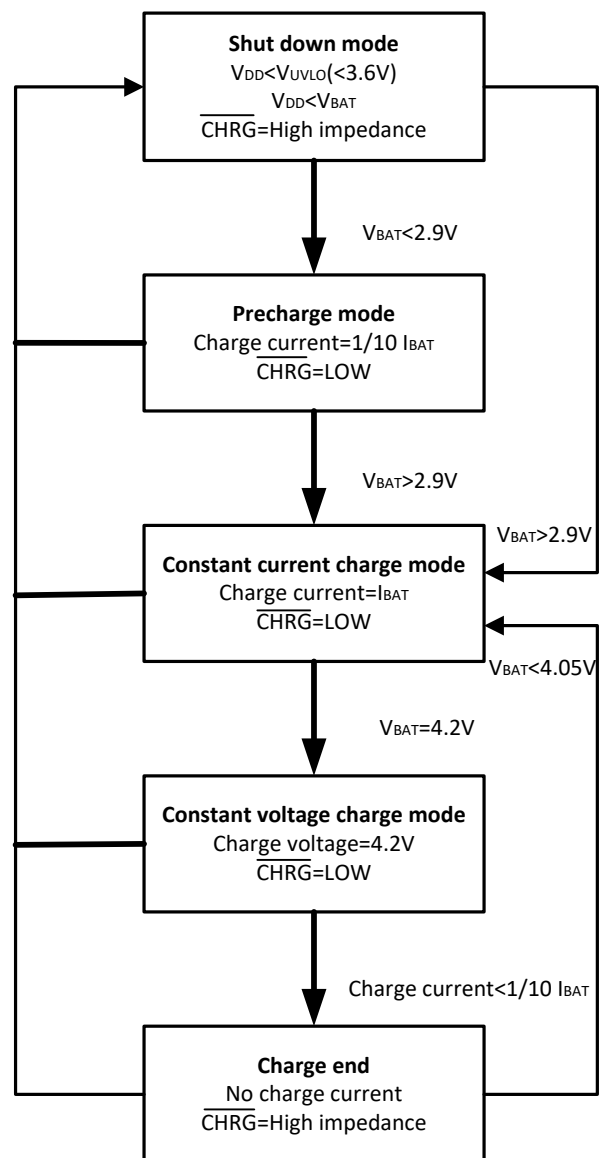

Figure 4: Charging current relationship with the RCC curve

### Automatic restart

Once the charge cycle is terminated, FC9054 immediately adopt a comparator with 1.8ms filter time continuously monitor the BAT pin voltage. When the battery voltage drops below 4.05V or less (Generally corresponding to the battery capacity from 80 to 90%), charging cycle restart. This ensures that the battery is maintained at (or near) a full charge state, and eliminates the periodic need to start charging cycle. A typical charge cycle state diagram is shown below.



## Package Information

### SOT-23-5 Package Outline Dimensions

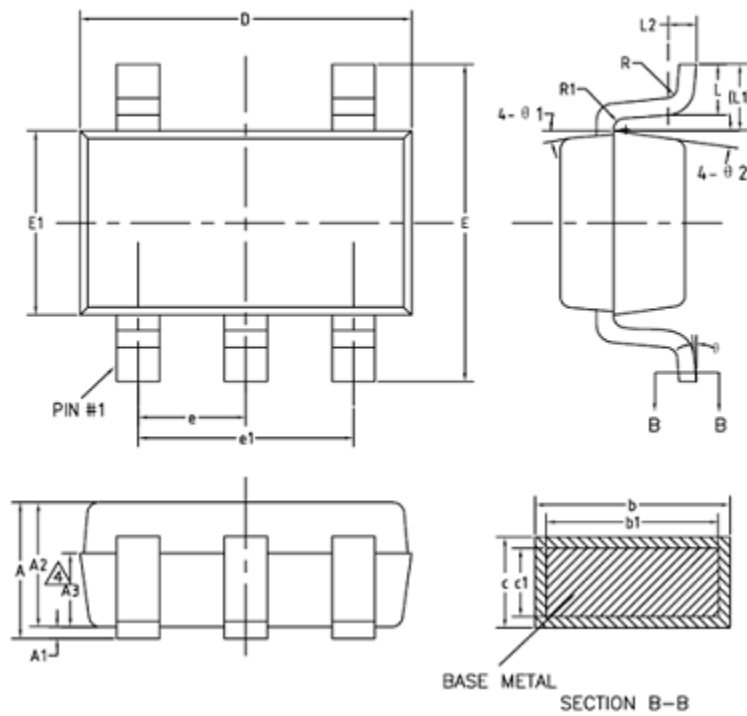

COMMON DIMENSIONS  
(UNITS OF MEASURE=MILLIMETER)

SYMBOL	MIN	NOM	MAX
A	—	—	1.45
A1	0	—	0.15
A2	0.90	1.15	1.30
A3	0.60	0.65	0.70
b	0.39	—	0.49
b1	0.35	0.40	0.45
c	0.08	—	0.22
c1	0.08	0.13	0.20
D	2.80	2.90	3.00
E	2.60	2.80	3.00
E1	1.50	1.60	1.70
e	0.85	0.95	1.05
e1	1.80	1.90	2.00
L	0.35	0.45	0.60
L1	0.60REF		
L2	0.25BSC		
R	0.10	—	—
R1	0.10	—	0.25
θ	0°	—	8°
θ 1	7°	9°	11°
θ 2	8°	10°	12°

NOTES:

ALL DIMENSIONS REFER TO JEDEC STANDARD MO-178 C  
DO NOT INCLUDE MOLD FLASH OR PROTRUSIONS.