

NPN Silicon Epitaxial Planar Transistor

PXT4401

FEATURES

- High current (max.600mA)
- Low voltage (max.40V)
- Complement:PXT4403

HF

APPLICATIONS

- High-speed saturated switching amplification

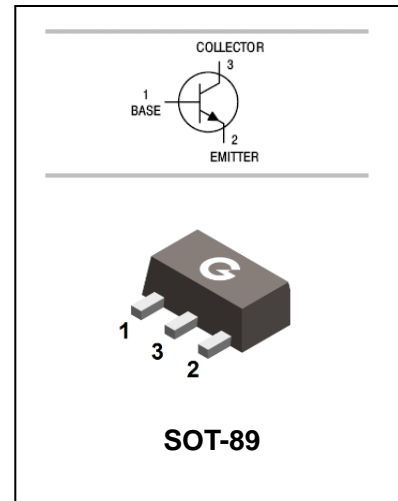

ORDERING INFORMATION

Type No.	Marking	Package Code
PXT4401	2X	SOT-89

MAXIMUM RATING @ Ta=25°C unless otherwise specified

Symbol	Parameter	Value	Units
V _{CB0}	Collector-Base Voltage	60	V
V _{CEO}	Collector-Emitter Voltage	40	V
V _{EBO}	Emitter-Base Voltage	6	V
I _C	Collector Current -Continuous	600	mA
P _C	Collector Power Dissipation	500	mW
R _{θJA}	Thermal Resistance,Junction to Ambient	357	°C/W
T _j ,T _{stg}	Junction and Storage Temperature	-55 to +150	°C

NPN Silicon Epitaxial Planar Transistor
PXT4401
ELECTRICAL CHARACTERISTICS @ Ta=25°C unless otherwise specified

Parameter	Symbol	Test conditions	MIN	TYP	MAX	UNIT
Collector-base breakdown voltage	$V_{(BR)CBO}$	$I_C=100\mu A, I_E=0$	60			V
Collector-emitter breakdown voltage	$V_{(BR)CEO}$	$I_C=1mA, I_B=0$	40			V
Emitter-base breakdown voltage	$V_{(BR)EBO}$	$I_E=100\mu A, I_C=0$	6			V
Collector cut-off current	I_{CEX}	$V_{CE}=35V, V_{BE}=-0.4V$			0.1	μA
Base cut-off current	I_{BL}	$V_{CE}=35V, V_{BE}=0.4V$			0.1	μA
DC current gain	h_{FE}	$V_{CE}=1V, I_C=0.1mA$	20			
		$V_{CE}=1V, I_C=1.0mA$	40			
		$V_{CE}=1V, I_C=10mA$	80			
		$V_{CE}=1V, I_C=150mA$	100		300	
		$V_{CE}=2V, I_C=500mA$	40			
Collector-emitter saturation voltage	$V_{CE(sat)}$	$I_C=150mA, I_B=15mA$ $I_C=500mA, I_B=50mA$			0.4 0.75	V
Base-emitter saturation voltage	$V_{BE(sat)}$	$I_C=150mA, I_B=15mA$ $I_C=500mA, I_B=50mA$	0.75		0.95 1.2	V
Transition frequency	f_T	$V_{CE}=10V, I_C=20mA$ $f=100MHz$	250			MHz
Collector output capacitance	C_{ob}	$V_{CB}=5V, I_E=0, f=1MHz$			6.5	pF

NPN Silicon Epitaxial Planar Transistor

PXT4401

TYPICAL CHARACTERISTICS @ Ta=25°C unless otherwise specified

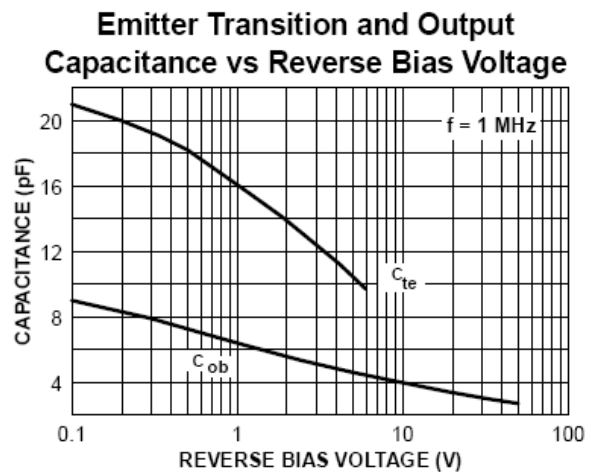
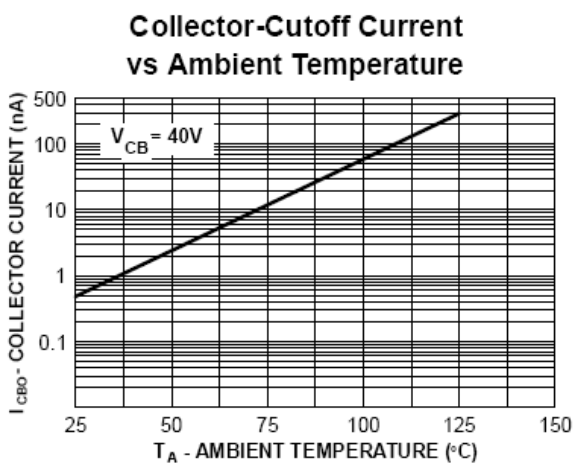
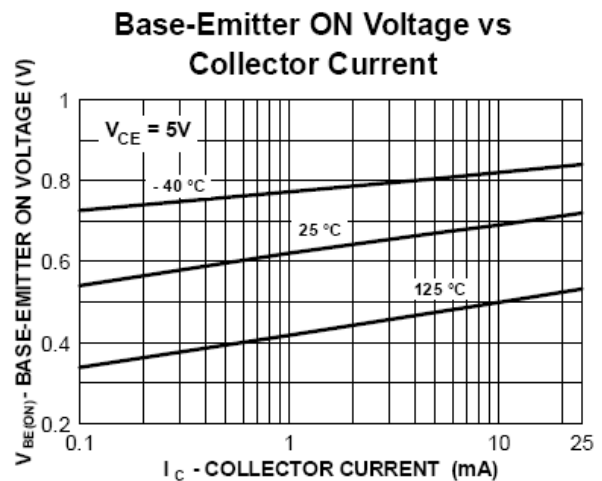
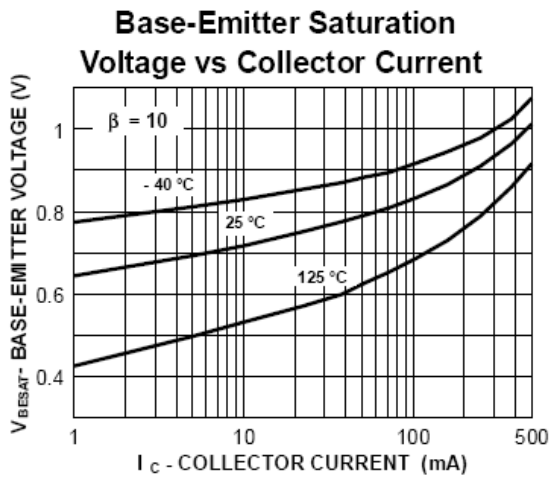
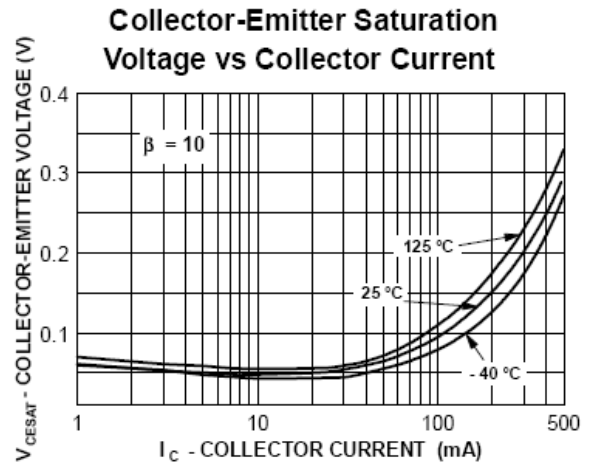
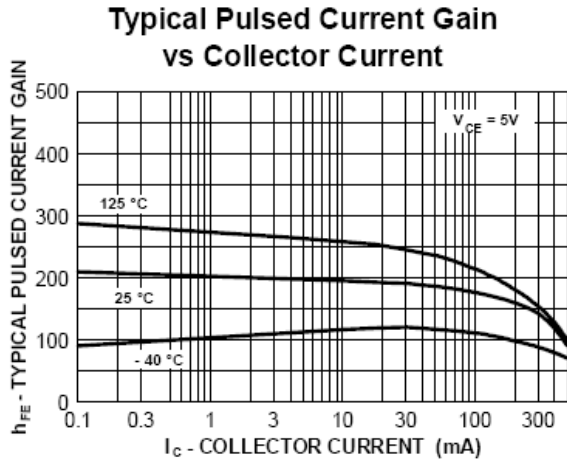

NPN Silicon Epitaxial Planar Transistor

PXT4401

PACKAGE OUTLINE

Plastic surface mounted package

SOT-89

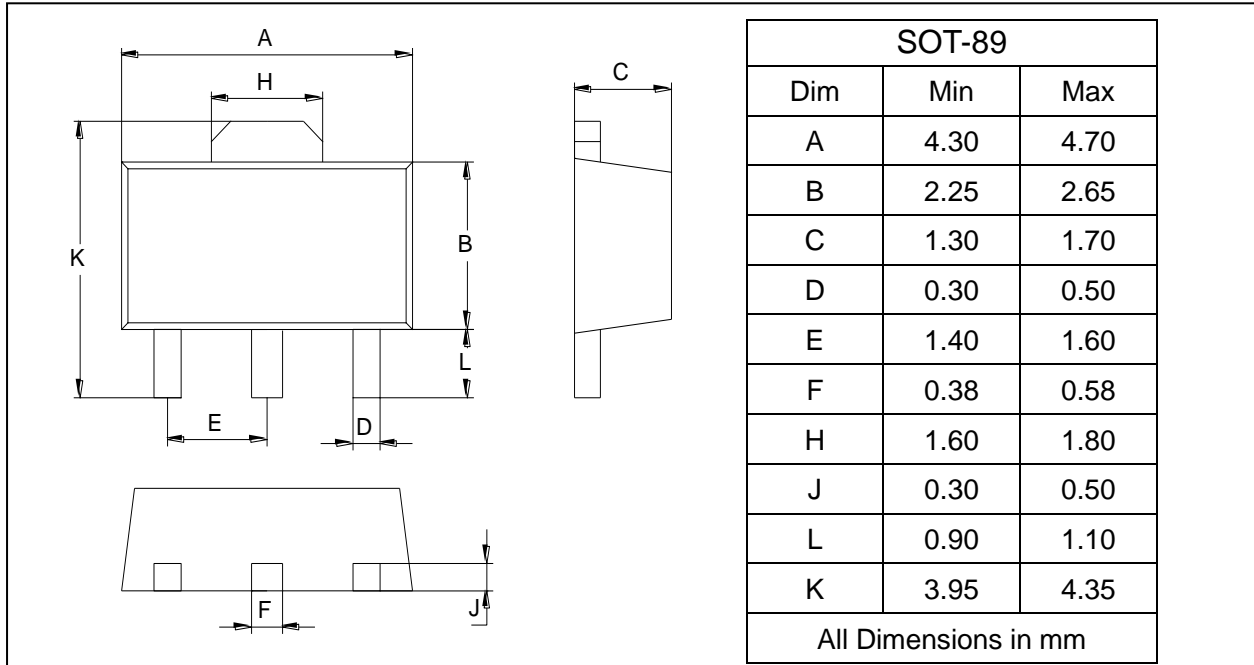

SOLDERING FOOTPRINT

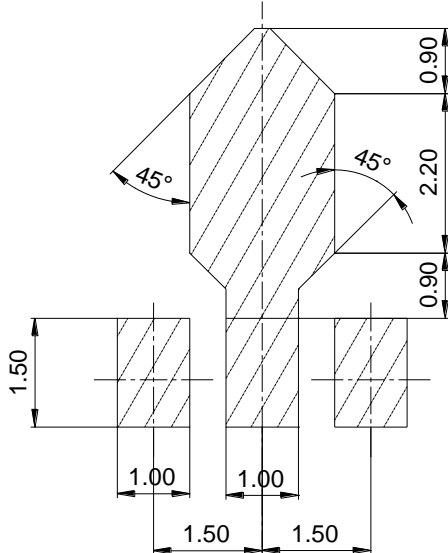

Unit: mm

PACKAGE INFORMATION

Device	Package	Shipping
PXT4401	SOT-89	3000 pcs / Tape & Reel