

53258

**RADIATION TOLERANT
120VDC – 5A
POWER MOSFET OPTOCOUPLER**

Mii

**MICROCIRCUITS PRODUCTS
DIVISION**

Features:

- Design for 100 krad(Si) Total Dose
- Hermetically Sealed in Surface Mount Package
- Low On-resistance
- 5A Continuous Output Current
- Operation over Full Military Temperature Range -55°C to +125°C
- Optically Coupled
- Input / Output Isolation Tested to 1000 VDC
- Shock and Vibration Resistance

Applications:

- Satellite/Space Systems
- Military/High Reliability Systems
- Power Distribution/Switching
- Solenoid Driver
- Stepper Motor Driver
- Switching Heaters

DESCRIPTION

The 53258 is a radiation tolerant Power MOSFET Optocoupler designed for military and space applications. This light-weight device is resistant to damage from severe shock and vibration, and is immune to contact related problems inherent in electro-mechanical relays. The device is enclosed in a hermetic metal package to ensure reliability in harsh environments. Effective isolation of 1000 VDC between control and load circuits is achieved through the use of optical coupling.

Functionally, the device operates as a single-pole single-throw, normally open (1 Form A) DC solid-state relay. The 53258 SSR is actuated by an input current of 5 to 15 mA, which can be supplied from a standard TTL device. Output is provided by a power MOSFET exhibiting very low $R_{DS(ON)}$ and capable of carrying a continuous current of 5 amperes. This device is designed to function with minimal degradation after exposure to 100 krad(Si) total dose. The 53258 SSR is available in a variety of quality levels from COTS to class K including any custom screening requirements. The basic data sheet part is environmentally screened to H level in accordance with Table C-IX of MIL-PRF-38534.

ABSOLUTE MAXIMUM RATINGS

Output Voltage	150 VDC
Continuous Output current.....	5 A
Storage Temperature Range	-65°C to +150°C
Operating Junction Temperature.....	+150°C
Lead Solder Temperature, for 10 seconds	300°C
Continuous Input Current	20 mA
Peak Input Current ⁽¹⁾	100 mA
Reverse Input Voltage.....	6 VDC
Thermal Impedance Junction to Case (Input Diode).....	311°C/W
Thermal Impedance Junction to Case (output Transistor).....	0.329°C/W
WEIGHT:	3.7 grams (typical)

RADIATION TOLERANT

This device contains radiation hardened components and/or other features that provide a level of radiation tolerance. Micropac does not guarantee any level of radiation hardness. Specific lot testing is required to determine the level of radiation hardness. Micropac does not offer this device as compliant to Appendix G (RHA Requirements) of MIL-PRF-38534.

Micropac Industries cannot assume any responsibility for any circuits shown or represent that they are free from patent infringement. Micropac reserves the right to make changes at any time in order to improve design and to supply the best product possible.

RECOMMENDED OPERATING CONDITIONS:

Parameter	Symbol	Min.	Max.	Units
Output Voltage ⁽⁵⁾	$V_{O(OFF)}$		120	VDC
Continuous Output Current	$I_{O(ON)}$		5	A
Input Current (on)	$I_{F(ON)}$	5	15	mA
Input Voltage (off)	$V_{F(OFF)}$	0	1	VDC
Operating Case Temperature	T_C	-55	125	°C

ELECTRICAL SPECIFICATIONS (Pre-Irradiation) $T_C = -55^{\circ}\text{C}$ to $+125^{\circ}\text{C}$ unless otherwise specified

Parameter	Symbol	Min.	Typ.*	Max.	Units	Test Conditions	Notes
Output On-Resistance	$R_{(ON)}$	—	.110	.220	Ω	$I_F = 15\text{ mA}$ $I_O = 2\text{ A}$ Pulse width = 10 ms Duty cycle $\leq 10\%$	
Output Leakage Current	$I_{O(OFF)}$	—	—	250	μA	$V_F = 1\text{ VDC}$ $V_O = 150\text{ VDC}$	
Input Forward Voltage	V_F	—	—	4.20	VDC	$I_F = 15\text{ mA}$	
Input Reverse Breakdown Voltage	V_R	6	40	—	VDC	$I_R = 10\ \mu\text{A}$	
Input-Output Leakage Current	I_{I-O}	—	—	1	μA	$RH \leq 45\%$, $t = 5\text{ s}$ $V_{I-O} = 1000\text{ VDC}$ $T_C = 25^{\circ}\text{C}$	2, 3
Turn-On Time	t_{ON}	—	—	8	ms	$I_F = 15\text{ mA}$ $I_O = 2\text{ A}$ Pulse width = 10 ms Duty cycle $\leq 10\%$	Figure 3
Turn-Off time	t_{OFF}	—	—	2	ms		Figure 3
Rise Time	t_R	—	—	6	ms		4, Figure 3
Fall Time	t_F	—	—	1	ms		

* All typical values are at $T_C = 25^{\circ}\text{C}$ **Notes:**

- Non-repetitive, pulse width $\leq 100\ \mu\text{s}$, $T_C = 25^{\circ}\text{C}$.
- Input pins shorted together and output pins shorted together.
- Input-output potential applied momentarily, not a steady state operating condition.
- Rise time is measured from 10% to 90% of load current (90% to 10% of V_O). Fall time is measured from 90% to 10% of load current (10% to 90% of V_O).
- The user should apply the appropriate transient suppression technique to the output terminals of the relay when the loads are inductive enough to generate voltage spikes.

Micropac Industries cannot assume any responsibility for any circuits shown or represent that they are free from patent infringement. Micropac reserves the right to make changes at any time in order to improve design and to supply the best product possible.

INPUT	OUTPUT
ON	ON
OFF	OFF

Figure 1. Truth Table

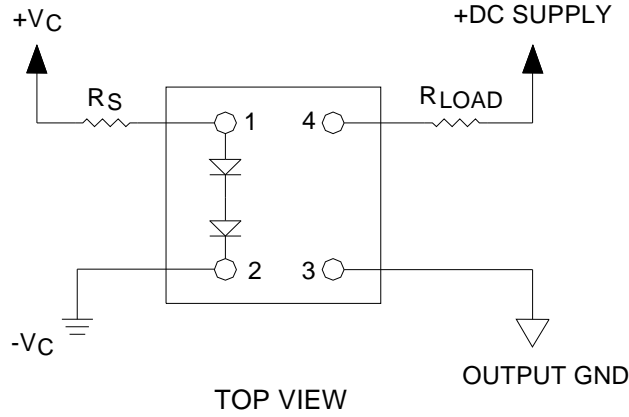

Figure 2. Terminal Connections

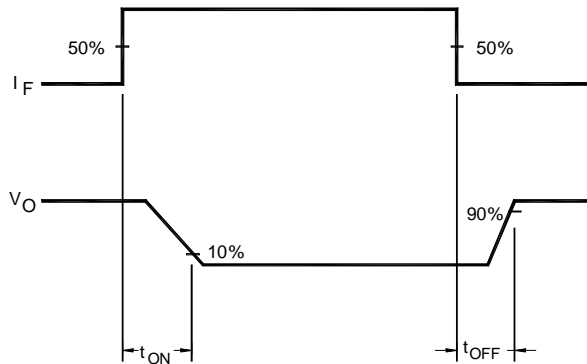
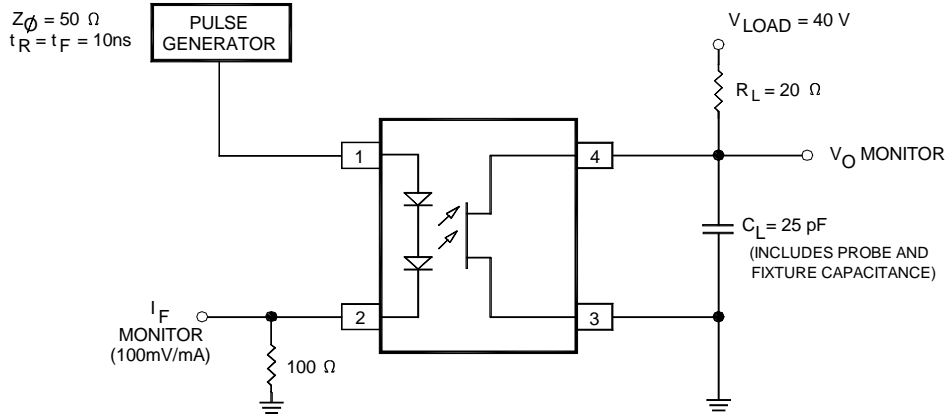
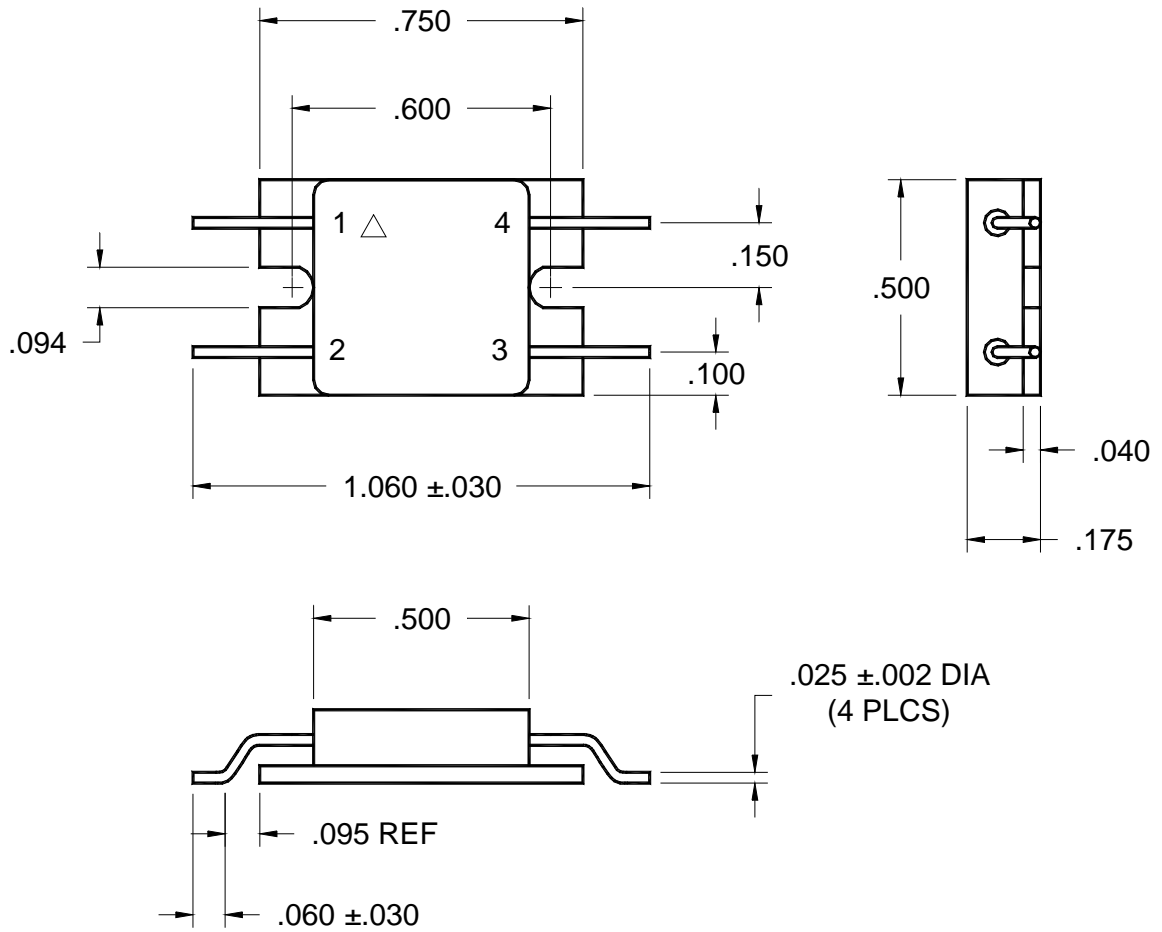

Figure 3. Switching Waveforms and Test Circuits

Micropac Industries cannot assume any responsibility for any circuits shown or represent that they are free from patent infringement. Micropac reserves the right to make changes at any time in order to improve design and to supply the best product possible.

CASE OUTLINE



Micropac Industries cannot assume any responsibility for any circuits shown or represent that they are free from patent infringement. Micropac reserves the right to make changes at any time in order to improve design and to supply the best product possible.