

### FEATURES

**Complete Single Chip GSM Processor**  
**Channel Codec Subsystem including**

- Channel Coder/Decoder
- Interleaver/De-interleaver
- Encryption/Decryption

**Control Processor Subsystem including**

- 16-bit Control Processor (H8/300H)
- Parallel and Serial Display Interface
- Keypad Interface
- EEPROM Interface
- SIM-Interface

- Universal System Connector Interface
- Interface to AD6425

- Control of Radio Subsystem
- Programmable backlight duty cycle
- Real Time Clock with Alarm
- Battery ID Chip Interface

**DSP Subsystem including**

- 16-bit DSP with ROM coded firmware for Full rate Speech Encoding/Decoding (GSM 06.10)
- Enhanced Full Rate Speech Encoding/Decoding (GSM 06.60)
- Equalization with 16-state Viterbi (Soft Decision)
- DTMF and Call Progress Tone Generation

**Power Management of Mobile Radio**

- Slow Clocking scheme for low Idle Mode current
- Ultra Low Power Design

**On-chip GSM Data Services up to 14.4 kbit/s**

**JTAG Test Interface**

**2.4V to 3.3V Operating Voltage**

**144-Lead LQFP and 144-Lead PBGA packages**

### APPLICATIONS

**GSM 900 / DCS1800 / PCS1900 Mobile Stations (MS)**  
**Compliant to Phase 1 and Phase 2 specifications**

### GENERAL DESCRIPTION

The AD6426 Enhanced GSM Processor (EGSMP) is the central component of the highly integrated AD20msp425 GSM Chipset. Offering a low total chip count, low bill of materials cost and long talk and standby times, the chipset offers designers a straightforward route to a highly competitive product in the GSM/DCS1800 market.

The EGSMP performs all the baseband functions of the Layer 1 processing of the GSM air interface. This includes all data encoding and decoding processes as well as timing and radio sub-system control functions.

The EGSMP supports full rate and enhanced full rate speech traffic as well as a full range of data services including F14.4.

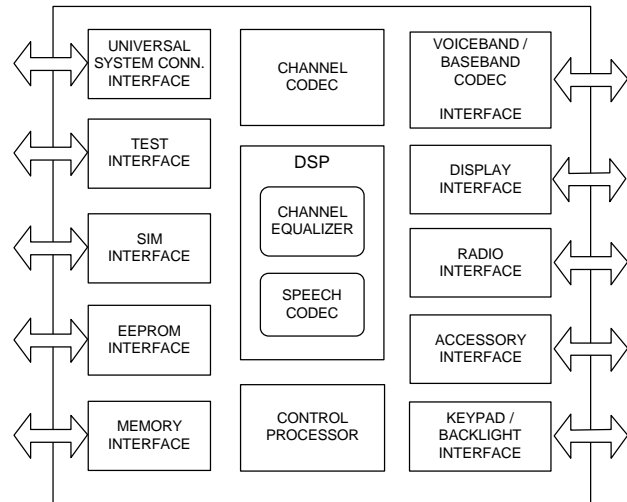

Figure 1. Functional Block Diagram

In addition, the EGSMP supports both A5/1 and A5/2 encryption algorithms as well as operation in non-encrypted mode.

The EGSMP integrates a high performance 16-bit microprocessor (Hitachi H8/300H), that supports all the GSM terminal software, including Layer 1, 2 and 3 of the GSM protocol stack, the MMI and applications software such as data services, test and maintenance.

The use of the standard H8 processor allows the use of HIOS, the Hitachi real time kernel, as well as a full range of software development tools including C compilers, debuggers and in-circuit emulators. The EGSMP also integrates a high performance 16-bit Digital Signal Processor (DSP), which provides speech transcoding and supports all audio functions in both transmit and receive. In receive it equalizes the received signal using a 16-state (Viterbi) soft decision equalizer.

The EGSMP interfaces with all the peripheral sub-systems of the terminal, including the keypad, memories, display driver, SIM, DTE and DTA data services interface and radio. It also has a general purpose interface that can be used to support an external connection to a car kit or battery charger.

The EGSMP interfaces with the AD6425 or the AD6421 Voiceband/Baseband Codec through a dedicated serial port.

### ORDERING GUIDE

Model	Temperature Range	Package
AD6426XST	-25°C to +85°C	144-Lead LQFP
AD6426XB	-25°C to +85°C	144-Lead PBGA

This Information applies to a product under development. Its characteristics and specifications are subject to change without notice. Analog Devices assumes no obligation regarding future manufacture unless otherwise agreed to in writing. No responsibility is assumed by Analog Devices for its use; nor for any infringements of patents or other rights of third parties which may result from its use. No license is granted by implication or otherwise under any patent or patent rights of Analog Devices.

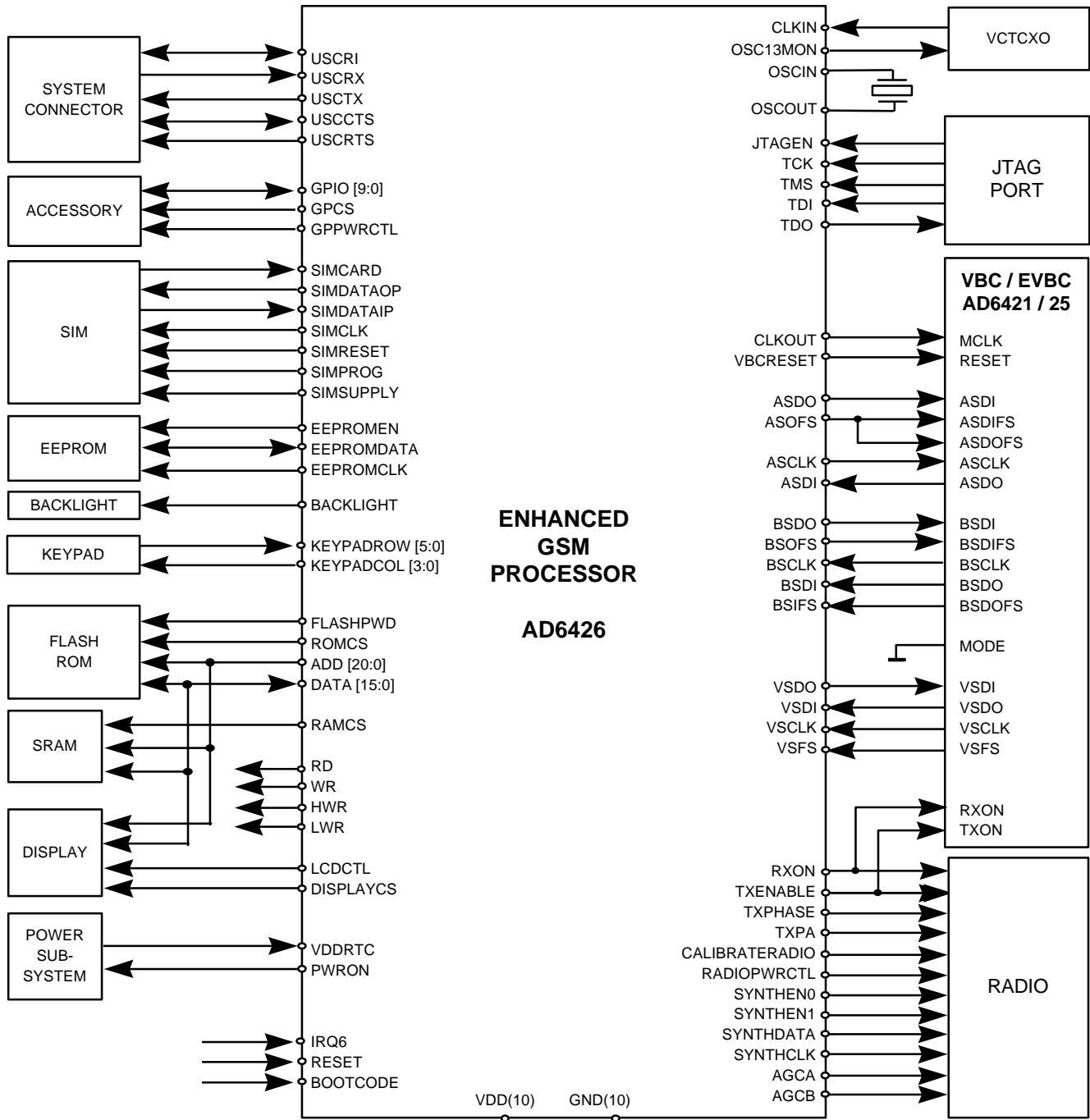

Figure 2. External Interfaces of the AD6426

This Information applies to a product under development. Its characteristics and specifications are subject to change without notice. Analog Devices assumes no obligation regarding future manufacture unless otherwise agreed to in writing. No responsibility is assumed by Analog Devices for its use; nor for any infringements of patents or other rights of third parties which may result from its use. No license is granted by implication or otherwise under any patent or patent rights of Analog Devices.

Table of Contents

GENERAL DESCRIPTION .....	1	Memory Interface.....	34
PIN FUNCTIONALITY ( Normal Mode).....	4	Radio Interface .....	35
OVERVIEW.....	7	High Speed Logging Interface .....	36
FUNCTIONAL PARTITIONING .....	7	Data Interface .....	37
Channel Codec Sub-System .....	7	Test Interface.....	38
Processor Sub-System.....	8	EVBC Interface ASPORT .....	39
DSP Sub-System.....	8	EVBC Interface BSPORT .....	40
Speech Transcoding .....	8	EVBC Interface VSPORT .....	41
Equalization .....	8	Parallel Display Interface .....	42
Audio Control .....	8	Serial Display Interface.....	43
Tone Generation .....	8	PACKAGING.....	44
Automatic Frequency Control (AFC) .....	8	LQFP Pin Locations.....	44
Automatic Gain Control (AGC).....	8	PBGA Pin Locations .....	45
REGISTERS.....	9	LQFP Outline Dimensions .....	47
GENERAL CONTROL.....	14	PBGA Outline Dimensions .....	48
Clocks .....	14		
Slow Clocking .....	14		
Real Time Clock and Alarm.....	14		
Reset .....	15		
Interrupts .....	15		
NMI.....	15		
Wait .....	16		
Automatic Booting .....	16		
Power Control.....	16		
INTERFACES .....	16		
Memory Interface.....	16		
EEPROM Interface .....	16		
SIM Interface.....	17		
Accessory Interface .....	17		
Universal System Connector Interface .....	18		
Operating modes of the USC.....	18		
Buffered UART Mode (Bootling/Data Services).....	18		
Keypad / Backlight / Display Interface .....	19		
Battery ID Interface.....	20		
EVBC Interface .....	20		
Radio Interface .....	22		
Dual Band Control .....	22		
Tx Timing Control .....	23		
Rx Timing Control .....	24		
Synthesizer Control.....	24		
AGC Control.....	25		
TEST INTERFACE .....	27		
JTAG Port.....	27		
Debug Port Interface .....	29		
MODES OF OPERATION.....	29		
Normal Mode (Mode A) .....	29		
Emulation Mode (Mode D).....	29		
FEATURE MODES.....	30		
DAI Mode.....	30		
High Speed Logging.....	30		
SPECIFICATIONS .....	32		
General.....	32		
ABSOLUTE MAXIMUM RATINGS .....	32		
TIMING CHARACTERISTICS.....	33		
Clocks .....	33		

This Information applies to a product under development. Its characteristics and specifications are subject to change without notice. Analog Devices assumes no obligation regarding future manufacture unless otherwise agreed to in writing. No responsibility is assumed by Analog Devices for its use; nor for any infringements of patents or other rights of third parties which may result from its use. No license is granted by implication or otherwise under any patent or patent rights of Analog Devices.

PIN FUNCTIONALITY ( Normal Mode)

Group	Pin Name	Pins	I/O	Default / Alternative Function(s) *
General	CLKIN	1	I	13 MHz Clock Input
	RESET	1	I	Reset input
	IRQ6	1	I / I	Interrupt Request # 6 / Non-Maskable Interrupt (NMI) *
	OSC13MON	1	O	13 MHz Oscillator Power Control Signal
	BOOTCODE	1	I	Boot Code Enable
	VDD	10		Supply Voltage
	GND	10		Ground
Memory Interface	ADD19 : 0	20	O	Processor Address Bus
	GPO10	1	O / O	General Purpose Output 10 / Address (20) *
	DATA15 : 0	16	I/O	Processor Data Bus
	RD	1	O	Processor Read Strobe
	HWR	1	O	Processor High Write Strobe / Upper Byte Strobe
	LWR	1	O	Processor Low Write Strobe / Lower Byte Strobe
	WR	1	O	Processor Write Strobe
	FLASHPWD	1	O / I / O	FLASH Power Down / WAIT / General Purpose Output 11*
	RAMCS	1	O	External RAM Chip Select
ROMCS	1	O	External ROM Chip Select	
SIM Interface	SIMCARD	1	I / I/O	SIM Card Detect / General Purpose I/O 16 *
	SIMDATAOP	1	O	SIM Data Output
	SIMDATAIP	1	I	SIM Data Input
	SIMCLK	1	O	SIM Clock
	SIMRESET	1	O	SIM Reset
	SIMPROG	1	O / I/O	SIM Program Enable / General Purpose I/O 15 *
	SIMSUPPLY	1	O	SIM Supply Enable
EEPROM Interface	EEPROMDATA	1	I/O	EEPROM Data
	EEPROMCLK	1	O	EEPROM Clock / High Speed Logger Clock
	EEPROMEN	1	O	EEPROM Enable / High Speed Logger Frame Sync
Display / Backlight / Keypad Interface	DISPLAYCS	1	O	Display Controller Chip Select / Chip Enable
	LCDCTL	1	O	LCD Control / Serial Display Data Output
	BACKLIGHT	1	O	Backlight Control
	KEYPADROW5 : 0	6	I	Keypad Row Inputs
	KEYPADCOL3 : 0	4	O	Keypad Column Strobes (open drain, pull low)

\* Note: Functionality of these pins can be changed under software control.

This Information applies to a product under development. Its characteristics and specifications are subject to change without notice. Analog Devices assumes no obligation regarding future manufacture unless otherwise agreed to in writing. No responsibility is assumed by Analog Devices for its use; nor for any infringements of patents or other rights of third parties which may result from its use. No license is granted by implication or otherwise under any patent or patent rights of Analog Devices.

Pin Functionality ( NORMAL MODE)

Group	Pin Name	Pins	I/O	Default / Alternative Function(s) *
EVBC Interface	CLKOUT	1	O	Clock Output to EVBC
	EVBCRESET	1	O	EVBC Reset Output (also for Display reset)
ASPORT	ASDO	1	O	EVBC Auxiliary Serial Port Data Output
	ASOFS	1	O	EVBC Auxiliary Serial Port Output Framing Signal
	ASCLK	1	O	EVBC Auxiliary Serial Port Clock Output
	ASDI	1	I	EVBC Auxiliary Serial Port Data Input
BSPORT	BSDO	1	O	EVBC Baseband Serial Port Data Output
	BSOFS	1	O	EVBC Baseband Serial Port Output Framing Signal
	BSCLK	1	I	EVBC Baseband Serial Port Clock Input
	BSDI	1	I	EVBC Baseband Serial Port Data Input
	BSIFS	1	I	EVBC Baseband Serial Port Input Framing Signal
VSPORT	VSDO	1	O	EVBC Voiceband Serial Port Data Output
	VSDI	1	I	EVBC Voiceband Serial Port Data Input
	VSCLK	1	I	EVBC Voiceband Serial Port Clock Input
	VSFS	1	I	EVBC Voiceband Serial Port Framing Signal
Radio Interface	RXON	1	O	Receiver On
	TXPHASE	1	O	Switches between Rx and Tx
	TXENABLE	1	O	Transmit Enable / General Purpose Output 14 *
	TXPA	1	O / O	Power Amplifier Enable / General Purpose Output 12 *
	CALIBRATERADIO	1	O / O	Radio Calibration / General Purpose Output 13 *
	RADIOPWRCTL	1	O	Radio Power-Down Control
	SYNTHEN0	1	O	Synthesizer 1 Enable
	SYNTHEN1	1	O	Synthesizer 2 Enable / General Purpose Output 17 *
	SYNTHDATA	1	O	RF Serial Port Data
	SYNTHCLK	1	O	RF Serial Port Clock
	AGCA	1	O	AGC Gain Select / General Purpose Output 18
	AGCB	1	O	AGC Gain Select / General Purpose Output 19
Universal System Connector Interface	USCRI	1	I/O	USC Ring Indicator / Serial Clock / GPO20
	USCRX	1	I	USC Receive Data
	USCTX	1	O	USC Transmit Data / Baseband Serial Port Data Input
	USCCTS	1	I/O	USC Clear to Send / Serial Frame Sync / GPI22
	USCRTS	1	O	USC Ready to Send / GPO21

\* Note: Functionality of these pins can be changed under software control.

This Information applies to a product under development. Its characteristics and specifications are subject to change without notice. Analog Devices assumes no obligation regarding future manufacture unless otherwise agreed to in writing. No responsibility is assumed by Analog Devices for its use; nor for any infringements of patents or other rights of third parties which may result from its use. No license is granted by implication or otherwise under any patent or patent rights of Analog Devices.

Pin Functionality ( NORMAL MODE)

Group	Pin Name	Pins	I/O	Default / Alternative Function(s) *
Accessory Interface	GPIO0	1	I/O	General Purpose Inputs/Output 0
	GPIO1	1	I/O	General Purpose Inputs/Output 1 / Radio BANDSELECT1 *
	GPIO2	1	I/O	General Purpose Inputs/Output 2 / Radio BANDSELECT0 *
	GPIO3	1	I/O	General Purpose Inputs/Outputs 3 / Serial Display Address Output *
	GPIO4	1	I/O	General Purpose Inputs/Outputs 4 / Serial Display Clock Output *
	GPIO5	1	I/O	General Purpose Inputs/Outputs 5 / Battery ID Interface *
	GPIO6	1	I/O	General Purpose Inputs/Output 6 / VBIAS *
	GPIO7	1	I/O	General Purpose Inputs/Output 7 / Antenna Select *
	GPIO8	1	I/O	General Purpose Inputs/Output 8 / DEBUG UART Transmit Data *
	GPIO9	1	I/O	General Purpose Inputs/Output 9 / DEBUG UART Receive Data *
	GPCS	1	O	General Purpose Chip Select
Real Time Clock Interface	OSCIN	1	I	32.768 kHz Crystal Input
	OSCOUT	1	O	32.768 kHz Oscillator Output and Feedback to Crystal
	VDDRRTC	1		RTC Supply Voltage
	PWRON	1	O	Power ON/OFF Control
Test Interface	JTAGEN	1	I	JTAG Enable
	TCK	1	I	JTAG Test Clock / HSL Data 0
	TMS	1	I	JTAG Test Mode Select / HSL Data 1 / DAI Reset
	TDI	1	I	JTAG Test Data Input / HSL Data 3 / DAI Data 1
	TDO	1	O	JTAG Test Data Output / HSL Data 2 / DAI Data 0

\* Note: Functionality of these pins can be changed under software control.

This Information applies to a product under development. Its characteristics and specifications are subject to change without notice. Analog Devices assumes no obligation regarding future manufacture unless otherwise agreed to in writing. No responsibility is assumed by Analog Devices for its use; nor for any infringements of patents or other rights of third parties which may result from its use. No license is granted by implication or otherwise under any patent or patent rights of Analog Devices.

**OVERVIEW**

The GSM air interface has been formulated to provide high quality digital mobile communication. As well as supporting the traffic channels (speech and/or data), the air interface specifies a number of signaling channels that are used for call set up and communications between the network infrastructure and the mobile. These signaling channels provide the mobile specific features such as handover, as well as a number of other intelligent features.

The GSM system closely follows the OSI 7-layer model for communications. Specifically, GSM defines Layers 1, 2 and 3 of the protocols. The lowest level being Layer 1, or the Physical Layer. It is this part of the network processing for which the EGSM is responsible, performing some of the Layer 1 functions in dedicated hardware for minimum power consumption and some in software for increased flexibility.

Layer 1 covers those signal processing functions required to format the speech/data for transmission on the physical medium. Data must be structured to allow for identification, recovery and error correction so that the information can be supplied error free to the layer 2 sub-systems and to the traffic sources. In addition, the physical layer processing includes the timing of both transmit and receive data, the encryption of data for security purposes and the control of the Radio sub-system to provide timing and to optimize the radio frequency characteristics. An object code license to Layer 1 software is supplied with the AD20msp425 chipset.

**FUNCTIONAL PARTITIONING**

This datasheet gives only an overview about the functionality of the EGSM. The EGSM consists of three main elements; the Channel Codec and the Control Processor Sub-System including several interfaces and the DSP as shown in Figure 1. The Channel Codec is responsible for the Layer 1 channel coding and decoding of traffic and control information. The Processor Sub-system supports the software functions of the protocol stack and interfaces with the bus peripheral sub-systems of the terminal. The DSP performs the channel equalization and speech transcoding.

**Channel Codec Sub-System**

The Channel Codec processes data from two principal sources; traffic and signaling. The former is normally continuous and the latter determined on demand. Traffic comes in two forms; speech and user data. The various traffic sources and the signaling sources are all processed differently at the physical layer. Speech traffic data is supplied by the speech transcoder and the remaining data types are sourced from the Control Processor and interfaced via a dedicated data interface. The Channel Codec subsystem functional block diagram is shown in Figure 3.

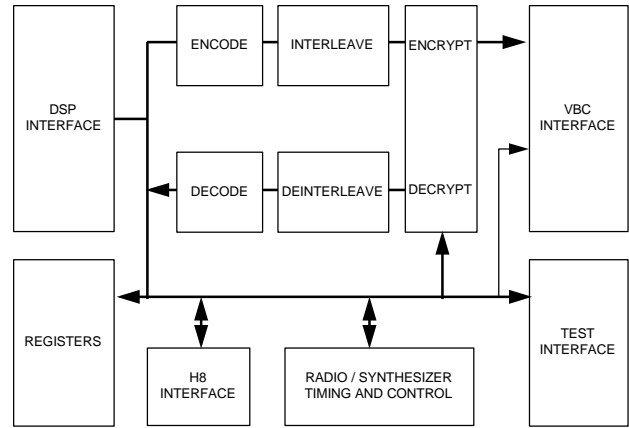

Figure 3. Channel Codec Subsystem

The transmit and receive functions of the Channel Codec are timed by an internal timebase that maintains accurate timing of all sub-systems. This timebase is aligned with the on-air receive signal and all system control signals, both internal and external, are derived from it.

The physical layer processing can be divided into 4 phases, two each for up- and downlink. The data in the transmit path undergoes an ENCODE phase and then a TRANSMIT phase. Similarly, data in the downlink path is termed the receive data and it undergoes a RECEIVE phase followed by a DECODE phase. The buffer between the ENCODE and TRANSMIT functions is the INTERLEAVE module that holds the data and permits the building of the transmit burst structure. Similarly the DEINTERLEAVE module forms the buffer between the RECEIVE and the DECODE processes.

Each of these four phases is controlled explicitly by the Control Processor via control registers that define the mode of operation of each sub-module and the data source they should process. Typically these control values are updated every TDMA frame in response to interrupts from the internal timebase.

The ENCODE process involves the incorporation of error protection codes. All data is sourced in packets and two forms of error coding applied; block coding (parity or Fire code) and convolution coding. The resultant data block is then written to the INTERLEAVE module where it is buffered in a RAM. Data is read from the interleave buffer memories contiguously but written in non-contiguous manner, thereby implementing the interleaving function. The TRANSMIT process uses a different time structure now associated with the on-air TDMA structure. The data is read from the INTERLEAVE module and formatted into bursts with the requisite timing. This involves adding fixed patterns such as the tail bits and training sequence code. The resultant burst is written to the external Baseband Converter where the modulation is performed and the output timed to the system timebase before transmission.

This Information applies to a product under development. Its characteristics and specifications are subject to change without notice. Analog Devices assumes no obligation regarding future manufacture unless otherwise agreed to in writing. No responsibility is assumed by Analog Devices for its use; nor for any infringements of patents or other rights of third parties which may result from its use. No license is granted by implication or otherwise under any patent or patent rights of Analog Devices.

A feature of the GSM system is the application, as part of the TRANSMIT process, of data encryption for the purpose of link security. After the INTERLEAVE module the data may be encrypted using the prescribed A5/1 or A5/2 encryption algorithm.

The RECEIVE function requires unmodulated baseband data from the equalizer. As necessary the data is decrypted and written to the DEINTERLEAVE module. This is conducted at TDMA frame rate, although precise timing is not necessary at this stage.

The DECODING process reads data from the DEINTERLEAVE module, inverting the interleave algorithm and decodes the error control codes, correcting and flagging errors as appropriate. The data also includes a measure of confidence expressed as two additional bits per received symbol. These are used in the convolution decoder to improve the error decoding performance. The resultant data is then presented to the original sources as determined by the control programming. The Channel Codec interfaces with the speech transcoder for speech traffic data and with an equalizer for recovered receive data. In the AD6426 the equalizer and speech transcoder are implemented in the DSP.

#### Processor Sub-System

The Processor Sub-System consists of a high performance 16-bit microcontroller together with a selection of peripheral elements. The processor is a version of the Hitachi H8/300H that has been developed to support GSM applications and which is well suited to support the Protocol Stack and Application Layer software.

#### DSP Sub-System

The DSP Sub-System consists of a high performance 16-bit digital signal processor (DSP) with integrated RAM and ROM memories. The DSP performs two major tasks: speech transcoding and channel equalization. Additionally several support functions are performed by the DSP. The instruction code, which advises the DSP to perform these tasks, is stored in the internal ROM. The DSP sub-system is completely self-contained, no external memory or user-programming is necessary.

#### Speech Transcoding

In Full Rate mode the DSP receives the speech data stream from the EVBC and encodes the data from 104 kbit/s to 13 kbit/s. The algorithm used is Regular Pulse Excitation, with Long Term Prediction (RPE-LTP) as specified in the 06-series GSM Recommendations.

In Enhanced Full Rate mode, the DSP encodes the 104 kbit/s speech data into 12.2 kbit/s (speech) +0.8 kbit/s (CRC and repetition bits) as additionally specified in the Phase 2 version of the 06-series GSM Recommendations. In both modes, the DSP also performs the appropriate voice activity detection and discontinuous transmission (VAD/DTX) functions.

Alternatively the DSP receives encoded speech data from the channel codec sub-system including the Bad Frame Indicator (BFI). The Speech decoder supports a Comfort Noise Insertion (CNI) function that inserts a predefined silence descriptor into the decoding process. The resulting data, at 104 kbit/s, is transferred to the EVBC.

#### Equalization

The Equalizer recovers and demodulates the received signal and establishes local timing and frequency references for the mobile terminal as well as RSSI calculation. The equalization algorithm is a version of the Maximum Likelihood Sequence Estimation (MLSE) using the Viterbi algorithm. Two confidence bits per symbol provide additional information about the accuracy of each decision to the channel codec's convolutional decoder. The equalizer outputs a sequence of bits including the confidence bits to the channel codec sub-system.

#### Audio Control

The DSP subsystem is also responsible for the control of the audio path. The EVBC provides two audio inputs and two audio outputs, as well as a separate buzzer output, which are switched and controlled by the DSP. Furthermore the EVBC provides for variable gain and sensitivity which is also controlled by the DSP under command of the Layer 1 software.

#### Tone Generation

All alert signals are generated by the DSP and output to the EVBC. These alerts can be used for the buzzer or for the earpiece. The tones used for alert signals can be fully defined by the user by means of a description which provides all the parameters required such as frequency content and duration of components of the tone. The tone descriptions are provided by the Layer 1 software.

#### Automatic Frequency Control (AFC)

The detection of the frequency correction burst provides the frequency offset between the mobile terminal and the received signal. This measure is supplied to the Layer 1 software which then requests a correction of the master clock oscillator frequency via the AFC-DAC in the EVBC. In order to do so the Layer 1 software includes a transfer function for the oscillator frequency against the voltage applied. The DSP provides the measurements for the AFC.

#### Automatic Gain Control (AGC)

The DSP is also responsible for making measurements of the power in the received signal. This is used for a number of functions including RSSI measurement, adjacent channel monitoring and AGC. The Layer 1 software passes the requested gain level to the DSP, which then analyzes the received signal and generates an AGC control signal. Depending on the radio architecture, this control signal will be used in digital form or, converted by the AD6425 in analog form.

This Information applies to a product under development. Its characteristics and specifications are subject to change without notice. Analog Devices assumes no obligation regarding future manufacture unless otherwise agreed to in writing. No responsibility is assumed by Analog Devices for its use; nor for any infringements of patents or other rights of third parties which may result from its use. No license is granted by implication or otherwise under any patent or patent rights of Analog Devices.



**REGISTERS**

The AD6426 contains 88 Channel Codec Control Registers, 69 H8 Peripheral Registers mapped into the Channel Codec address space starting at 8000h. All registers are normally accessed by the Layer 1 software provided with the AD20msp425 chipset. The user is not expected to read or write to any registers other than through the Layer 1 software. Therefore only a limited description of these registers is given here to ease the understanding of the functional behavior of the AD6426. Only registers which can be modified or monitored by the user under control of the Layer 1 software are shown. The Channel Codec Control Registers are listed in Table 1, and the H8 Peripheral Control Registers in Table 3

Address		Name	
72	48 H	SYNTHESIZER PROGRAM	R/W
73	49 H	TXPA OFFSET 1	R/W
74	4A H	TXPA OFFSET 2	R/W
75	4B H	TXPA WIDTH 1	R/W
76	4C H	TXPA WIDTH 2	R/W
77	4D H	IRQ ENABLE	R/W
78	4E H	IRQ LATCH	RMW
79	4F H	CC GPIO	R/W
88	58 H	ccGPO	R/W

A description of the Channel Codec Control Register contents is shown in Table 2, and of the H8 Peripheral Registers in Table 4.

*Table 1. CC Control Registers*

Address		Name	
0	00 H	SYSTEM	R/W
2	02 H	RADIO CONTROL	R/W
4	04 H	BSIC	R/W
5	05 H	TSC	R/W
6	06 H	TRAFFIC MODE	R/W
7	07 H	DAI	R/W
8	08 H	EEPROM	R/W
9	09 H	KEYPAD COLUMN	R/W
10	0A H	KEYPAD ROW	RD
28	1C H	EVBC SERIAL 1	RMW
29	1D H	EVBC SERIAL 2	RMW
30	1E H	EVBC IF CONTROL	R/W
35	23 H	RESET	R/W
37	25 H	SYNTH BIT COUNT	R/W
38	26 H	SYNTH CONTROL	R/W
39	27 H	ERROR COUNT	RMW
40	28 H	SYNTHESIZER 1	WR
41	29 H	SYNTHESIZER 2	WR
42	2A H	SYNTHESIZER 3	WR
43	2B H	SYNTHESIZER 4	WR
44	2C H	POWER CONTROL INT	R/W
45	2D H	POWER CONTROL EXTERNAL	R/W
46	2E H	SWRESET 1	R/W
47	2F H	SWRESET 2	R/W
48	30 H	INTERRUPT COUNTER	R/W
49	31 H	BBC TX ADDRESS	R/W
50	32 H	BACKLIGHT	WR
51	33 H	VERSION CONTROL	RD

This Information applies to a product under development. Its characteristics and specifications are subject to change without notice. Analog Devices assumes no obligation regarding future manufacture unless otherwise agreed to in writing. No responsibility is assumed by Analog Devices for its use; nor for any infringements of patents or other rights of third parties which may result from its use. No license is granted by implication or otherwise under any patent or patent rights of Analog Devices.

Table 2. CC Control Register Contents

#	7	6	5	4	3	2	1	0	
0	Autocalibrate		Backlight 1	Test Data Enable	Calibrate Radio	Encryption Type	Encrypt Key Load		
2	Tx Monitor Enable	Tx Phase Polarity	Rx Radio Control Polarity	Tx Radio Control Polarity	Tx PHASE Enable	Monitor Enable	Receive Enable	Transmit Enable	
4	Base Station Identity Code								
5	Training Sequence Code								
6	TxPA Polarity	INT COUNT[8]	OCE OVERRIDE	Interrupt Counter Override	Autocalibration Type	Traffic Frame Enable	Decryption Enable	Encryption Enable	
7	BAND ENABLE			NMI Select	GPO10 Data	GPO10 Select	Data Ser. Select	DAIRESET	
8				EEPROM Data Output Enable		EERPOM Clock	EEPROM Enable	EERPOM Data	
9	Keypad Column								
10	Keypad Row								
28	EVBC Serial Port ( 15 : 8 )								
29	EVBC Serial Port ( 7 : 0 )								
30	Tx Data Delay					EVBC Rx-Buff. full	EVBC Tx-Buf.empty		
35					EVBC Reset	DSP Reset		CC Reset	
37	Isolate Synthesizer	Config. Dynam. Synthesizer	Synthesizer Interface active	Synthesizer Bit Count					
38	Synthesizer Enable Polarity	Synthesizer Enable Type	Synthesizer Clock Polarity			Synthesizer Load Dynamic 1	Synthesizer Load Dynamic 2	Synthesizer Clock	
39	Error Count								
40	Synthesizer (31: 24)								
41	Synthesizer (23: 16)								
42	Synthesizer (15: 8)								
43	Synthesizer (7: 0)								
44	Backlight Duty Cycle					Synth. Interface Power Enable	DSP Interface Power Enable	Encryption Power Enable	
45		Coprocessor Power Control	Output Clock Enable	GP Power Control		DSP Power Control	Radio Power Control		
46					Encryption SW-Reset	EVBC Interface SW-Reset	DSP Interface SW-Reset	Synthes. Interface SW-Reset	
47				INT CNT RST	Decode SW-Reset	Deinterleave SW-Reset	interleave SW-Reset	Encode SW-Reset	
48	Interrupt Counter								
49		EVBC Read	EVBC Tx Address						
50						Modulate 1	Backlight LED Control		
51	Version								
72			Disable Synth.1	Disable Synth. 0	Synt. Enable Sel.	Synt. Mode	Pin Mode		
73							TD ( 9 : 8 )		
74	TD ( 7 : 0 )								
75							TW ( 9 : 8 )		
76	TW ( 7 : 0 )								
77	GPO11 Data	GPO11 Select	IRQ5 Enable	IRQ4 Enable	IRQ3 Enable	IRQ2 Enable	FLASHPWD dis.	NMI Edge Pol.	
78			IRQ5 active	IRQ4 active	IRQ3 active	IRQ2 active			
79			GPI09 OP En	GPI08 OP En				GPI09 Data	GPI08 Data
88		GPO19 Sel	GPO18 Sel	GPO17 Sel		GPO19	GPO18	GPO17	

This Information applies to a product under development. Its characteristics and specifications are subject to change without notice. Analog Devices assumes no obligation regarding future manufacture unless otherwise agreed to in writing. No responsibility is assumed by Analog Devices for its use; nor for any infringements of patents or other rights of third parties which may result from its use. No license is granted by implication or otherwise under any patent or patent rights of Analog Devices.

Table 3. H8 Peripheral Control Registers

Address		Name	
0	8000h	SMSMR	R/W
1	8001h	SMBRR	R/W
2	8002h	SMSCR	R/W
3	8003h	SMDR	W
4	8004h	SMSSR	R/W
5	8005h	SMDR	R
6	8006h	SMSCMR	R/W
10	8010h	BUFRBR	R
10	8010h	BUFTHR	W
10	8010h	BUFDLL	R/W
11	8011h	BUFIER	R/W
11	8011h	BUFDLM	R/W
12	8012h	BUFIIR	R
12	8012h	BUFFCR	W
13	8013h	BUFLCR	R/W
14	8014h	BUFMCR	R/W
15	8015h	BUFLSR	R/W
16	8016h	BUFMSR	R/W
17	8017h	BUFSCR	R/W
18	8018h	UIBRBR	R
18	8018h	UIBTHR	W
19	8019H	UIBSSR	R/W
26	801AH	UIBER	R
27	801BH	UIBTSR	R
28	801CH	UIBTLR	R/W
29	801Dh	UIBBLR	R
32	8020h	FIXRBR	R
32	8020h	FIXTHR	W
32	8020h	FIXDLL	R/W
33	8021h	FIXIER	R/W
33	8021h	FIXDLM	R/W
34	8022h	FIXIIR	R
35	8023h	FIXLCR	R/W
36	8024h	FIXMCR	R/W
37	8025h	FIXLSR	R/W
38	8026h	FIXMSR	R/W
39	8027h	FIXSCR	R/W
48	8030h	SCCR	R/W
49	8031h	SPSSR	R/W
50	8032h	SDIR1 (MS)	R
51	8033h	SDIR0 (LS)	R
52	8034h	SDOR1 (MS)	W
53	8035h	SDOR0 (LS)	W

Address		Name	
64/65	8040/1h	DISPDDR	W
66	8042h	DISPCR	R/W
67	8043h	DDOR	W
68	8044h	DDIR	R
69	8045h	DRR	R/W
72	8048h	WDTR	W
80	8050h	MEM IF	R/W
81	8051h	PERST	R/W
82	8052h	PERCR	R/W
84	8054h	TAR	R/W
85	8055h	PERCLK	R/W
96	8060h	RTCTR1	R/W
97	8061h	RTCTR2	R/W
98	8062h	RTCTR3	R/W
99	8063h	RTCTR4	R/W
100	8064h	RTCTR5	R/W
101	8065h	RTCAR1	R/W
102	8066h	RTCAR2	R/W
103	8067h	RTCAR3	R/W
104	8068h	RTCCR	R/W
105	8069h	RTCSRZ	R/W
106	8074h	SERDISPLAY/NMI	R/W

This Information applies to a product under development. Its characteristics and specifications are subject to change without notice. Analog Devices assumes no obligation regarding future manufacture unless otherwise agreed to in writing. No responsibility is assumed by Analog Devices for its use; nor for any infringements of patents or other rights of third parties which may result from its use. No license is granted by implication or otherwise under any patent or patent rights of Analog Devices.

Table 4. H8 Peripheral Register Contents

#	7	6	5	4	3	2	1	0
0				ODD				
1					BRR[3:0]			
2	TIE	RIE	TE	RE	AE	DATEN	CLKPOL	CLKEN
3	Transmit[7:0]							
4	TDRE	RDRF	ORER	ERS	PER	TEND		
5	Receive[7:0]							
6								
10	RxData[7:0]							
10	TxData[7:0]							
10	BRR[7:0]							
11					EDSSI	ELSI	ETBEI	ERBFI
11	BRR[15:8]							
12	FIFO ST	FIFO ST			InterruptID[2:0]			Int Pend
12	RxLevel[1:0]				DMA	TX FIFO	RX FIFO	FIFO EN
13	DLAB	SET BRK	Stick Par.	Ev. Parity	Parity EN	Stop Bits	WLS[1:0]	
14				Loop	Out2	Out1	RTS	DTR
15	Error Rx FIFO	TEMT	THRE	Break Interrupt	Framing Error	Parity Error	Overrun Error	Data Ready
16	DCD	RI	DSR	CTS	DDCD	TERI	DDSR	DCTS
17	SCR[7:0]							
18	RxData[7:0]							
18	TxData[7:0]							
19						MRESET	UIB Enable	PROC
26			TE	RE	FE	PE	BI	OE
27					MODEM	TX Level	RX Time	RX Level
28	Tx Trigger Level [3:0]				Rx Trigger Level [3:0]			
29	Chars in TX Buffer [3:0]				Chars in Rx Buffer [3:0]			
32	RxData[7:0]							
32	TxData[7:0]							
32	BRR[7:0]							
33					EDSSI	ELSI	ETBEI	ERBFI
33	BRR[15:8]							
34	FIFO ST	FIFO ST			InterruptID[2:0]	Int Pend	R	
35	DLAB	SET BRK	Stick Par.	Ev. Parity	Parity EN	Stop Bits	WLS[1:0]	R/W
36				Loop	Out2	Out1	RTS	DTR
37	Error Rx FIFO	TEMT	THRE	Break Interrupt	Framing Error	Parity Error	Overrun Error	Data Ready
38	DCD	RI	DSR	CTS	DDCD	TERI	DDSR	DCTS
39	SCR[7:0]							
48	TEST	RX MODE	CLOCK	TX ENABLE	CROSSPOINT SWITCH	UCONN SWITCH	R/W	
49		SDORIE	SDIROE IE	SDIRIE		SDOR EMT	SDIR OE	SDIR FULL
50	Receive[15:8]							
51	Receive[7:0]							
52	Transmit[15:8]							
53	Transmit[7:0]							
64/65	Data[7:0]							

This Information applies to a product under development. Its characteristics and specifications are subject to change without notice. Analog Devices assumes no obligation regarding future manufacture unless otherwise agreed to in writing. No responsibility is assumed by Analog Devices for its use; nor for any infringements of patents or other rights of third parties which may result from its use. No license is granted by implication or otherwise under any patent or patent rights of Analog Devices.

H8 Peripheral Register Contents (Continued)

#	7	6	5	4	3	2	1	0
66					SDISP POL	DISP CLKEN	CLK FREQ	DDREMT
67	Transmit Data [7:0]							
68	Receive Data [7:0]							
69	Reset Data [7:0]							
72	WDT[7:0]							
80	TEST CLK	Unused	Unused	UART SEL	DALLAS EN	RAM SEL7	DISP	SRAM16
81	WDT INT	RTC INT	KEYINT	DALLAS INT	FA INT	UA INT	SSINT	MONINT
82	WDT IE	RTC IE	KEY IE	DALLAS IE	FA IE	UA IE	SS IE	MONIE
84	Test Key[7:0]							
85			USCCLK EN	BUCLK EN	FUCLK EN	DSPPLL[2:0]		
96	TR[1]							
97	TR[2]							
98	TR[3]							
99	TR[4]							
100	TR[5]							
101	AR[1]							
102	AR[2]							
103	AR[3]							
104	INTEN	TIMWEN	ALAWEN	PWRUEN	AGCENN	FBENN	Unused	Unused
105	INT	TIMER	ALARM		APWRUP	OSCFAIL	32K PRESENT	TESTOUT
106			TXENABLE NMI	SERDISP MODE				

This Information applies to a product under development. Its characteristics and specifications are subject to change without notice. Analog Devices assumes no obligation regarding future manufacture unless otherwise agreed to in writing. No responsibility is assumed by Analog Devices for its use; nor for any infringements of patents or other rights of third parties which may result from its use. No license is granted by implication or otherwise under any patent or patent rights of Analog Devices.

**GENERAL CONTROL**

**Clocks**

**Clock Input**

The AD6426 requires a single 13 MHz, low level clock signal, which has to be provided at the pin CLKIN. For proper operation a signal level of 250 mV<sub>PP</sub> minimum is required. This feature eases system design and reduces the need for external clock buffering. Only minimal external components are required as shown in Figure 4.

The internal clock buffer can accept any regular waveform as long as it can find voltage points in the signal, for which a 50% duty cycle can be determined. This condition is met for sinewaves, triangles, or slew-limited square waves. Dedicated circuitry searches for these points and generates the respective bias voltage internally.

The external capacitor (1nF) decouples the bias voltage of the clock signal generated by the oscillator from the internally generated bias voltage of the clock buffer circuitry.

The LC-filter shown is optional. It ensures, that the input signal is “well behaved” and sinusoidal. Additionally it filters out harmonics and noise, that may be on top of the pure 13 MHz signal.

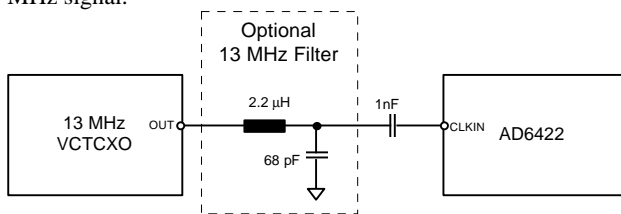

Figure 4. Clock Input Circuitry

**Clock Output**

The input clock drives both the H8 and the Channel Codec directly. A gated version, controlled by the *Output Clock Enable* flag in CC Control Register 45, drives the CLKOUT pin of the EVBC interface. The stand-by state of CLKOUT is logic zero. The CLKOUT output will be active on reset.

**Slow Clocking**

To reduce power consumption of AD20msp425 solutions, a new slow clocking scheme has been designed into the AD6426. This scheme allows the VCTCXO to be powered down between paging blocks during Idle Mode and for a 32.768kHz oscillator to keep the time reference during this period. Only a common 32.768kHz watch crystal is required to take advantage of this scheme. As in previous generations, power consumption is also kept to a minimum using asynchronous design techniques and by stopping all unnecessary clocks.

Layer 1 software and logic built into the AD6426 are responsible for maintaining synchronization and calibration of the slow clock and ensure the validity of the time reference

under all circumstances. The active-high OSC13MON output is prevented from becoming inactive if the 32.768kHz signal is not present. The following table describes the functionality of the relevant pins.

Name	I/O	Function
OSCIN	I	32.768kHz Crystal Input
OSCOUT	O	32.768kHz Oscillator Output
OSC13MON	O	13 MHz Oscillator Power Control
PWRON	O	Power ON/OFF Control

The following table lists the recommended specification for a 32kHz crystal.

Parameter	Min	Typ	Max	Units
ESR			50	kΩ
Shunt Capacitance			2	pF
Load Capacitance	6	12.5	30	pF
Turnover Temperature (T <sub>o</sub> )		25		°C
Parabolic Curvature Constant (K)		0.040		ppm/°C

**Real Time Clock and Alarm**

The AD6426 provides a simple Real Time Clock (RTC) using the 32.768kHz clock input. A 40 bit counter allows for more than one year of resolution. The RTC module contains a 32.768kHz on chip oscillator buffer designed for very low power consumption and a set of registers for a timer, alarm, control and status functions.

The RTC circuit is supplied by two sources; a VDDRTC supply pin and the main system VDD. It is the handset designer’s responsibility to provide suitable switching between the main system VDD and a backup supply to ensure the RTC module is permanently powered.

The VDDRTC pin is intended to interface to a backup battery circuit or charge holding network in order for the RTC to maintain timing accuracy when the main battery is removed and the handset is powered down.

The user can set an alarm time at which the handset powers up. If an alarm time is set, the current time matches the alarm time, and the power on alarm feature is enabled, the handset is powered up by asserting the PWRON pin for a period of approximately 2 seconds.

This Information applies to a product under development. Its characteristics and specifications are subject to change without notice. Analog Devices assumes no obligation regarding future manufacture unless otherwise agreed to in writing. No responsibility is assumed by Analog Devices for its use; nor for any infringements of patents or other rights of third parties which may result from its use. No license is granted by implication or otherwise under any patent or patent rights of Analog Devices.

The VDDRTC was designed to interface with either a:

- Lithium Battery or
- Capacitor in the range of 0.4F (maximum for ~24 hours standby) to 8mF (~30 minutes standby)

**Reset**

The AD6426 is reset by setting the RESET pin to GND. This will reset the H8-processor, the Channel Codec, the internal DSP as well as the LCD controller interface and Boot ROM logic. Both the DSP and the Channel Codec will be held in reset until the RESET register is written to by the H8. At least 50 CLKIN cycles must elapse before deasserting the RESET pin and at least a further 100 cycles before writing to the RESET register.

For reset at power up, the DSP must be held in reset for at least 2000 clock cycles to enable the internal PLL to lock.

The RESET CC Control Register 35 contains the following flags:

Bit	Function
3	<i>EVBC Reset</i>
2	<i>DSP Reset</i>
0	<i>Channel Codec Reset</i>

Additionally 8 functional modules can be reset under control of the two SWRESET registers:

Bit	SWRESET 1 CC Control Register 46
3	<i>Encryption Software Reset</i>
2	<i>EVBC Interface Software Reset</i>
1	<i>DSP Interface Software Reset</i>
0	<i>Synthesizer Interface Software Reset</i>

Bit	SWRESET 2 CC Control Register 47
3	<i>Decode Software Reset</i>
2	<i>Deinterleave Software Reset</i>
1	<i>Interleave Software Reset</i>
0	<i>Encode Software Reset</i>

The JTAG circuitry is reset by a power-on reset mechanism. Further resets must be done by asserting the TMS input high for at least five TCK clock cycles. When JTAG compliance is re-enabled, the JTAG is reset forcing the AD6426 into its normal mode of operation, selecting the BYPASS register by default.

The H8 fetches its program start vector from location 0x0000 in segment zero. This can either be from external ROM or internal Boot ROM, depending on the status of the BOOTCODE pin.

**Interrupts**

The interrupts are controlled by the two CC Control Registers 77 and 78. These registers only apply to Emulation Mode, in that they define which of the interrupts are able to assert CCIRQ2.

Bit	IRQ ENABLE CC Control Register 77
5	<i>IRQ 5 Enable</i>
4	<i>IRQ 4 Enable</i>
3	<i>IRQ 3 Enable</i>
2	<i>IRQ 2 Enable</i>

Bit	IRQ LATCH CC Control Register 78
5	<i>IRQ 5 active</i>
4	<i>IRQ 4 active</i>
3	<i>IRQ 3 active</i>
2	<i>IRQ 2 active</i>

**NMI**

The non-maskable interrupt NMI input of the H8 processor is multiplexed with the IRQ6 pin. IRQ6 is the default function, though asserting the NMI Select flag in CC Control Register 7 will select the NMI function. When not selected, NMI will be tied off high internally, though it remains driven by the JTAG port for test purposes. The signal is programmable to be edge or level sensitive. It defaults to falling edge. The edge polarity can be changed by programming the H8. However, if FLASHPWD is used then the same setting must be applied to CC Control Register 77. The default of zero implies falling edge sensitive. This way NMI going active can correctly deassert FLASHPWD. The NMI can be used for test purposes or user defined features. NMI is capable of bringing the control processor out of software standby mode and therefore suitable for functions such as alarm inputs, power management etc. During manufacture the NMI can be used to trigger special test code.

In addition NMI can be generated internally thus freeing up the IRQ6 PIN. In this mode the TXENABLE NMI will occur on the rising edge of the TXENABLE as seen at the pin. The H8 should be set up for a negative edge NMI in this case. Setting bit 5 in the SERDISPLAY/NMI H8 Peripheral Control Register 106 to a ONE enables the TXENABLE NMI. However, the Layer 1 Software must program the external INT pin to INT6 before the register bit is set.

This Information applies to a product under development. Its characteristics and specifications are subject to change without notice. Analog Devices assumes no obligation regarding future manufacture unless otherwise agreed to in writing. No responsibility is assumed by Analog Devices for its use; nor for any infringements of patents or other rights of third parties which may result from its use. No license is granted by implication or otherwise under any patent or patent rights of Analog Devices.

**Wait**

The H8 microprocessor WAIT input signal can be controlled externally by programming the FLASHPWD pin to switch to the WAIT input function. Setting the flag *FLASHPWD Disable* in CC Control Register 77 to 1 and GPO11 Select to 0, transforms the FLASHPWD output pin into a WAIT input pin. External devices driving WAIT must drive high on reset and until the software has changed the FLASHPWD pin to the WAIT function.

**Automatic Booting**

To allow download of FLASH memory code into the final system, the AD6426 provides a small dedicated routine to transfer code through the Data Interface into the FLASH memory. This routine is activated by asserting the BOOTCODE pin.

**Power Control**

The AD6426 and Layer 1 software is optimized to minimize the mobile radio power consumption in all modes of operation. Two power control registers are dedicated for activating and deactivating functional modules:

Bit	POWER CONTROL INTERNAL CC Control Register 44
2	<i>Synthesizer Interface Power Enable</i>
1	<i>DSP Interface Power Enable</i>
0	<i>Encryption Power Enable</i>

Bit	POWER CONTROL EXTERNAL CC Control Register 45
5	<i>Output Clock Enable (will reset to 1)</i>
4	<i>General Purpose Power Control</i>
2	<i>DSP Power Control</i>
1	<i>Radio Power Control</i>

**INTERFACES**

The GSM Processor provides eleven external interfaces for dedicated purposes:

1. Memory Interface
2. EEPROM Interface
3. SIM Interface
4. Accessory Interface
5. Universal System Connector Interface
6. Keypad / Backlight / Display Interface
7. Battery ID Interface
8. Voiceband/Baseband Converter (EVBC) Interface
9. Radio Interface
10. Test Interface
11. Debug Interface

**Memory Interface**

The memory interface of the AD6426 serves two purposes. Primarily, it provides the data, address, and control lines for the external memories (RAM and ROM / FLASH Memory). Secondly, the data and address lines are used to interface with the display. The pins of the memory interface are listed in Table 5.

*Table 5. Memory Interface*

Name	I/O	Function
ADD20 : 0	O	Address bus
DATA15:0	I/O	Data bus
RD	O	Read strobe
HWR	O	High write strobe / Upper Byte Strobe
LWR	O	Low write strobe / Lower Byte Strobe
WR	O	Write Strobe
RAMCS	O	RAM chip select
ROMCS	O	FLASH / ROM chip select
FLASHPWD	O	FLASH Powerdown

The HWR and LWR pins can be configured to function as UBS and LBS, respectively, by setting the SRAM16 bit (bit 0) of the MEMIF H8 Peripheral Control Register 80. This bit is reset at power-up. When configured as UBS and LBS, these pins facilitate access of 16-bit SRAM in conjunction with the Read/Write Strobes.

The pin FLASHPWD is automatically asserted low when the H8 enters the Software Standby Mode, and de-asserted when an interrupt causes the H8 to exit the Software Standby Mode. This allows the use of “deep power down mode” for certain FLASH memories. Also the entire data bus is driven low during software standby mode.

**EEPROM Interface**

The AD6426 provides a 3-wire interface to an external EEPROM by using three GPIOs of the control processor. Table 6 shows the functionality of these three pins.

*Table 6. EEPROM Interface*

Name	I/O	Function
EEPROMDATA	I/O	EEPROM data
EEPROMCLK	O	EEPROM clock
EEPROMEN	O	EEPROM enable

This Information applies to a product under development. Its characteristics and specifications are subject to change without notice. Analog Devices assumes no obligation regarding future manufacture unless otherwise agreed to in writing. No responsibility is assumed by Analog Devices for its use; nor for any infringements of patents or other rights of third parties which may result from its use. No license is granted by implication or otherwise under any patent or patent rights of Analog Devices.



The EEPROM interface is controlled entirely through software via the EEPROM register. This allows support for every desired timing and protocol.

Bit	EEPROM CC Control Register 8
4	<i>EEPROM Data Output Enable</i> when set to 1, the content of bit 0 will be written to the pin.
2	<i>EEPROM Clock</i> Connected to the EEPROMCLK pin
1	<i>EEPROM Enable</i> Connected to the EEPROMENABLE pin
0	<i>EEPROM Data</i> Connected to the EEPROMDATA pin

**SIM Interface**

The AD6426 allows direct interfacing to the SIM card via a dedicated SIM interface. This interface consists of 7 pins as shown in Table 7. Some applications may not require SIMPROG and SIMCARD; thus SIMPROG and SIMCARD can be re-used as additional general purpose I/O-pins.

Table 7. SIM Interface

Name	I/O	Function
SIMCARD	I	SIM card detect
SIMDATAOP	O	SIM data output
SIMDATAIP	I	SIM data input
SIMCLK	O	SIM clock
SIMRESET	O	SIM reset
SIMPROG	O	SIM program enable
SIMSUPPLY	O	SIM supply enable

**Accessory Interface**

The AD6426 provides 12 interface pins listed in Table 8 for control of peripheral devices such as a car kit. However, two general purpose I/O-pins of the Accessory Interface are proposed to be used for additional control of the radio section as described in the Radio Interface chapter.

Table 8. Accessory Interface

Name	I/O	Function
GPIO9:0	I/O	General purpose inputs/outputs
GPCS	O	General purpose chip select

All GPIO pins start up as inputs. GPIO8 and GPIO9 are controlled by flags in CC Control Register 79. When the *GPIO<sub>n</sub> OP Enable* flag is set to 0, the *GPIO<sub>n</sub> Data* flag

reflects the input pin state when read and writing to *GPIO<sub>n</sub> Data* has no effect.

When the *GPIO<sub>n</sub> OP Enable* flag is set to 1, the *GPIO<sub>n</sub> Data* flag returns when read the last value written to it and controls the GPIO<sub>n</sub> pin when written to it.

Additional general purpose inputs and outputs are available under software control. The following pins shown in Table 9 become general purpose inputs/outputs or outputs.

Table 9. Additional GPIO / GPO Pins

Pin Name	I/O	New Function
SIMCARD	I/O	GPIO16
SIMPROG	I/O	GPIO15
ADD20	O	GPO10
FLASHPWD	O	GPO11
TXPA	O	GPO12
CALIBRATERADIO	O	GPO13
TXENABLE	O	GPO14
SYNTHEN1	O	GPO17
AGCA	O	GPO18
AGCB	O	GPO19
USCRI	O	GPO20
USCRTS	O	GPO21
USCCTS	I	GPI22

If the pins SIMCARD and SIMPROG are not required in the application, they can be used as additional H8 programmable general purpose inputs or outputs.

Setting *GPO10 Select* (CC Control Register 7) to 1, will transform the pin ADD20 into a general purpose output allowing the pin to be directly controlled via *GPO10 Data*.

By setting *GPO11 Select* (CC Control Register 77) to 1 and *FLASHPWD Disable* to 1, the pin FLASHPWD becomes a general purpose output. The pin state is toggled by setting the *GPO11 Data* flag.

To increase the flexibility of the AD6426, three pins in the Radio Interface are multiplexed within GPO functions. The pins multiplexed are: SYNTHEN1, AGCA and AGCB, with the default function being the Radio Interface. The mode of these pins is controlled by the Channel Codec Register ccGPO.

The GPO[n]Sel bit selects the function of the pin. Setting GPO[n]Sel to one will enable the pin to be controlled by the GPO[n] bit. The GPO[n]Sel bit will override any other pin function selection.

This Information applies to a product under development. Its characteristics and specifications are subject to change without notice. Analog Devices assumes no obligation regarding future manufacture unless otherwise agreed to in writing. No responsibility is assumed by Analog Devices for its use; nor for any infringements of patents or other rights of third parties which may result from its use. No license is granted by implication or otherwise under any patent or patent rights of Analog Devices.

To transform the TXPA pin into a general purpose output, set TXPA Width = 0 (CC Control Register 75 and 76), then use TxPA Polarity flag (CC Control Register 6) to toggle pin state.

To use the CALBRATERADIO pin as a general purpose output, set the AUTOCALIBRATE flag to zero and use the CALBRATERADIO flag to toggle pin state.

### Universal System Connector Interface

A typical GSM handset requires multiple serial connections to provide data during normal phone operation, manufacturing, testing, and debug. In an ideal case many of these functions could be combined into a single multi-purpose system connector. For example, the USC port can be used for:

- Flash code download for manufacturing and updates
- Booting - UART interface used to download programs to H8 memory
- DAI Acoustic mode testing - connects System Simulator (SS) directly to EVBC
- DAI Transcoding mode - connects SS to 6426 for speech codec testing
- External DTA (Data Terminal Adapter) - asynchronous link for MSDI interface
- RS232 port - for on-board data services
- H8 debug / monitor
- Hands-free operation - time shared VBC and H8 port
- Receive I/Q monitoring

The Universal System Connector (USC) of the 6426 is designed such that no external glue logic is required to achieve this multi-purpose functionality. Furthermore, since the USC's function is related to the voiceband and I/Q data serial ports, the USC block is also responsible for the correct configuration of these serial data streams.

The actual system connector has the minimum number of pins to achieve the needed functionality. This save system pins, and allows for a more reliable connector from a manufacturing and mechanical standpoint. The USC defines a 5 pin connector that multiplexes asynchronous, synchronous, and modem control signals as needed:

Name	I/O	Function
USCRX	I	Receive Data
USCTX	O	Transmit Data
USCRTS	O	Ready to Send
USCCTS	I/O	Clear to Send / Transmit Frame Sync
USCRI	I/O	Ring Indicator / Serial Clock

### Operating modes of the USC

#### Buffered UART Mode (Booting/Data Services)

This mode attaches the H8/DSP buffered UART to the USC, bringing out either the serial bit rate clock or the Modem Control Signal RI. This is the default mode when the phone is powered up.

The BOOTCODE pin will be latched on RESET high. If BOOTCODE is high at RESET, execution begins from the Boot ROM which will configure the buffered UART to download the FLASH programming code into RAM. The FLASH program itself is also downloaded via the UART.

An external Data Terminal Adapter can also be used. In this case Data Services are done external to the phone and then transferred to and from the H8. With the external Data Terminal Adapter, the serial bit rate clock output is selected for USCRI pin.

This mode can be used for a variety of H8 debug tasks as the UART can be used to simply shift debug information out.

Note that when in this mode if the handshake signals and serial bit clock are not required, the RTS and RI pins can be used as extra GPO, and the CTS pin used as an extra GPI.

#### Time-shared Mode (Multi-switch)

This mode allows time multiplexed communication with both the H8 and DSP. This is most useful as a hands-free solution, but can be used for other purposes also e.g., DAI Transcoding Testing. This mode is used for DAI testing of the DSP's speech transcoder in which the DSP's SPORT0 is connected to the USC through the Multi-switch.

#### DAI Acoustic Mode Testing

This mode is used for DAI testing of the 6425's phone's acoustic properties. The VSPORT of the 6425 connects to the USC through the Multi-switch.

#### IQ Monitoring

This mode is used for testing the RF receive path and allows access to the I and Q samples from the AD6425. The AD6425 signals are simply routed to the USC. This means that the clock and frame sync are provided by the 6425 as well.

#### 16 bit Mode

This mode connects the synchronous data path to the SDIR/SDOR H8 Peripheral Control Registers, giving the H8 full access to the synchronous port bandwidth. This allows a fast synchronous communication to an external device, and is intended to be used for a fast download mechanism.

This Information applies to a product under development. Its characteristics and specifications are subject to change without notice. Analog Devices assumes no obligation regarding future manufacture unless otherwise agreed to in writing. No responsibility is assumed by Analog Devices for its use; nor for any infringements of patents or other rights of third parties which may result from its use. No license is granted by implication or otherwise under any patent or patent rights of Analog Devices.

**Keypad / Backlight / Display Interface**

This interface combines all functions of display and keyboard as shown in Table 10.

Table 10. Keypad / Backlight / Display Interface

Name	I/O	Function
KEYPADROW5 : 0	I	Keypad row inputs
KEYPADCOL3 : 0	O	Keypad column strobes
BACKLIGHT	O	Backlight control
DISPLAYCS	O	Display Controller chip select
LCDCTL	O	LCD Control / Serial Display Data Output
GPIO3	O	Serial Display Data Output
GPIO4	O	Serial Display Clock Output

By providing 4 keypad-column outputs (open drain, pull low) and 6 keypad-row inputs the AD6426 can monitor up to 24 keys. Additionally, an extra column can be implemented by using the “ghost column” method for a total of 30 keys. The H8 processor is interrupted whenever a key is pressed. The KEYPADCOL pins are connected to the *Keypad Column3-0* flags in the KEYPAD COLUMN CC Control Register 9.

Bit	KEYPAD COLUMN CC Control Register 9
3 : 0	<i>Keypad Column 3-0</i>

The six KEYPADROW pins are connected to the *Keypad Row 5-0* flags in the KEYPADROW CC Control Register 10.

Bit	KEYPADROW CC Control Register 10
5 : 0	<i>Keypad Row 5-0</i>

One backlight control output (BACKLIGHT) is provided, which can be modulated to provide the same perceived brightness for a reduced average current. Switching frequency as well as duty cycle can be modified to compensate for ambient lighting levels and changing battery voltage.

The BACKLIGHT output is activated by setting the *Backlight1* flag in the SYSTEM CC Control Register 0.

Bit	SYSTEM CC Control Register 0
5	<i>Backlight 1</i>

Once activated, an internal PWM circuit can control the frequency and the duty cycle of the output signal. The PWM circuit is enabled by the *Modulate1* flag in the BACKLIGHT CC Control Register 50. To switch the backlight continuously on, enable the *Backlight 1* flag and disable the *Modulate 1* flag.

Bit	BACKLIGHT CC Control Register 50
2	<i>Modulate 1</i>
1: 0	<i>Backlight LED Control (1:0)</i>

The frequency is determined by the flags *Backlight LED Control (1:0)* in the same register as shown in Table 11.

Table 11. Backlight Frequency

Bit 1	Bit 0	Frequency
0	0	6.3475 kHz
0	1	12.695 kHz
1	0	25.390 kHz
1	1	50.780 kHz

Duty cycle can be selected between 0 and 124/128 in 32 steps of 4/128 by programming the *Backlight Duty Cycle (4:0)* flags in the POWER CONTROL INTERNAL CC Control Register 44.

Bit	POWER CONTROL INTERNAL CC Control Register 44
7 : 3	<i>Backlight Duty Cycle (4:0)</i>

The active period is determined according to the formula:

$$\text{Active (high) Period} = \frac{\text{Backlight Duty Cycle (4:0)} \times 4}{128}$$

The 6426 offers both parallel and serial interfaces for connecting to LCD display controllers.

The parallel interface to a LCD controller is provided by two dedicated control signals (LCDCTL and DISPLAYCS) and parts of the address and data bus. A typical interface is shown in Figure 5.

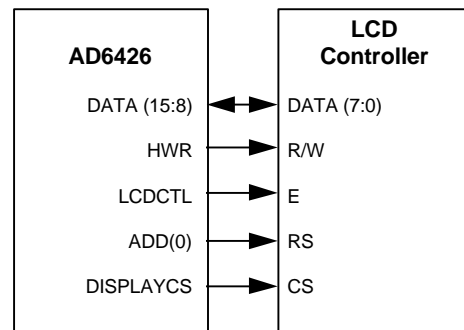

Figure 5. Parallel Display Interface

The on-chip control circuit automatically generates wait states for interfacing to external display devices.

This Information applies to a product under development. Its characteristics and specifications are subject to change without notice. Analog Devices assumes no obligation regarding future manufacture unless otherwise agreed to in writing. No responsibility is assumed by Analog Devices for its use; nor for any infringements of patents or other rights of third parties which may result from its use. No license is granted by implication or otherwise under any patent or patent rights of Analog Devices.

**Serial Display Interface**

The serial display interface is compatible with display drivers by Motorola and Seiko-Epson. The display driver by Motorola uses an SPI serial bus which requires an inverted or delayed clock in comparison to the Seiko-Epson type display driver.

In the Motorola mode the data is delayed by one half clock cycle such that the data is driven on the rising edge of SCLK instead of on the falling edge.

The serial display interface consists of four pins; a serial data output (DISPD0), clock (DISPCLK), chip enable (DISPEN) and address (DISPA0). These pins are multiplexed with GPIO4, GPIO3, LCDCTL and DISPLAYCS.

Bit 1 (DISP) of the MEMIF H8 Peripheral Control Register 80 controls the configuration of the display interface. With this set to 0, the parallel display interface is used. Setting this bit to one enables the use of the serial display interface. This bit is set to 0 on reset.

Bit 4 (SERDISP MODE) of the SERDISPLAY/NMI H8 Peripheral Control Register 106 controls the serial display mode. The default setting is Seiko-Epson mode. To enable the Motorola mode the user must set the register bit to ONE.

**Display Reset**

No dedicated pin is used to reset the display sub system. It is recommended that the VBCRESET pin is used for this function by connecting the Reset input on the display and the Reset input on the VBC to the AD6426 VBCRESET pin. The VBC and display cannot be reset independently. However one of the GPIO pins can be used to reset the display separately.

**Battery ID Interface**

The AD6426 provides a single-wire interface compatible with the Dallas Semiconductor™ DS2434 or DS2435 Battery Identification chip. The communication protocol supports three operations: RESET, READ and WRITE. These operations permit reading the present status off the battery and writing updated information to the ID chip. The interface is available as the BATID function multiplexed on the GPIO5 pin.

Bit 3 (DALLAS EN) of the MEMIF H8 Peripheral Control Register 80 controls the enabling of the battery ID interface module. Setting this bit to zero enables the interface, resetting the bit disables it. This bit is set to one on reset.

**EVBC Interface**

The AD6426 interfaces directly to the Enhanced Voiceband Baseband Converter AD6425 through the pins shown in Table 12. The communication is performed through three serial ports: the Auxiliary Serial Port (ASPORT), the Baseband Serial Port (BSPORT) and the Voiceband Serial Port (VSPORT). Layer 1 software enables/disables the clock output in order to reduce system power consumption to a minimum if operation of the AD6425 is not required. Figure 6 shows the interface between the AD6426 and the AD6425 as well as to the AD6432 IF chip.

Table 12. EVBC Interface

Name	I/O	Function
CLKOUT	O	Clock Output to EVBC
EVBCRESET	O	Reset Output to EVBC
ASPORT		
ASDO	O	Data Output
ASOFS	O	Output Framing Signal
ASCLK	O	Clock Output
ASDI	I	Data Input
BSPORT		
BSDO	O	Data Output
BSOFS	O	Output Framing Signal
BSCLK	I	Clock Input
BSIFS	I	Input Framing Signal
BSDI	I	Data Input
VSPORT		
VSDO	O	Data Output
VSDI	I	Data Input
VSCLK	I	Clock Input
VSFS	I	Input/Output Framing Signal

This Information applies to a product under development. Its characteristics and specifications are subject to change without notice. Analog Devices assumes no obligation regarding future manufacture unless otherwise agreed to in writing. No responsibility is assumed by Analog Devices for its use; nor for any infringements of patents or other rights of third parties which may result from its use. No license is granted by implication or otherwise under any patent or patent rights of Analog Devices.

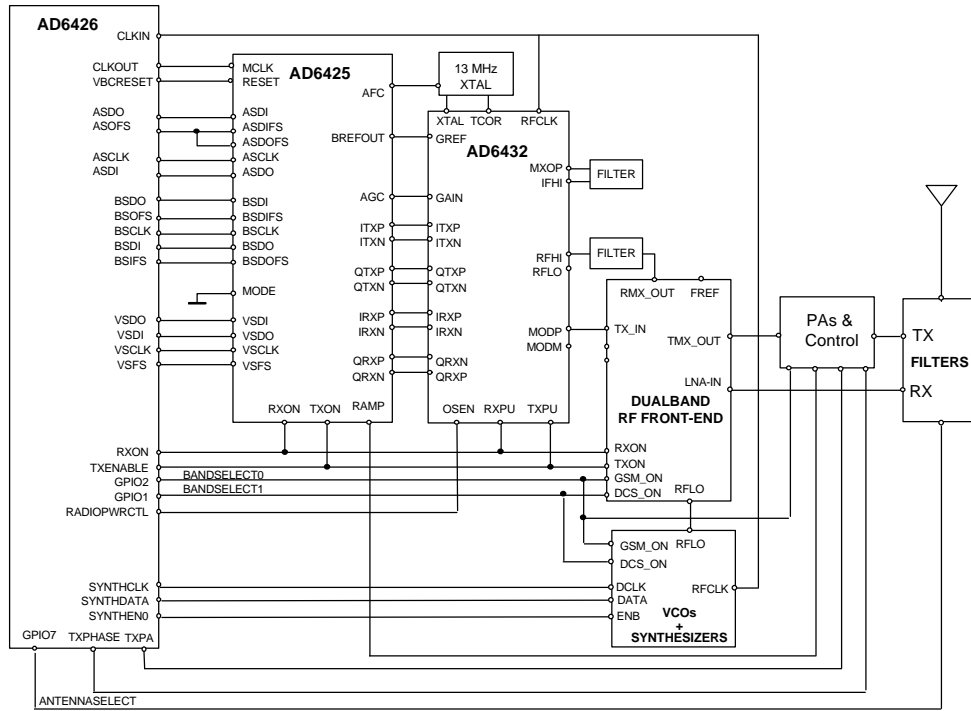

Figure 6. EVBC and Radio Interface

This Information applies to a product under development. Its characteristics and specifications are subject to change without notice. Analog Devices assumes no obligation regarding future manufacture unless otherwise agreed to in writing. No responsibility is assumed by Analog Devices for its use; nor for any infringements of patents or other rights of third parties which may result from its use. No license is granted by implication or otherwise under any patent or patent rights of Analog Devices.

**Radio Interface**

The AD6426 Radio Interface has been designed to support direct connection to the ADI IF-Chips AD6432, while providing full backwards compatibility to existing radio designs interfacing to the AD20msp410 and AD20msp415. Additionally the AD6426 Radio Interface supports radio architectures based on Siemens, TTP/Hitachi or Philips RF chipsets.

The Radio Interface of the AD6426 consists of 16 dedicated output pins listed in Table 13. Together with two optional general purpose I/O-pins they provide a flexible interface to a variety of radio architectures for both 900 MHz and 1800/1900 MHz operation.

**Dual Band Control**

To support dual band handsets BANDSELECT[1:0] signals are provided. BANDSELECT0 is multiplexed with GPIO[2], with the default function of this being GPIO[2]. BANDSELECT1 is multiplexed with GPIO[1], the default function being GPIO[1].

For Dual Band solutions requiring a single band select bit, the BANDSELECT0 function is enabled by asserting the BAND EN bit. In order to set BANDSELECT0 high/low and cause the radio module to operate in the appropriate band, the least significant bit (bit 0) of the relevant 32 bit register for Dynamic Synthesizer 1 must be written, i.e. different values may be set for Rx, Tx and Monitor but only for Dynamic Synthesizer 1.

BANDSELECT0 is sampled internally and is valid from the beginning of data serialization, both for on demand (immediate) loading and ordinary interrupt driven loading. The BANDSELECT0 signal will remain in this known state until the next time there is any serialization of data for Dynamic Synthesizer 1, when a new sample will be taken of the least significant bit of the 32 bit synthesizer register currently being serialized.

Full control is provided over the number of bits to be shifted out to the synthesizer and so it is intended that this bit count will always be less than 32 when using the BANDSELECT0 feature in order to prevent shifting the control bit out. BANDSELECT0 is gated with RADIO POWER CONTROL to ensure that whenever the RADIO is off, BANDSELECT0 is forced to a low state.

For Dual Band Solution requiring two band select bits, one for GSM900, and one for DCS1800, then both BANDSELECT0 and BANDSELECT1 are enabled by asserting both the BAND EN and DCSEL EN bits. The BANDSELECT0 output is driven as in the single enable mode (described above), and the BANDSELECT1 output is the inverted output of the raw BANDSELECT0 output (prior to gating with RADIO POWER

CONTROL), gated with RADIO POWER CONTROL to force a low output when the Radio is off.

In order to increase the flexibility of the AD6426, three pins in the Radio Interface are multiplexed with GPO functions. The pins multiplexed are: SYTHEN1, AGCA and AGCB, with the default function being the Radio Interface.

The mode of these pins is controlled by the new ccGPO Channel Codec Register:

The GPO[n]Sel bit selects the function of the pin. Setting GPO[n]Sel to one will enable the pin to be controlled by the GPO[n] bit. The GPO[n]Sel bit will override any other pin function selection.

**Generic Pins**

The following three pins have the same functionality in all types of radio architectures:

**RADIOPWRCTL**

This output signal is typically used to power down the oscillators and prescalers during Idle mode and is directly controlled by the *Radio Power Control* flag in the POWER CONTROL EXTERNAL CC Control Register 45.

Bit	POWER CONTROL EXTERNAL CC Control Register 45
1	<i>Radio Power Control</i>

Table 13. Radio Interface

Name	I/O	Function
GPIO1	O	BANDSELECT1
GPIO2	O	BANDSELECT0
RADIOPWRCTL	O	Radio Powerdown Control
GPIO6	O	VBIAS
GPIO7	O	ANTENNASELECT
TXPHASE	O	Switches PLLs (Rx / Tx)
TXENABLE	O	Transmit Enable
TXPA	O	Power Amplifier Enable
RXON	O	Receiver on
CALIBRATERADIO	O	Radio Calibration
SYNTHEN0	O	Synthesizer 0 Enable
SYNTHEN1	O	Synthesizer 1 Enable
SYNTHDATA	O	Synthesizer Port Serial Data
SYNTHCLK	O	Synthesizer Port Clock
AGCA	O	AGC Control A
AGCB	O	AGC Control B

This Information applies to a product under development. Its characteristics and specifications are subject to change without notice. Analog Devices assumes no obligation regarding future manufacture unless otherwise agreed to in writing. No responsibility is assumed by Analog Devices for its use; nor for any infringements of patents or other rights of third parties which may result from its use. No license is granted by implication or otherwise under any patent or patent rights of Analog Devices.

**GPIO6 - VBIAS**

This general purpose I/O pin can be used to control the powering up/down of a separate voltage converter, which may be needed to provide the supply voltage for GaAs RF Power Amplifiers. Significant turn-on time of the voltage converter requires an early power-up signal, which is provided by GPIO6. This control is achieved entirely through a software driver, without hardware support. Since this function is not needed for all radio solutions, the GPIO pin can be used for other functions if not required.

**GPIO7 - ANTENNASELECT**

This general purpose I/O pin can be used to switch between two different antennas, as required, when the mobile radio is used in conjunction with a car-kit with external antenna. This control is achieved entirely through a software driver, without hardware support. Since this function is not needed for all radio solutions, the GPIO pin can be used for other functions if not required.

**Tx Timing Control**

The following 5 radio interface pins serve different functions depending on the radio architecture:

**TXPHASE**

The purpose of this signal is to switch PLLs between Rx and Tx modes. The signal is generated under control of the flags *TXPHASE Enable* and *TXPHASE Polarity* of the RADIO CONTROL CC Control Register 2.

Bit	RADIO CONTROL CC Control Register 2
6	<i>TXPHASE Polarity</i> Controls the polarity of the output TXPHASE. When set to 1, TXPHASE is active low; When set to 0, TXPHASE is active high.
3	<i>TXPHASE Enable</i> Enables the output pin TXPHASE if set to 1.
0	<i>Transmit Enable</i> Enables the output pin TXENABLE if set to 1.

In radios based on the TTP/Hitachi solution, this signal can be used to switch the VCO's.

In radios based on the Siemens or Philips solution, this signal can be used for control switching PLLs, or band switching UHF PLLs.

**TXENABLE**

This signal enables the RF modulator and transmit chain including the PA, and controls the TXON-pin of the AD6426. The signal is generated under control of flag *Transmit Enable* of the RADIO CONTROL CC Control Register 2.

**TXPA**

This signal is used as a power amplifier (PA) enable and/or as a control signal for the PA control loop. This allows the PA to be isolated from the supply outside the Tx-slot to save current. In the PA control loop it can be used to control the dynamics of the loop. The flag *Tx Pa Polarity* in the TRAFFIC MODE CC Control Register 6, provides independent control for the TXPA signal.

Bit	TRAFFIC MODE CC Control Register 6
7	<i>Tx Pa Polarity</i> ; active high, when reset

TXPA is derived from the leading edge of TXENABLE signal shown in Figure 7.

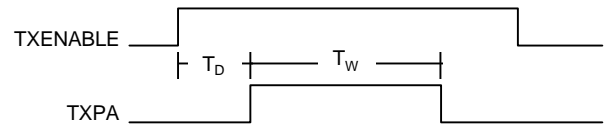

Figure 7. Timing of TXPA

The parameter  $T_D$  is a programmable delay (0 to 1023  $Q_{BIT}$ ) to accommodate the EVBC settling time.  $T_D$  is therefore a 10 bit value, accessed via the TXPA OFFSET 1 CC Control Register 73 and the TXPA OFFSET 2 CC Control Register 74.

Bit	TXPA OFFSET 1 CC Control Register 73
1 : 0	$T_D$ (9:8)

Bit	TXPA OFFSET 2 CC Control Register 74
7 : 0	$T_D$ (7:0)

The parameter  $T_W$  is a programmable width (0 to 1023  $Q_{BIT}$ ) which defines the PA enable time.  $T_W$  is therefore a 10 bit value, accessed via the TXPA WIDTH 1 CC Control Register 75 and the TXPA WIDTH 2 CC Control Register 76.

Bit	TXPA WIDTH 1 CC Control Register 75
1 : 0	$T_W$ (9:8)

Bit	TXPA WIDTH 2 CC Control Register 76
7 : 0	$T_W$ (7:0)

If  $T_W$  is set to zero, then TXPA will be disabled.

This Information applies to a product under development. Its characteristics and specifications are subject to change without notice. Analog Devices assumes no obligation regarding future manufacture unless otherwise agreed to in writing. No responsibility is assumed by Analog Devices for its use; nor for any infringements of patents or other rights of third parties which may result from its use. No license is granted by implication or otherwise under any patent or patent rights of Analog Devices.

**Rx Timing Control**

**RXON**

The signal at the output pin RXON is generated by the function *Receive Enable OR Monitor Enable* of the RADIO CONTROL CC Control Register 2. It can be used to enable the RF receiver and controls the RXON-pin of the AD6425. In radios based on the Siemens solution this signal would be connected to the RXON1 input. Additional RXON derived signals are provided to support this solution.

Bit	RADIO CONTROL CC Control Register 2
2	<i>Monitor Enable</i>
1	<i>Receive Enable</i>

**CALIBRATERADIO**

The 4 modes of the Autocalibrate signal (Type 0 & 1, AutoCal on/off) are provided as required by the ADI or Philips solution and shown in Figure 8.

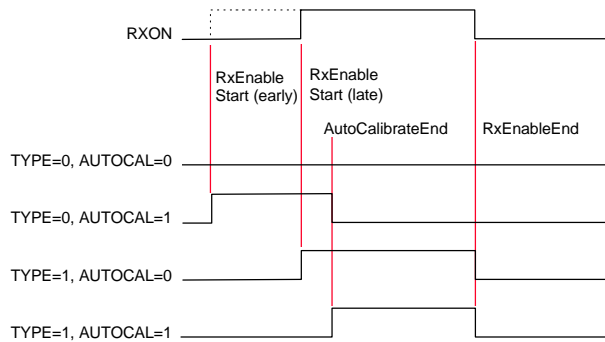

Figure 8. Autocalibration

The flags *Autocalibrate* and *Calibrate Radio* in the SYSTEM CC Control Register 0 are OR'ed and connected to the output pin CALIBRATERADIO.

Bit	the SYSTEM CC Control Register 0
7	<i>Autocalibrate</i> Enables the autocalibrate function if set to 1;
3	<i>Calibrate Radio</i>

The type of autocalibration is set in the TRAFFIC MODE CC Control Register 6

Bit	TRAFFIC MODE CC Control Register 6
3	<i>Autocalibration Type</i>

In radios based on the Siemens chipset, this signal would connect to the RXON2 input. The required behavior is enabled by selecting the Type 1 CalibrateRadio function.

**Synthesizer Control**

The radio interface of the AD6426 supports 2 dynamic synthesizers, with each capable of downloading data on demand.

The two *Synthesizer Load Dynamic* flags located in the SYNTH CONTROL CC Control Register 38, will set the synthesizer interface to load 3 consecutive long-words from Layer 1.

Bit	SYNTH CONTROL CC Control Register 38
7	<i>Synthesizer Enable Polarity</i> Selects the polarity of the SYNTHEN outputs. If set to 0, SYNTHEN is an active low signal, if set to 1, SYNTHEN is an active high signal.
6	<i>Synthesizer Enable Type</i> Selects the active period of the SYNTHEN outputs. When set to 0, SYNTHEN is active for all data values determined by SYNTHESIZER BIT COUNT; when set to 1, SYNTHEN goes active after the last bit for one SYNTHCLK period.
2	<i>Synthesizer Load Dynamic 1 (SLD1)</i>
1	<i>Synthesizer Load Dynamic 0 (SLD0)</i>

When using the *Configure Dynamic Synthesizer* flag in the SYNTH BIT COUNT CC Control Register 37, the download-on-demand function is applied to the synthesizer selected by *SLD0* or *SLD1*.

Bit	SYNTH BIT COUNT CC Control Register 37,
6	<i>Configure Dynamic Synthesizer</i>

Each dynamic synthesizer is comprised of three 32-bit word registers, for the Rx, Tx and Monitor phases. The download on demand uses the Rx register only for the respective synthesizer.

Bit	SYNTHESIZER 1 CC Control Register 40
7 : 0	Synthesizer (31:24)

Bit	SYNTHESIZER 2 CC Control Register 41
7 : 0	Synthesizer (23:16)

Bit	SYNTHESIZER 3 CC Control Register 42
7 : 0	Synthesizer (15:8)

Bit	SYNTHESIZER 4 CC Control Register 43
7 : 0	Synthesizer (7:0)

This Information applies to a product under development. Its characteristics and specifications are subject to change without notice. Analog Devices assumes no obligation regarding future manufacture unless otherwise agreed to in writing. No responsibility is assumed by Analog Devices for its use; nor for any infringements of patents or other rights of third parties which may result from its use. No license is granted by implication or otherwise under any patent or patent rights of Analog Devices.



The two dynamic synthesizers are programmable as follows, while each synthesizer may be independently disabled, through the two *Disable Synthesizer* flags in the SYNTHESIZER PROGRAM CC Control Register 72.

Bit	SYNTHESIZER PROGRAM CC Control Register 72
5	<i>Disable Synthesizer 1</i>
4	<i>Disable Synthesizer 0</i>
3	<i>Synthesizer Enable Select</i>
2	<i>Synthesizer Mode</i>
1 : 0	<i>Pin Mode (1:0)</i>

**SYNTHEN0 : 1**

The AD6426 provides enable signals for two independent synthesizers. These signals are available at the output pins SYNTHEN0 and SYNTHEN1. The polarities of these signals are individually programmable; i.e. bit 7 of CC Control Register 38 is applied to the synthesizer selected by either bit 2 or bit 1 of the same register.

**SYNTHDATA and SYNTHCLK**

Three Modes can be selected to support different radio architectures. The selection of the Pin-Mode is done by the two *Pin Mode* flags in the SYNTHESIZER PROGRAM CC Control Register 72 as shown in Table 14.

Table 14. Pin Mode

Bit 1	Bit 0	Mode
0	0	Mode 1 (default)
0	1	Mode 1
1	0	Mode 2
1	1	Mode 3

The default is Mode 1, which supports TTP/Hitachi Bright and Philips radio architectures. Mode 2 also supports a Philips architecture, while Mode 3 supports a Siemens architecture. In Mode 1, the pins SYNTHDATA and SYNTHCLK have their original functionality; i.e. SYNTHDATA is the data output and SYNTHCLK is the clock output of the serial synthesizer interface. Clock polarity and frequency are programmed in the SYNTH CONTROL CC Control Register 38.

Table 15. Pin Function in Mode 1

AD6426 Pin	Function
SYNTHDATA	Synthesizer Data
SYNTHCLK	Synthesizer Clock

Bit	SYNTH CONTROL CC Control Register 38
5	<i>Synthesizer Clock Polarity</i> Selects the edge, on which synthesizer data and enable will be clocked out. Negative edge, when set to 0; positive edge, when set to 1.
0	<i>Synthesizer Clock;</i> selects the frequency of SYNTHCLK output. SYNTHCLK = 1.625 MHz if set to 0 (default), SYNTHCLK = 6.5 MHz if set to 1.

In Modes 2 and 3, the outputs of these two pins are multiplexed with flags of the internal DSP as indicated in Table 16. The function of DSPFLAG1 ⇕ Synthesizer Data is defined as: The output is that of DSPFLAG1 except when the synthesizer interface is active. In this case the synthesizer output has priority. The same applies to DSPFLAG2 ⇕ Synthesizer Clock.

Table 16. Pin Function in Modes 2 and 3

AD6426 Pin	Function
SYNTHDATA	DSPFLAG1 ⇕ Synthesizer Data
SYNTHCLK	DSPFLAG2 ⇕ Synthesizer Clock

**AGC Control**

AGC programming is achieved in one of three ways:

The first is a gain select approach, whereby the DSPFLAG0 and DSPFLAG1 are used as a 2-bit gain selector (AGCA, AGCB). This is available in Mode 1 and the flags are under direct control of the internal DSP and are timing independent of the synthesizer interface.

Table 17. Pin Function in Mode 1

AD6426 Pin	Function
AGCA	DSPFLAG0
AGCB	DSPFLAG1

The second is through the DSP combined with the serial synthesizer interface, as defined in Mode 2. The function of DSPFLAG0 ⇕ SYNTHEN1 is defined as: The output is that of DSPFLAG0 except when the synthesizer interface is active.

To support the Philips chipset whereby the AGC and the PLL are programmed over the same enable line, the AGCA pin is multiplexed to provide a SYNTHEN1 gated with DSPFLAG0. This pin would be wired instead of the SYNTHEN1 pin. Since the DSP would program the AGC during RXON, and the synthesizers are reprogrammed following the end of the active phase, no conflict can occur.

This Information applies to a product under development. Its characteristics and specifications are subject to change without notice. Analog Devices assumes no obligation regarding future manufacture unless otherwise agreed to in writing. No responsibility is assumed by Analog Devices for its use; nor for any infringements of patents or other rights of third parties which may result from its use. No license is granted by implication or otherwise under any patent or patent rights of Analog Devices.

In Modes 2 and 3, PLL programming occurs on any of Rx, Tx and MonEnableEnd through the synthesizer interface. Additionally, AGC programming, controlled via the DSP, is performed during RXON.

Table 18. Pin Function in Mode 2

AD6426 Pin	Function
AGCA	DSPFLAG0 ⇕ SYNTHEN1
AGCB	DSPFLAG1

The third mode is for support of the Siemens chipset, providing an independent AGC enable from SYNTHEN using the DSP Flag 0. The same serial interface constraints from Mode 2 apply. Additionally, the output OCE is provided. This is the Offset Correction Enable, derived from the RxEnableStartEarly and RxEnableStartLate timing signals as shown in Figure 9.

Table 19. Pin Function in Mode 3

AD6426 Pin	Function
AGCA	DSPFLAG0
AGCB	OCE

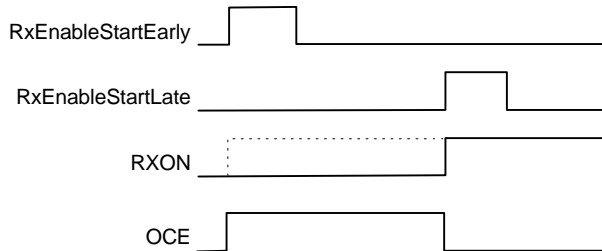

Figure 9. OCE Signal

This Information applies to a product under development. Its characteristics and specifications are subject to change without notice. Analog Devices assumes no obligation regarding future manufacture unless otherwise agreed to in writing. No responsibility is assumed by Analog Devices for its use; nor for any infringements of patents or other rights of third parties which may result from its use. No license is granted by implication or otherwise under any patent or patent rights of Analog Devices.

**TEST INTERFACE**

The AD6426 provides a complete JTAG test interface. The functionality of these pins are shown in Table 20. Furthermore, these pins can assume a different functionality described in detail in the chapter MODES OF OPERATION.

Table 20. Test Interface

Name	I/O	Function
JTAGEN	I	JTAG enable (internal pull down resistor)
TCK	I	JTAG test clock input
TMS	I	JTAG test mode select
TDI	I	JTAG test data input
TDO	O	JTAG test data output

**JTAG Port**

The AD6426 provides full IEEE 1149.1 compliance. The JTAG Port must be run at a frequency of 5 MHz or less.

The JTAG Port is explicitly enabled through JTAGEN. When disabled, the corresponding pins are re-used for the AD6426 Feature Modes. The JTAG interface implements four registers shown in Figure 10. The content of the Instruction register selects one of these four registers.

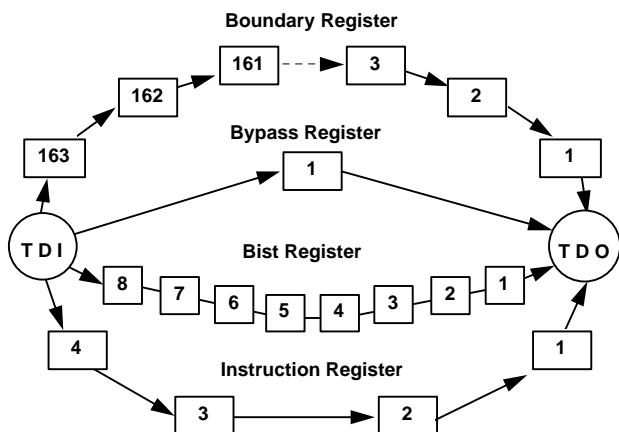

Figure 10. JTAG Registers

The instruction register contains 4 bits, and supports the instructions listed in Table 21.

Instruction register values 01XX all select the bypass register when JTAG compliance is enabled. Values 00XX control the AD6426 I/O as defined in Mode A, and therefore should not be used in any other mode.

Table 21. JTAG Instructions

Instr. Register	Code	Comments
4 3 2 1		
0 0 0 0	ExTest	Public Instruction
0 0 0 1	Clamp	Optional Public Instruction
0 0 1 0	Sample/PreLoad	Public Instruction
0 0 1 1	DoBist	Private Instruction Engineering Mode Test
0 1 0 0 - 0 1 0 1		Reserved
0 1 1 0	Mode D	Private Instruction H8 Emulation
0 1 1 1		Reserved
1 0 0 0 - 1 1 1 0	Bypass	Public Instruction Selects Mode A
1 1 1 1	Bypass	Public Instruction Selects Mode A (default)

**ExTest Instruction**

The ExTest instruction is used to force input or output conditions on the boundary scan cell.

**Clamp Instruction**

This optional public instruction is similar to the Bypass instruction, except that once loaded, it will force the values held in the boundary scan chain onto the corresponding outputs of the device. This enables all output and bi-directional pads to be fixed, allowing other parts on the PC-board to be tested without interference from the AD6426, while at the same time selecting the Bypass register for the shortest possible scan path.

All input activity to the AD6426 will be ignored during this time, since all inputs are driven from the preloaded values in the boundary scan chain. Typically therefore this instruction would be preceded by the Sample/Preload instruction. This instruction is only valid during the normal operation of the AD6426; i.e. in Mode A.

**Sample/Preload Instruction**

The Sample/Preload instruction is fully IEEE compliant.

**Boundary Register**

The boundary cell structure is based on the I/O definition in Mode A, and hence pins which are outputs only in this mode, but become inputs in another mode, do not support input scan cells, and vice versa. Table 22 shows the complete Boundary register.

This Information applies to a product under development. Its characteristics and specifications are subject to change without notice. Analog Devices assumes no obligation regarding future manufacture unless otherwise agreed to in writing. No responsibility is assumed by Analog Devices for its use; nor for any infringements of patents or other rights of third parties which may result from its use. No license is granted by implication or otherwise under any patent or patent rights of Analog Devices.



**DoBist Instruction**

This instruction is provided to support engineering mode test. When the instruction is loaded, it will generate an NMI to the H8 processor. This will enable special software to be executed which can be used to test the operation of the device. During this time, the 8-bit DoBist register is selected for scan, enabling a result code for the test to be scanned out. For the duration of the test, all I/O retain their normal function. The test program must therefore cope with undefined inputs, but is able to communicate with other devices to extend the test procedure. This allows the NMI to be generated during normal phone operation. This instruction is only valid during the normal operation of the AD6426; i.e. in Mode A.

**Mode D Instruction**

This instruction switches the AD6426 into the H8 Emulation Mode (Mode D). It is only valid to switch modes while the AD6426 is held in reset.

**Reset**

To comply with the IEEE specification, the JTAG interface will be forced to reset whenever the JTAG Port is re-enabled. This will select the Bypass register and force the AD6426 into the Normal Mode (Mode A).

**Debug Port Interface**

In normal (voice-service) operation, the Universal Serial Port can be used as a monitor port, which allows monitoring internal operation of the channel codec section. However, during the use of GSM Data Services, the USC is engaged in data communication and cannot be used for monitoring. The 6426 provides a Debug Port to enable monitoring and debugging in this case. This is in the form of a simple 2 pin UART. The communication format is fixed at 9600 baud, 8 data bits, one stop bit, no parity, asynchronous communication. Operation of the Debug Port is under control of the Layer 1 software.

Two of the GPIO pins can be programmed to be used as the Debug Port:

Pin Name	New Function
GPIO8	TXDATA
GPIO9	RXDATA

The serial port can be enabled by asserting the flag *DATA SERIAL PORT SELECT* in CC Control Register 7.

**MODES OF OPERATION**

The AD6426 can be switched between two main operating modes, using instructions downloaded via the JTAG interface. This must be done while the AD6426 is held in reset. Once the instruction load is completed the pins are immediately set to reflect the new operating mode. Table 23 shows these modes. The modes B and C are reserved and are not available to the user.

Table 23. Modes of Operation

	Mode of Operation
A	Normal Mode
B	Reserved
C	Reserved
D	Emulation Mode (H8)

**Normal Mode (Mode A)**

This mode is used during normal operation of the AD6426. All JTAG-pins have their normal functionality, when enabled by JTAGEN and can be used for production test.

**Emulation Mode (Mode D)**

Selecting Mode D allows the emulation of the internal H8 processor. In this Mode several pins assume a new functionality or are no longer available. Table 24 lists all pins, which have different functionality or direction in the Emulation Mode compared to the Normal Mode.

In Emulation Mode the internal DSP remains active but will not have access to external memory devices. The internal H8 will be switched into hardware stand-by mode; the LCD controller interface and Boot Code ROM remain functional.

CCIRQ0 : 2 are channel codec interrupts to the emulator. CCIRQ2 is defined in CC Control Registers 77 and 78.

Table 24. Pin Functions in Mode D

Pin Name in Normal Mode (A)	Pin Function in Emulation Mode (D)	
IRQ6	CCCS	I
ADD19 : 16	-	TRI
ADD15 : 0	ADD15 : 0	I
DATA7 : 0	-	TRI
RD	RD	I
HWR	HWR	I
LWR	-	TRI
RAMCS	-	TRI
SIMCARD	-	TRI
SIMDATAOP	-	TRI - O
SIMDATAIP	-	I
SIMCLK	-	O
SIMRESET	CCIRQ0	O
SIMPROG	CCIRQ2	O
SIMSUPPLY	CCIRQ1	O
GPIO9	H8CS0	I
GPIO8	CCGPIO8	I/O - TRI

This Information applies to a product under development. Its characteristics and specifications are subject to change without notice. Analog Devices assumes no obligation regarding future manufacture unless otherwise agreed to in writing. No responsibility is assumed by Analog Devices for its use; nor for any infringements of patents or other rights of third parties which may result from its use. No license is granted by implication or otherwise under any patent or patent rights of Analog Devices.

Pin Name in Normal Mode (A)	Pin Function in Emulation Mode (D)	
GPO10	WAIT	O
GPCS	-	TRI
FLASHPWD	Forced High	O
DISPLAYCS	DISPLAYCS	I/O
GPIO0	Reserved	O
GPIO1	Forced High/ BANDSELECT1	O
GPIO2	Forced High/ BANDSELECT0	O
GPIO3	Forced High/DISPA0	O
GPIO4	Forced High/DISPCLK	O
GPIO5	Forced High/BATID	O
GPIO6	Reserved	O
GPIO7	Reserved	TRI

FLASHPWD can also be used as WAIT input, in which case it is routed through and gated with the LCDWAIT to be output on the WAIT output pin GPO10/ADD20. If the on-chip LCD controller is not used in emulation, then ADD20 pin can be used as ccGPO(10).

**FEATURE MODES**

Two additional features can be enabled under software control.

These are; DAI Mode (Digital Audio Interface) and HSL Mode (High Speed Logging) used to monitor the operation of the on-chip DSP.

**DAI Mode**

This mode is selected during type approval, when Digital Audio Interface is required. To enable this feature, the JTAGEN pin must be de-asserted, upon which the JTAG pins TMS, TDI and TDO are re-assigned as shown in Table 25. The default feature mode thus enabled is DAI. In addition, the voiceband serial port signals are made available through the USC to facilitate testing of the speech transcoder as well as the phone’s acoustic properties. The DAI box interface product is available upon request from Analog Devices.

Table 25. DAI Mode

AD6426 Pin	Function in DAI Mode	I/O
VSCLK	MSCLK	I
VSFS	MSFS	I
VSDO	MSRXD	O
VSDI	MSTXD	I
TMS	DAIRESET	O
TDI	DAI1	O
TDO	DAI0	I

This Information applies to a product under development. Its characteristics and specifications are subject to change without notice. Analog Devices assumes no obligation regarding future manufacture unless otherwise agreed to in writing. No responsibility is assumed by Analog Devices for its use; nor for any infringements of patents or other rights of third parties which may result from its use. No license is granted by implication or otherwise under any patent or patent rights of Analog Devices.

**High Speed Logging**

This mode is selected for monitoring the operation of the internal DSP during the development and field test phase. When the JTAGEN pin is de-asserted and the *HSLEnable* flag in the TESTADDRESS CC Control Register 33 is set, a high speed logging port is mapped on the JTAG- and EEPROM pins as shown in Table 26. The internal DSP must then be instructed via Layer 1 to output logging messages onto the HSL pins.

Table 26. HSL Mode

AD6426 Pin	Function in HSL Mode	
TCK	HSLDO0	O
TMS	HSLDO1	O
TDO	HSLDO2	O
TDI	HSLDO3	O
EEPROMCLK	HSLCLK	O
EERPROMEN	HSLFS	O

The High Speed Logging port (HSL) is an unidirectional port which supplies nibble-wide synchronous data from the internal DSP to an external data logger. The data logger will be connected to a PC which will be responsible for presenting the data to the user. The PC is able to configure the HSL via either one of the serial interfaces.

The HSL is enabled as follows:

- The JTAGEN pin is set to 0
- The H8 enables the HSL logic by setting the *HSLEnable* flag
- On a command issued through the Data Interface, the H8 configures the DSP software to enable HSL

The *HSLEnable* flag is used to deselect DAIRESET in favor of the HSL onto the JTAG pins, and enable the HSL onto EEPROMCLK and EEPROMEN.

The DSP sends data over the port by writing to address 0x000 in the Data Memory map. The writes are full 16-bit writes, and can occur at a maximum rate of one write per five 39 MHz clock cycles. Five cycles allow time for the HSL circuit to serialize the 16 bits of data onto the 4-bit data bus with one cycle to spare. HSLFS is used to frame the valid data nibbles. Note that HSCLK is free-running , and that HSLFS and HSLDO3-0 are synchronized to the rising edge of HSCLK.

The mapping of the DSP data bits to the HSL port bits is:

Table 27. Mapping of HSL Port Nibbles

DSP Data Bits	HSLDO Nibble
23 : 20	1
19 : 16	2
15 : 12	3
11 : 8	4

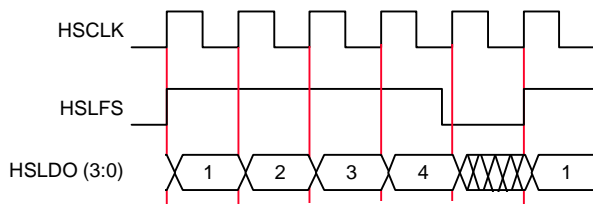

Figure 11. HSL Timing

This Information applies to a product under development. Its characteristics and specifications are subject to change without notice. Analog Devices assumes no obligation regarding future manufacture unless otherwise agreed to in writing. No responsibility is assumed by Analog Devices for its use; nor for any infringements of patents or other rights of third parties which may result from its use. No license is granted by implication or otherwise under any patent or patent rights of Analog Devices.

SPECIFICATIONS

General

Parameter	Min	Typ	Max	Units	Comments
T <sub>A</sub> , Ambient Operating Temperature	-25		+85	°C	
V <sub>DD</sub> , Supply Voltage	2.4		3.3	Volt	
I <sub>DD</sub> , Supply Current (Idle Mode)		TBD		mA	@ V <sub>DD</sub> = 3.0 V
I <sub>DD</sub> , Supply Current (Talk Mode)		TBD		mA	@ V <sub>DD</sub> = 3.0 V
f <sub>CLKIN</sub> , Clock Input Frequency		13		MHz	
V <sub>CLKIN</sub> , Clock Input Voltage	0.250			V <sub>PP</sub>	sine wave, ac-coupled
R <sub>CLKIN</sub> , Clock Input Resistance (see Note)		19.5		kΩ	sine wave, ac-coupled
<b>Logic Inputs</b>					
V <sub>IH</sub> , Input High Voltage	V <sub>DD</sub> - 0.8			Volt	
V <sub>IL</sub> , Input Low Voltage			0.8	Volt	
I <sub>IH</sub> , I <sub>IL</sub> Input Current	-10		10	μA	
C <sub>IN</sub> , Input Capacitance		TBD		pF	
<b>Logic Outputs</b>					
V <sub>OH</sub> , Output High Voltage	V <sub>DD</sub> - 0.4				
V <sub>OL</sub> , Output Low Voltage			0.4		
I <sub>OZL</sub> , Low Level Output 3-State Leakage Current	-10		10	μA	
I <sub>OZH</sub> , High Level Output 3-State Leakage Current	-10		10	μA	

**Note:**

The input impedance of the clock buffer is a function of the voltage and waveform of the clock input signal. For sinusoidal input signals the typical input impedance can be calculated by: R<sub>IN</sub> [kΩ] = V<sub>CLKIN</sub> [V<sub>PP</sub>] × 78

**ABSOLUTE MAXIMUM RATINGS**

VDD to GND ..... -0.3V to + TBD V  
 Digital I/O Voltage to GND ..... -0.3V to VDD + 0.3V  
 Operating Temperature Range ..... -25°C to +85°C

**LQFP Package**

Storage Temperature Range ..... -65°C to +150°C  
 Maximum Junction Temperature ..... +150°C  
 Q<sub>JA</sub> Thermal Impedance ..... 28°C/W  
 Lead temperature, Soldering  
     Vapor Phase (60 sec) ..... +215°C  
     Infrared (15 sec) ..... +220°C

**PBGA Package**

Storage Temperature Range ..... -65°C to +150°C  
 Maximum Junction Temperature ..... +150°C  
 Q<sub>JA</sub> Thermal Impedance ..... 30°C/W  
 Lead temperature, Soldering  
     Vapor Phase (60 sec) ..... +215°C  
     Infrared (15 sec) ..... +220°C

**Note:**

Stresses above those listed under “Absolute Maximum Ratings” may cause permanent damage to the device. This is a stress rating only and functional operation of the device at these or any other conditions above those listed in the operational sections is not implied. Exposure to absolute maximum rating conditions for extended periods may affect device reliability. T<sub>A</sub>= +25°C unless otherwise stated.

**ESD SUSCEPTIBILITY**

ESD (electrostatic discharge) sensitive device. Electrostatic charges as high as 4000 volts, which readily accumulate on the human body and on test equipment, can discharge without detection. Although this device features proprietary ESD protection circuitry, permanent damage may still occur on this device if it is subjected to high energy electrostatic discharges. Therefore, proper precautions are recommended to avoid any performance degradation or loss of functionality.



This Information applies to a product under development. Its characteristics and specifications are subject to change without notice. Analog Devices assumes no obligation regarding future manufacture unless otherwise agreed to in writing. No responsibility is assumed by Analog Devices for its use; nor for any infringements of patents or other rights of third parties which may result from its use. No license is granted by implication or otherwise under any patent or patent rights of Analog Devices.



# TIMING CHARACTERISTICS

Clocks

Parameter	Comment	Min	Typ	Max	Units
$t_1$	CLKIN Period (see Figure 13)		76.9		ns
$t_2$	CLKIN Width Low	30		45	ns
$t_3$	CLKIN Width High	30		45	ns
$t_4$	CLKOUT Period (see Figure 14)		76.9		ns
$t_5$	CLKOUT Width Low	30		45	ns
$t_6$	CLKOUT Width High	30		45	ns

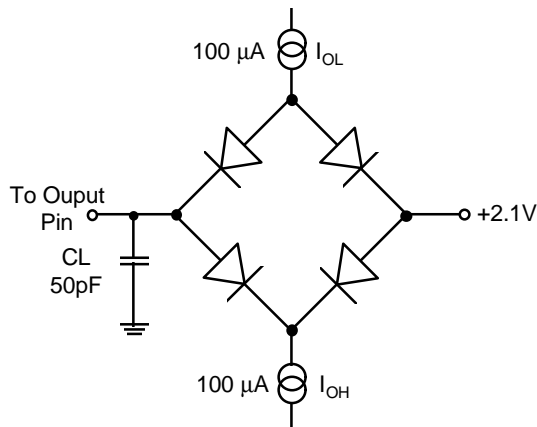

Figure 12. Load Circuit for Timing Specifications

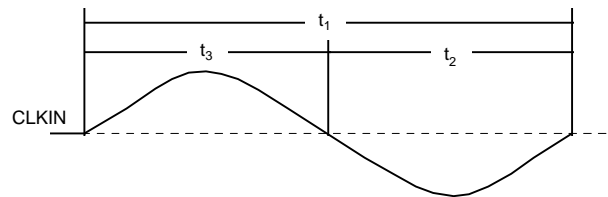

Figure 13. Clock Input

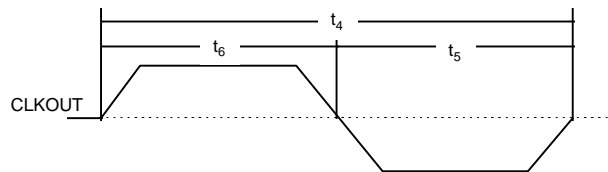

Figure 14. Clock Output

This Information applies to a product under development. Its characteristics and specifications are subject to change without notice. Analog Devices assumes no obligation regarding future manufacture unless otherwise agreed to in writing. No responsibility is assumed by Analog Devices for its use; nor for any infringements of patents or other rights of third parties which may result from its use. No license is granted by implication or otherwise under any patent or patent rights of Analog Devices.

TIMING SPECIFICATION

Memory Interface

Parameter	Comment ( Timing for 3-state access, see Figure 15 )	Min	Max	Units
<b>Timing Requirement</b>				
t <sub>10b</sub>	Control Processor read chip select to data valid		158	ns
t <sub>12b</sub>	Control Processor read address to data valid		162	ns
t <sub>17</sub>	Control Processor read enable to data valid		129	ns
t <sub>19</sub>	Control Processor data hold	0		ns
<b>Switching Characteristic</b>				
t <sub>10a</sub>	Control Processor write chip select setup	10		ns
t <sub>11</sub>	Control Processor chip select hold	5		ns
t <sub>12a</sub>	Control Processor write address setup	10		ns
t <sub>13</sub>	Control Processor address hold	5		ns
t <sub>14</sub>	Control Processor write pulse width	111		ns
t <sub>15</sub>	Control Processor data setup	68		ns
t <sub>16</sub>	Control Processor data hold	15		ns
t <sub>18</sub>	Control Processor read pulse width	145		ns

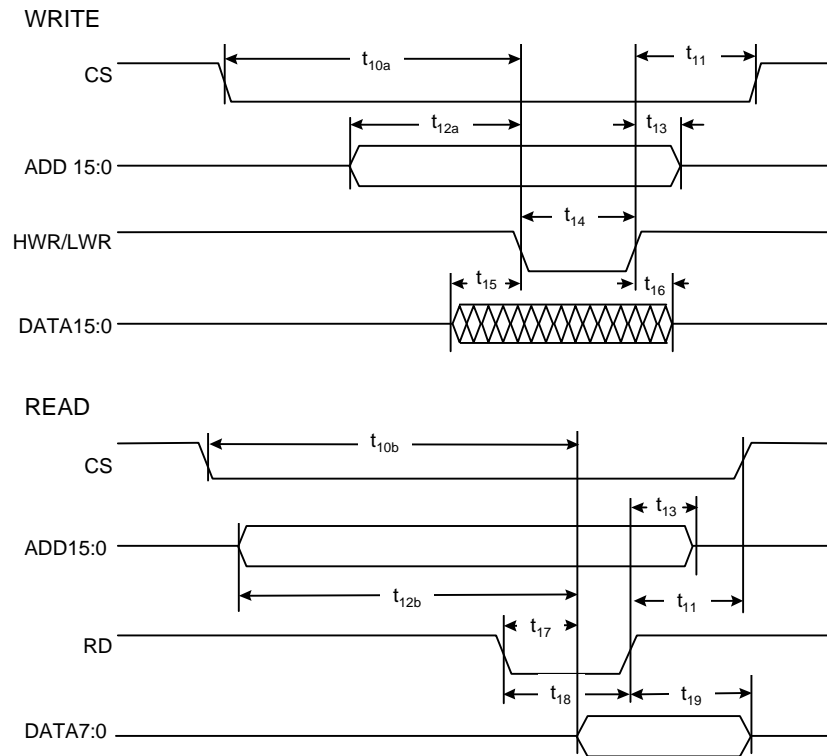

Figure 15. Memory Interface Timing

This Information applies to a product under development. Its characteristics and specifications are subject to change without notice. Analog Devices assumes no obligation regarding future manufacture unless otherwise agreed to in writing. No responsibility is assumed by Analog Devices for its use; nor for any infringements of patents or other rights of third parties which may result from its use. No license is granted by implication or otherwise under any patent or patent rights of Analog Devices.

TIMING CHARACTERISTICS

Radio Interface

Parameter	Comment ( see Figure 16 )	Min	Max	Units
t <sub>40</sub>	Synthesizer clock period	152	615	ns
t <sub>41</sub>	Synthesizer clock high	76	307	ns
t <sub>42a</sub>	Synthesizer data setup	60	85	ns
t <sub>42b</sub>	Synthesizer data hold	60	85	ns
t <sub>43a</sub>	Synthesizer enable delay for Type 0	60	85	ns
t <sub>43b</sub>	Synthesizer enable delay for Type 1	-15	10	ns
t <sub>44</sub>	Synthesizer enable width for Type 1	50	90	ns

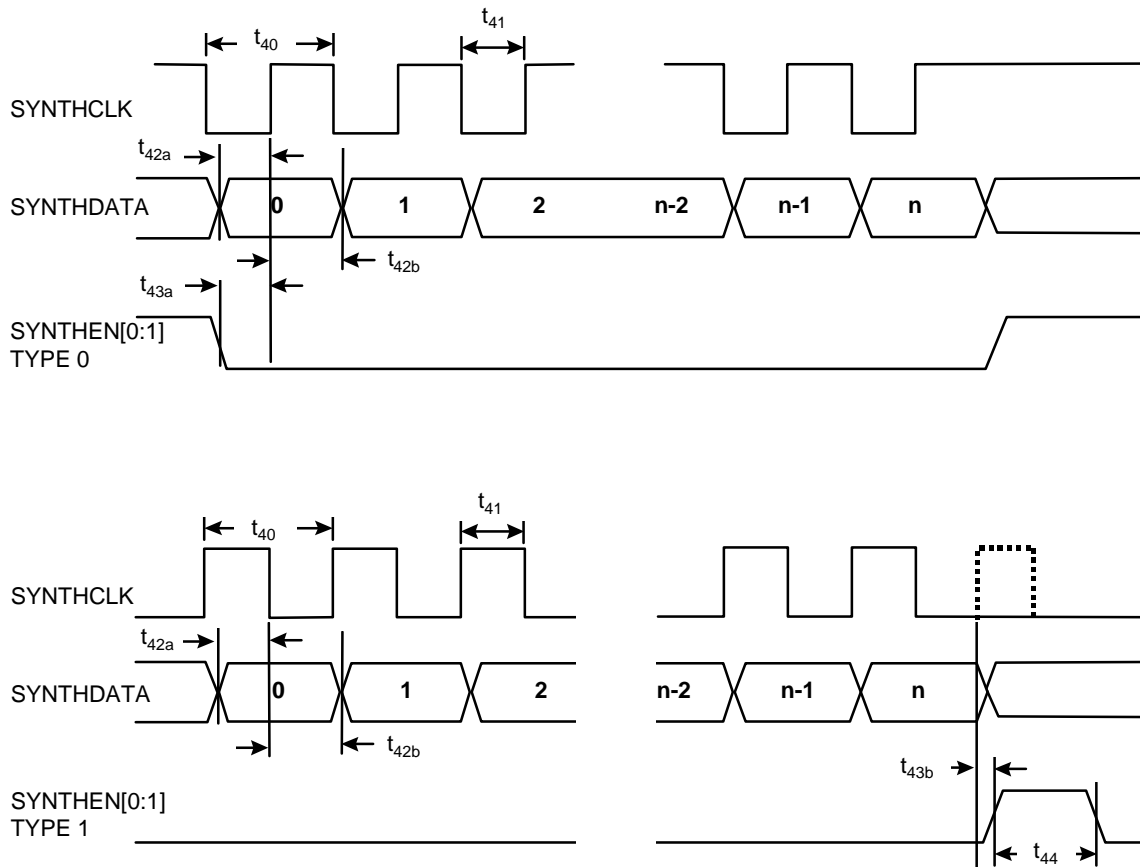

Figure 16. Synthesizer Interface Timing

This Information applies to a product under development. Its characteristics and specifications are subject to change without notice. Analog Devices assumes no obligation regarding future manufacture unless otherwise agreed to in writing. No responsibility is assumed by Analog Devices for its use; nor for any infringements of patents or other rights of third parties which may result from its use. No license is granted by implication or otherwise under any patent or patent rights of Analog Devices.

# TIMING CHARACTERISTICS

## High Speed Logging Interface

Parameter	Comment ( see Figure 17)	Min	Typ	Max	Units
t <sub>50</sub>	HSCLK Period		25.6		ns
t <sub>51</sub>	HSCLK Width Low	8.3			ns
t <sub>52</sub>	HSCLK Width High	8.3			ns
t <sub>53</sub>	HSCLK to HSLDO	0		15	ns
t <sub>54</sub>	HSCLK to HSLFS	0		15	ns

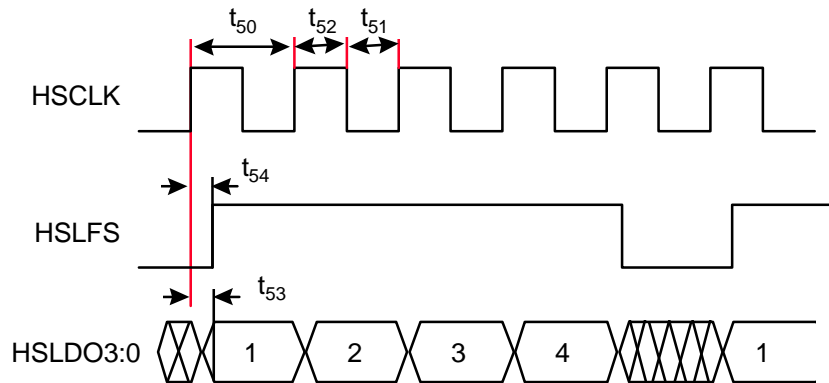

Figure 17. High Speed Logging Interface

This Information applies to a product under development. Its characteristics and specifications are subject to change without notice. Analog Devices assumes no obligation regarding future manufacture unless otherwise agreed to in writing. No responsibility is assumed by Analog Devices for its use; nor for any infringements of patents or other rights of third parties which may result from its use. No license is granted by implication or otherwise under any patent or patent rights of Analog Devices.

# TIMING CHARACTERISTICS

Data Interface

Parameter	Data Interface (see Figure 18)	Min	Typ	Max	Units
$t_{60}$	Clock Period				ns
$t_{61}$	Transmit Data Delay time			100	ns
$t_{62}$	Receive Data Setup time	100			ns
$t_{63}$	Receive Data Hold time	0			ns

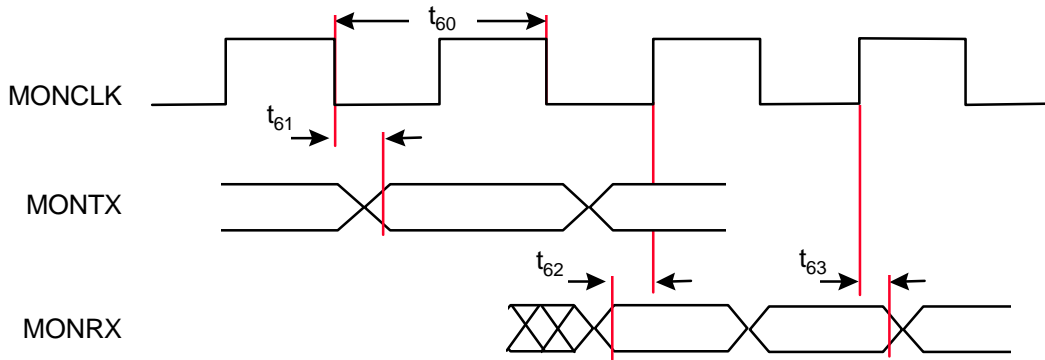

Figure 18: Data Interface Timing

This Information applies to a product under development. Its characteristics and specifications are subject to change without notice. Analog Devices assumes no obligation regarding future manufacture unless otherwise agreed to in writing. No responsibility is assumed by Analog Devices for its use; nor for any infringements of patents or other rights of third parties which may result from its use. No license is granted by implication or otherwise under any patent or patent rights of Analog Devices.

# TIMING CHARACTERISTICS

Test Interface

Parameter	JTAG Port	Min	Typ	Max	Units
t <sub>64</sub>	TCK Period*	200			ns
t <sub>65</sub>	TCK Width Low*	80		120	ns
t <sub>66</sub>	TCK Width High*	80		120	ns

\* Note: These parameters have been functionally verified, but not tested.

This Information applies to a product under development. Its characteristics and specifications are subject to change without notice. Analog Devices assumes no obligation regarding future manufacture unless otherwise agreed to in writing. No responsibility is assumed by Analog Devices for its use; nor for any infringements of patents or other rights of third parties which may result from its use. No license is granted by implication or otherwise under any patent or patent rights of Analog Devices.

# TIMING CHARACTERISTICS

## EVBC Interface ASPORT

Parameter	Comment (see Figure 19)	Min	Typ	Max	Units
$t_{70}$	ASCLK period		384		ns
$t_{71}$	ASOFS setup time before ASCLK high	20			ns
$t_{72}$	ASOFS hold time after ASCLK high	20			ns
$t_{73}$	ASDI setup time before clock low	20			ns
$t_{74}$	ASDI hold time after clock low	20			ns
$t_{75}$	ASDO delay after clock high	0		20	ns

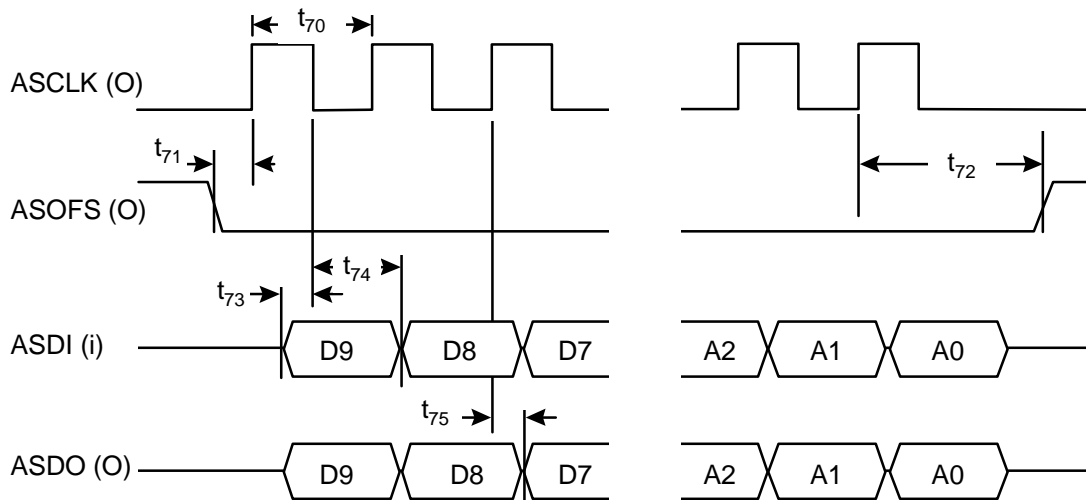

Figure 19. EVBC Interface ASPORT Timing

This Information applies to a product under development. Its characteristics and specifications are subject to change without notice. Analog Devices assumes no obligation regarding future manufacture unless otherwise agreed to in writing. No responsibility is assumed by Analog Devices for its use; nor for any infringements of patents or other rights of third parties which may result from its use. No license is granted by implication or otherwise under any patent or patent rights of Analog Devices.

# TIMING CHARACTERISTICS

## EVBC Interface BSPORT

Parameter	Comment (see Figure 20)	Min	Typ	Max	Units
t <sub>80</sub>	BSCLK period	76.9			ns
t <sub>81</sub>	BSIFS setup time before BSCLK low	4			ns
t <sub>82</sub>	BSIFS hold time after BSCLK low	7			ns
t <sub>83</sub>	BSDI setup time before BSCLK low	4			ns
t <sub>84</sub>	BSDI hold time after BSCLK low	7			ns
t <sub>85</sub>	BSOFS delay after BSCLK high			15	ns
t <sub>86</sub>	BSDO delay after BSCLK high	0		15	ns

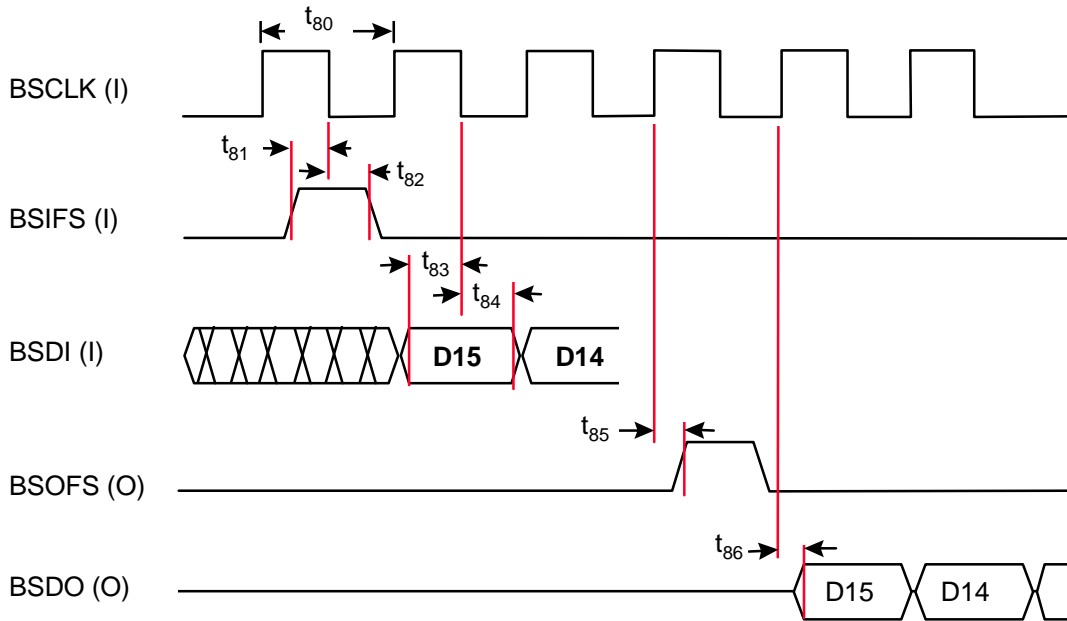

Figure 20. EVBC Interface BSPORT Timing

This Information applies to a product under development. Its characteristics and specifications are subject to change without notice. Analog Devices assumes no obligation regarding future manufacture unless otherwise agreed to in writing. No responsibility is assumed by Analog Devices for its use; nor for any infringements of patents or other rights of third parties which may result from its use. No license is granted by implication or otherwise under any patent or patent rights of Analog Devices.



# TIMING CHARACTERISTICS

## EVBC Interface VSPORT

Parameter	Comment (see Figure 21)	Min	Typ	Max	Units
$t_{90}$	VSCLK period	76.9			ns
$t_{91}$	VSFS setup time before VSCLK low	4			ns
$t_{92}$	VSFS hold time after VSCLK low	7			ns
$t_{93}$	VSDI setup time before VSCLK low	4			ns
$t_{94}$	VSDI hold time after VSCLK low	7			ns
$t_{95}$	VSDO delay after VSCLK high	0		15	ns

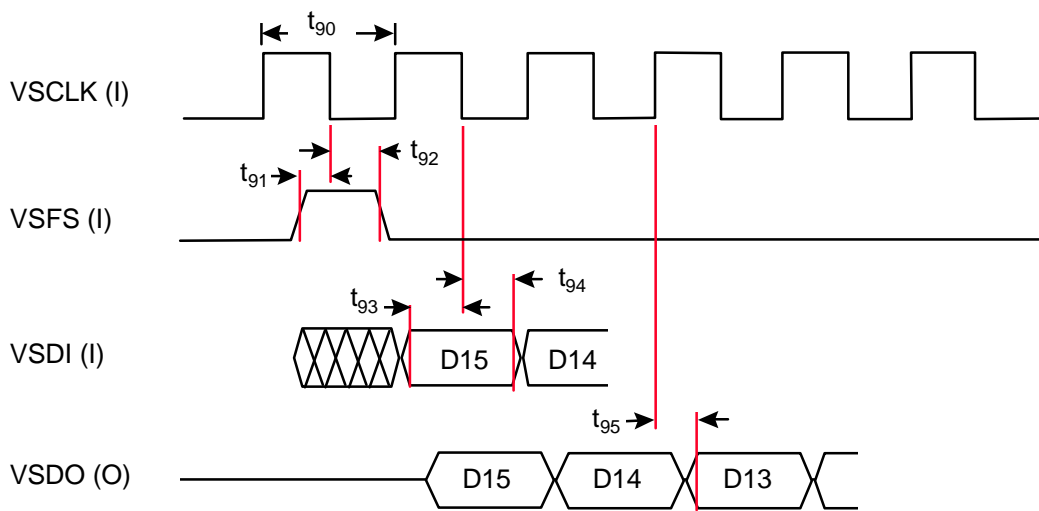

Figure 21. EVBC Interface VSPORT Timing

This Information applies to a product under development. Its characteristics and specifications are subject to change without notice. Analog Devices assumes no obligation regarding future manufacture unless otherwise agreed to in writing. No responsibility is assumed by Analog Devices for its use; nor for any infringements of patents or other rights of third parties which may result from its use. No license is granted by implication or otherwise under any patent or patent rights of Analog Devices.

# TIMING CHARACTERISTICS

## Parallel Display Interface

Parameter	Comments (see Figure 22)	Min	Typ	Max	Units
t <sub>100</sub>	LCD Control low width (6 CLKIN cycles)	462			ns
t <sub>101</sub>	LCD Control high width (6 CLKIN cycles)	462			ns
t <sub>102</sub>	LCD Control high width read extension (1 CLKIN cycle)	77			ns

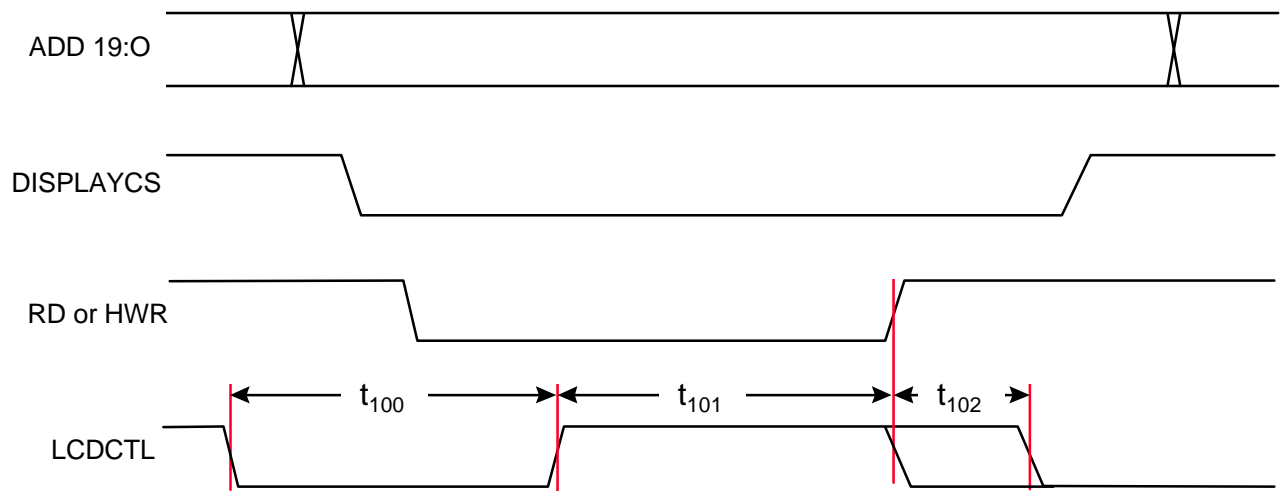

Figure 22. Parallel Display Interface Timing

This Information applies to a product under development. Its characteristics and specifications are subject to change without notice. Analog Devices assumes no obligation regarding future manufacture unless otherwise agreed to in writing. No responsibility is assumed by Analog Devices for its use; nor for any infringements of patents or other rights of third parties which may result from its use. No license is granted by implication or otherwise under any patent or patent rights of Analog Devices.

# TIMING CHARACTERISTICS

## Serial Display Interface

Parameter	Comment (see Figure 23)	Min	Typ	Max	Units
t <sub>103</sub>	DISP_CLK Period		t <sub>1</sub> *8 or t <sub>1</sub> *16		ns
t <sub>104</sub>	DISP_CS Low to Data Valid		0.25 *t <sub>103</sub> + 5		ns
t <sub>105</sub>	DISP_CLK Low to Data Valid		5		ns
t <sub>106</sub>	DISP_CLK Low to DISP_CS high		0.25 *t <sub>103</sub>		ns
t <sub>107</sub>	Data Valid to DISP_CLK High		0.25 *t <sub>103</sub> - 5		ns

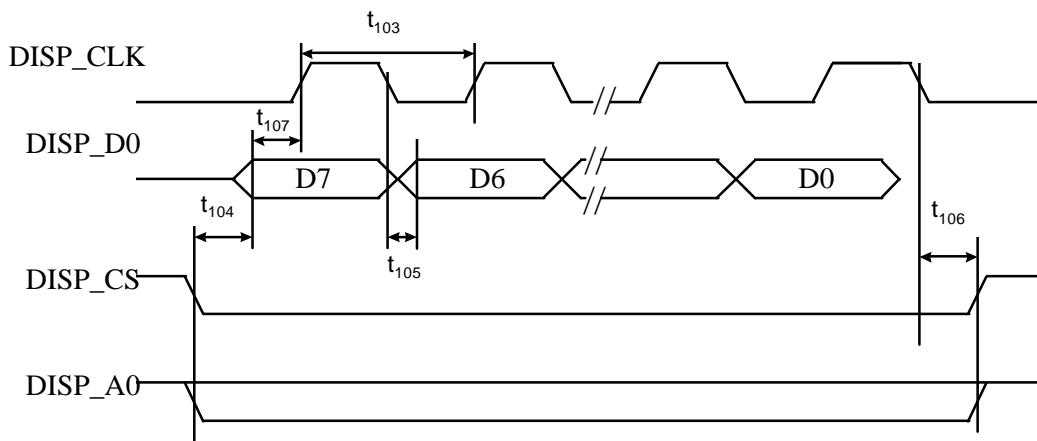

Figure 23. Serial Display Interface

This Information applies to a product under development. Its characteristics and specifications are subject to change without notice. Analog Devices assumes no obligation regarding future manufacture unless otherwise agreed to in writing. No responsibility is assumed by Analog Devices for its use; nor for any infringements of patents or other rights of third parties which may result from its use. No license is granted by implication or otherwise under any patent or patent rights of Analog Devices.

PACKAGING

LQFP Pin Locations

#	Pin Name	#	Pin Name	#	Pin Name	#	Pin Name
1	USCRI (MONCLK)	37	DATA12	73	TDI	109	AGCB
2	USCRX (MONRX)	38	DATA11	74	JTAGEN	110	TXPA
3	USCTX (MONTX)	39	DATA10	75	EEPROMEN	111	CALIBRATERADIO
4	USCCTS (ADD20)	40	DATA9	76	EEPROMCLK	112	RADIOPWRCTL
5	USCRTS (GPIO9)	41	DATA8	77	EEPROMDATA	113	TXENABLE
6	GPO10 (GPIO8)	42	RD	78	GND	114	GND
7	ADD19	43	GND	79	VDD	115	CLKIN
8	ADD18	44	VDD	80	VSDO	116	VDD
9	ADD17	45	UBS (HWR)	81	VSFS	117	GPIO7
10	ADD16	46	LBS (LWR)	82	VSDI	118	GPIO6
11	ADD15	47	DATA7	83	VSCLK	119	GPIO5
12	ADD14	48	DATA6	84	VBCRESET	120	GPIO4
13	ADD13	49	DATA5	85	RXON	121	GPIO3
14	ADD12	50	DATA4	86	CLKOUT	122	LCDCCTL
15	ADD11	51	DATA3	87	BSDO	123	DISPLAYCS
16	GND	52	DATA2	88	BSOFS	124	BACKLIGHT
17	VDD	53	DATA1	89	BSIFS	125	VDD
18	ADD10	54	DATA0	90	BSDI	126	GND
19	ADD9	55	GND	91	BSCLK	127	OSC13MON (GPPWRCTL)
20	BOOTCODE (GND)	56	VDD	92	ASCLK	128	GPCS
21	ADD8	57	FLASHPWD	93	ASDI	129	KEYPADCOL3
22	ADD7	58	WR (GPIO2)	94	ASOFS	130	KEYPADCOL2
23	ADD6	59	GND	95	ASDO	131	KEYPADCOL1
24	ADD5	60	VDD	96	TXPHASE	132	KEYPADCOL0
25	ADD4	61	GPIO1	97	GPIO2 (CPPWD)	133	GND
26	ADD3	62	GPIO0	98	VDD (GND)	134	KEYPADROW5
27	ADD2	63	SIMSUPPLY	99	GND (VDD)	135	KEYPADROW4
28	ADD1	64	SIMPROG	100	OSCIN (SAMCS)	136	KEYPADROW3
29	ADD0	65	SIMRESET	101	OSCOUT (CPFS)	137	KEYPADROW2
30	RAMCS	66	SIMDATAIP	102	VDDRTC (CPDO)	138	KEYPADROW1
31	GND	67	SIMDATAOP	103	PWRON (CPDI)	139	KEYPADROW0
32	VDD	68	SIMCLK	104	SYNTHEN1	140	VDD
33	ROMCS	69	SIMCARD	105	SYNTHEN0	141	RESET
34	DATA15	70	TCK	106	SYNTHDATA	142	IRQ6
35	DATA14	71	TMS	107	SYNTHCLK	143	GPIO8 (BOOTCODE)
36	DATA13	72	TDO	108	AGCA	144	GPIO9 (H8MODE)

Note: pin names in ( ) are the AD6422 pin names from the AD20msp415 chipset.

This Information applies to a product under development. Its characteristics and specifications are subject to change without notice. Analog Devices assumes no obligation regarding future manufacture unless otherwise agreed to in writing. No responsibility is assumed by Analog Devices for its use; nor for any infringements of patents or other rights of third parties which may result from its use. No license is granted by implication or otherwise under any patent or patent rights of Analog Devices.

PBGA Pin Locations

#	Pin Name	#	Pin Name	#	Pin Name	#	Pin Name
A1	USCR1	D1	ADD16	G1	BOOTCODE	K1	GND
A2	IRQ6	D2	ADD17	G2	ADD7	K2	ROMCS
A3	KEYPADROW0	D3	USCCTS	G3	ADD9	K3	DATA10
A4	KEYPADROW4	D4	GPIO8	G4	ADD4	K4	DATA9
A5	KEYPADCOL1	D5	VDD	G5	ADD1	K5	VDD
A6	GPCS	D6	GND	G6	ADD11	K6	DATA6
A7	VDD	D7	BACKLIGHT	G7	DATA3	K7	GND
A8	VDD	D8	GPIO5	G8	ASDI	K8	VDD
A9	CLKIN	D9	SYNTHCLK	G9	BSOFS	K9	SIMRESET
A10	GND	D10	PWRON	G10	VBCRESET	K10	EEPROMEN
A11	TXPA	D11	OSCOUT	G11	BSDI	K11	EEPROMDATA
A12	AGCB	D12	VDD	G12	BSIFS	K12	GND
B1	USCRX	E1	ADD13	H1	ADD6	L1	DATA15
B2	GPIO9	E2	ADD12	H2	ADD3	L2	DATA13
B3	RESET	E3	ADD18	H3	ADD5	L3	DATA8
B4	KEYPADROW1	E4	ADD15	H4	VDD	L4	UBS
B5	KEYPADROW5	E5	ADD19	H5	GND	L5	DATA4
B6	KEYPADCOL2	E6	KEYPADROW3	H6	FLASHPWD	L6	DATA0
B7	GND	E7	KEYPADCOL3	H7	SIMPROG	L7	WR
B8	GPIO3	E8	LCDCTL	H8	VDD	L8	GPIO0
B9	GPIO7	E9	SYNTHEN1	H9	VSCLK	L9	SIMDATAIP
B10	TXENABLE	E10	TXPHASE	H10	VSDO	L10	SIMCARD
B11	AGCA	E11	GND	H11	CLKOUT	L11	TDO
B12	SYNTHDATA	E12	ASDO	H12	RXON	L12	JTAGEN
C1	GPIO10	F1	VDD	J1	ADD2	M1	DATA12
C2	USCRTS	F2	ADD10	J2	RAMCS	M2	DATA11
C3	USCTX	F3	ADD14	J3	ADD0	M3	RD
C4	KEYPADROW2	F4	GND	J4	DATA14	M4	LWR
C5	KEYPADCOL0	F5	ADD8	J5	DATA7	M5	DATA5
C6	OSC13MON	F6	DISPLAYCS	J6	DATA2	M6	DATA1
C7	GPIO4	F7	BSDO	J7	GPIO1	M7	VDD
C8	GPIO6	F8	VDDRTC	J8	SIMCLK	M8	GND
C9	RADIOPWRCTL	F9	GPIO2	J9	TMS	M9	SIMSUPPLY
C10	CALIBRATERADIO	F10	BSCLK	J10	EEPROMCLK	M10	SIMDATAOP
C11	SYNTHEN0	F11	ASOFS	J11	VSFS	M11	TCK
C12	OSCIN	F12	ASCLK	J12	VSDI	M12	TDI

This Information applies to a product under development. Its characteristics and specifications are subject to change without notice. Analog Devices assumes no obligation regarding future manufacture unless otherwise agreed to in writing. No responsibility is assumed by Analog Devices for its use; nor for any infringements of patents or other rights of third parties which may result from its use. No license is granted by implication or otherwise under any patent or patent rights of Analog Devices.

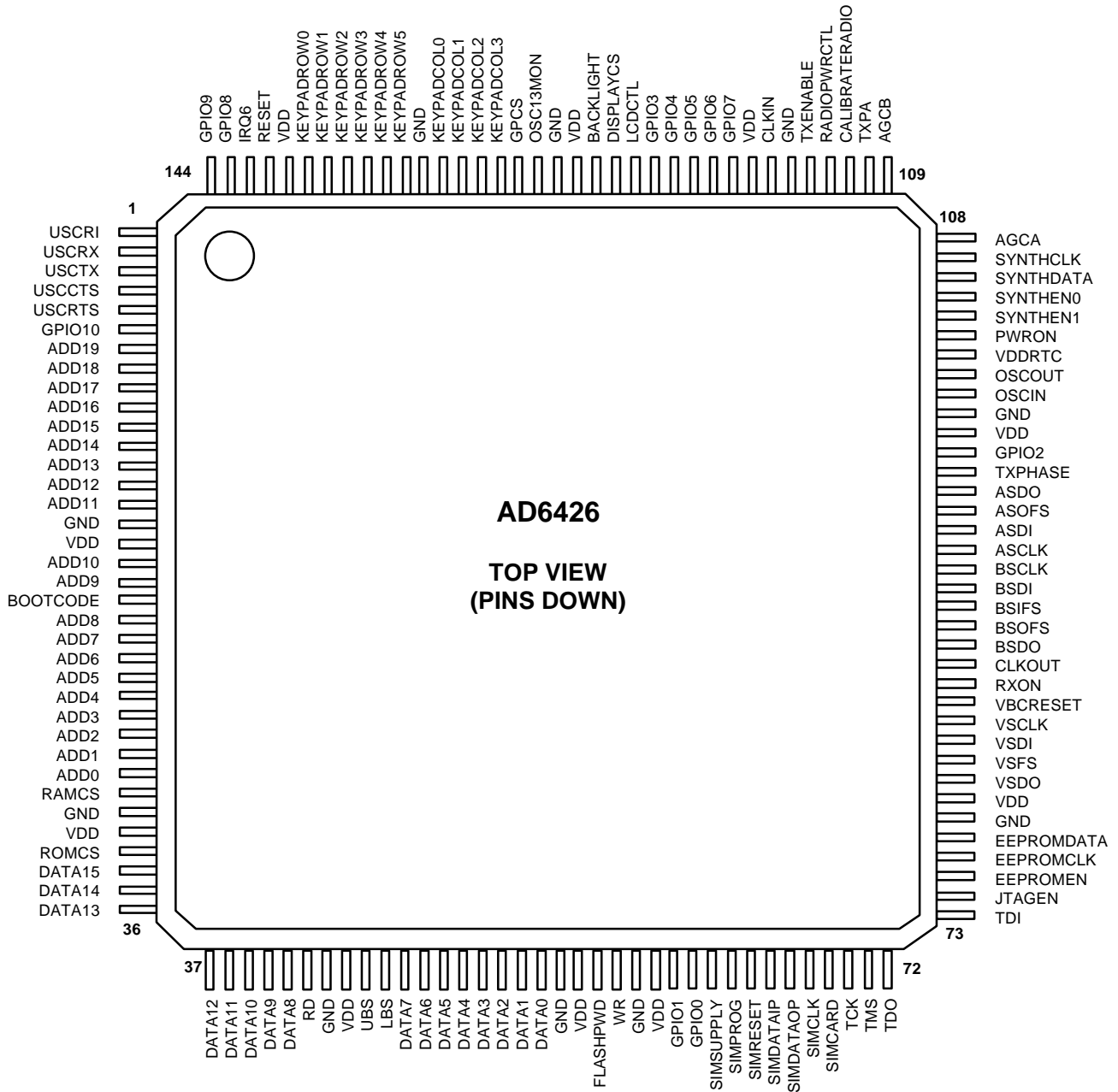
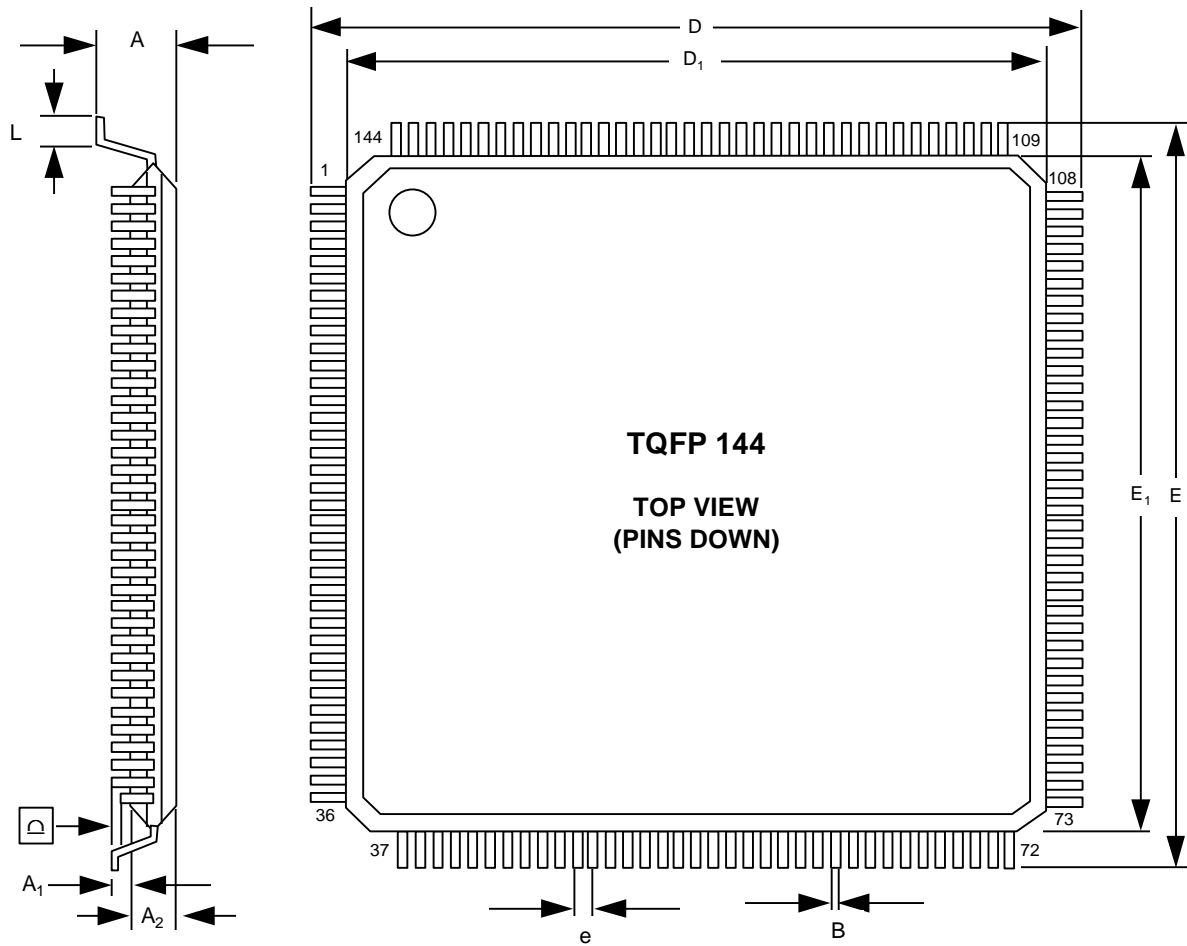

Figure 24: LQFP Pin Locations

This Information applies to a product under development. Its characteristics and specifications are subject to change without notice. Analog Devices assumes no obligation regarding future manufacture unless otherwise agreed to in writing. No responsibility is assumed by Analog Devices for its use; nor for any infringements of patents or other rights of third parties which may result from its use. No license is granted by implication or otherwise under any patent or patent rights of Analog Devices.

LQFP Outline Dimensions



DIM	MILLIMETERS			INCHES		
	MIN	TYP	MAX	MIN	TYP	MAX
A			1.60			0.063
A <sub>1</sub>	0.05		0.15	0.002		0.006
A <sub>2</sub>	1.35	1.40	1.45	0.053	0.055	0.057
D, E	21.80	22.00	22.20	0.858	0.866	0.874
D <sub>1</sub> , E <sub>1</sub>	19.90	20.00	20.10	0.783	0.787	0.791
L	0.5	0.6	0.75	0.019	0.024	0.030
e		0.50			0.020	
B	0.17	0.22	0.27	0.007	0.009	0.011
C			0.08			0.003

This Information applies to a product under development. Its characteristics and specifications are subject to change without notice. Analog Devices assumes no obligation regarding future manufacture unless otherwise agreed to in writing. No responsibility is assumed by Analog Devices for its use; nor for any infringements of patents or other rights of third parties which may result from its use. No license is granted by implication or otherwise under any patent or patent rights of Analog Devices.

PBGA Outline Dimensions

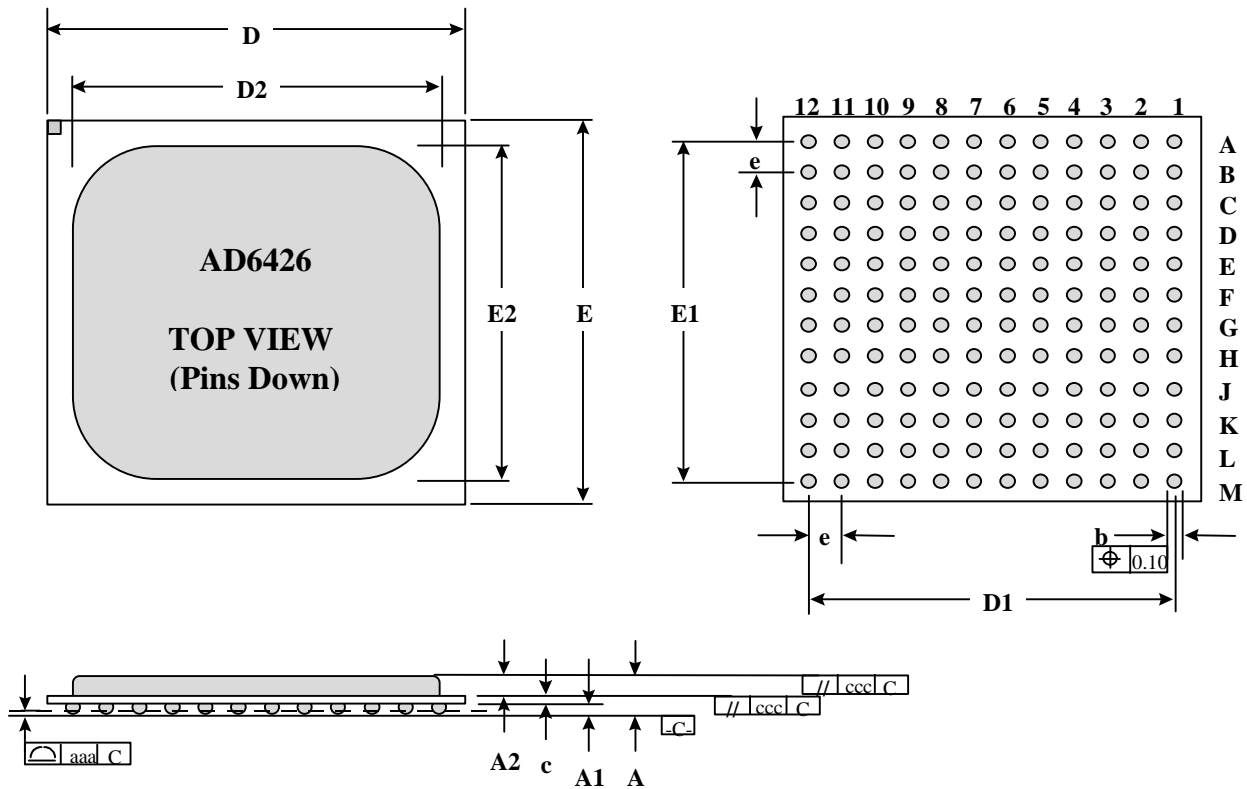

DIM	MILLIMETERS			INCHES		
	MIN	TYP	MAX	MIN	TYP	MAX
A	1.42	1.65	1.80	0.05591	0.06496	0.07087
A1	0.30	0.40	0.50	0.01181	0.01575	0.01968
A2	0.75	0.90	0.97	0.02953	0.03543	0.03819
D	12.85	13.00	13.15	0.50590	0.51181	0.51772
D1	11.00 BSC			0.43307 BSC		
D2	9.95	10.75	11.55	0.39173	0.42323	0.45472
E	12.85	13.00	13.15	0.50591	0.51181	0.51772
E1	11.00 BSC			0.43307 BSC		
E2	9.95	10.75	11.55	0.39173	0.42323	0.45472
b	0.45	0.55	0.65	0.17716	0.02165	0.02559
c	0.27	0.35	0.43	0.01063	0.01378	0.01693
e	1.00 BSC			0.03937 BSC		
aaa			0.15			0.00591
bbb			0.20			0.00787
ccc			0.25			0.00984

**NOTE:**

1. BSC - Between Spacing Centers

This Information applies to a product under development. Its characteristics and specifications are subject to change without notice. Analog Devices assumes no obligation regarding future manufacture unless otherwise agreed to in writing. No responsibility is assumed by Analog Devices for its use; nor for any infringements of patents or other rights of third parties which may result from its use. No license is granted by implication or otherwise under any patent or patent rights of Analog Devices.



## AD6426 Data Sheet Change Summary

AD6426 Preliminary Revision 2.3 (Changes from Revision 1.0)		
Number	Date	Description of Change
1	5/19/98	Motorola Serial Display mode added.
2	5/19/98	TXENABLE NMI function freeing up the IRQ6 pin added.
3	5/19/98	Dimensional tolerances for BGA package outline drawing added.
4	5/19/98	Memory I/F timing specs separated into characteristics and requirements.
5	5/19/98	Dual band control signals renamed- BANDSELECT0 is multiplexed with GPIO[2], BANDSELECT1 is multiplexed with GPIO[1]. For DB radios requiring a single Bandselect bit, BANDSELECT0 is enabled. For DB radios requiring 2 Bandselect bits then both BANDSELECT0,1 can be enabled. These signals were previously referred to as BANDSELECT and DCSSEL.
6	5/19/98	VBC and radio I/F diagram in Figure 6 updated to show a generic DB radio I/F.
7	5/19/98	DAI I/F Pins updated to be consistent with DAI Box users manual.
8	5/19/98	GPIO[7:0] Pin functions in Mode D (Table 24) were incorrectly listed as being all Tristate outputs. The correct function is GPIO7 = TRI and GPIO[6:0] = O.
9	5/20/98	Requirements for 32kHz crystal for slow clocking added.
10	5/20/98	Pin functions in Emulation mode GPO 0,6,7 in Table 24 are renamed to reserve.
11	5/20/98	Memory Interface Timing Specification: read timing specs changed to max with the exception of Control Processor data hold and Parameters broken out separately into requirements and characteristics.
12	6/9/98	In Fig 24 the following pins were incorrectly labeled and thus changed; a) Pin 45 from HWR to UBS b) Pin 46 from LWR to LBS c) Pin 98 from GND to VDD d) Pin 99 from VDD to GND

## AD6426 Data Sheet Change Summary

AD6426 Preliminary Revision 1.0 (Changes from Revision 0.1)		
Number	Date	Description of Change
1	1/15/98	Dallas I/F added to Feature list.
2	1/15/98	Dallas I/F enable bit polarity changed from logic 1 to 0.
3	1/15/98	Dual Band control section added describing BANDSELECT and DCSSEL signals.
4	1/15/96	Serial Display Interface Timing Characteristics and Diagram added as Figure 23.
5	1/15/98	General Description: F7.2 data services deleted, this is not supported on the EGSMP.
6	1/15/98	General Description: AD6421/25 interfaces to the EGSMP.
7	1/15/98	Serial Display Reset signal removed from Figure 2. Display driver chip reset input is connected to the AD6425 VBC Reset Input and both are driven by the AD6426 VBC reset output.
8	1/15/98	Pin Functionality: VBCRESET added note, also used for Display Reset.
9	1/15/98	Pin Functionality: GPIO1 added note, alternate function DCS_ON.
10	1/15/98	CC Control Registers: Interrupt counter (Addr. 48) changed from 7 to 8 bits.
11	1/15/98	SIM Interface timing characteristics deleted - SIM signals are completely asynchronous with respect to SIMCLK.
12	1/15/98	Plastic Ball Grid Array (PBGA) Package pinout and outline drawing added.
13	2/16/98	EVBC and radio Interface block diagram in Figure 6 updated with dual band control signals.
14	2/16/98	$V_{CLKIN}$ , Clock Input Voltage for ac-coupled sine wave input changed from 100 mV <sub>PP</sub> to 250 mV <sub>PP</sub> .
15	2/16/98	Added scan registers USCRX (O), USCRXEN (B), and VSDOEN (T) Corrected output polarity in Notes to active-low (0=output).
16	2/16/98	Added H8 Control registers and register contents in Tables 3 and 4.
17	2/16/98	Buffered UART Register Contents added in Table 5.
18	2/26/98	$I_{IH}$ , $I_{IL}$ Input Current spec min -10, max 10 $\mu$ A added.
19	2/26/98	$I_{IH}$ , $I_{IL}$ Input Current spec min -10, max 10 $\mu$ A added.
20	2/26/98	$I_{OZL}$ , Low Level Output 3-State Leakage Current min 10, max 10 $\mu$ A $I_{OZH}$ , High Level Output 3-State Leakage Current min 10, max 10 $\mu$ A.
21	2/26/98	Absolute Max ratings broken out separately for PBGA package.
22	2/26/98	Control Processor Data setup time changed from 10 to 68 ns.
23	2/26/98	Radio interface section: a reference to the TTP/Hitachi radios added "AD6426 Radio Interface supports radio architectures based on Siemens, Philips, and TTP/Hitachi RF chipsets".
24	2/27/98	Pin Functionality: OSC13MON pin moved from RTC section to general section.
25	2/27/98	Memory interface timing diagram replaced with one used in 6422 data sheet.
26	2/27/98	CC register 46 bits 4-7 SIMCLOCK Polarity, SIMCLOCK off. SIMCLOCK Control, STBYCLKON removed no longer used on 6426.
27	3/9/98	CC registers 80-87 slow clocking control removed from Table 1 & 2 per TTP's request.
28	3/9/98	Peripheral registers 83, 106-109 removed from Table 3 & 4 per TTP's request.
29	3/9/98	All Buffered UART registers removed per TTP's request.