

FM220-S THRU FM2200-S

List

List.....	1
Package outline.....	2
Features.....	2
Mechanical data.....	2
Maximum ratings and Electrical characteristics	2
Rating and characteristic curves.....	3
Pinning information.....	4
Marking.....	4
Suggested solder pad layout.....	4
Packing information.....	5
Reel packing.....	6
Suggested thermal profiles for soldering processes.....	6
High reliability test capabilities.....	7

FM220-S THRU FM2200-S

2.0A Surface Mount Schottky Barrier Rectifiers 20V-200V

Features

- Batch process design, excellent power dissipation offers better reverse leakage current and thermal resistance
- Low profile surface mounted application in order to optimize board space.
- Low power loss, high efficiency
- High current capability, low forward voltage drop
- High surge capability
- Guardring for overvoltage protection
- Ultra high-speed switching
- Silicon epitaxial planar chip, metal silicon junction
- Lead-free parts meet RoHS requirements
- Suffix "-H" indicates Halogen free parts, ex. FM220-S-H

Mechanical data

- Epoxy: UL94-V0 rated flame retardant
- Case : Molded plastic, SMA-S
- Terminals : Solder plated, solderable per MIL-STD-750, Method 2026
- Polarity : Indicated by cathode band
- Mounting Position : Any
- Weight : Approximated 0.05 gram

Package outline

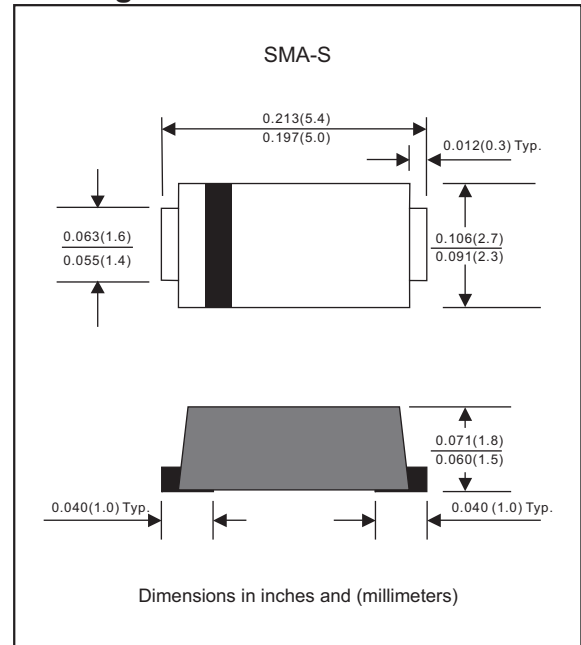

Maximum ratings (AT T_A=25°C unless otherwise noted)

PARAMETER	SYMBOLS	FM220-S	FM230-S	FM240-S	FM245-S	FM250-S	FM260-S	FM280-S	FM2100-S	FM2150-S	FM2200-S	UNIT	
Maximum repetitive peak reverse voltage	V _{RRM}	20	30	40	45	50	60	80	100	150	200	V	
Maximum RMS voltage	V _{RMS}	14	21	28	31.5	35	42	56	70	105	140	V	
Maximum continuous reverse voltage	V _R	20	30	40	45	50	60	80	100	150	200	V	
Maximum average forward rectified current	I _O	2.0										A	
Non-repetitive peak forward surge current 8.3ms single half sine-wave	I _{FSM}	50										A	
Typical junction capacitance (Note 1)	C _J	110			80			60		45		35	pF
Operating junction temperature range	T _J	-55 to +125					-55 to +150						°C
Storage temperature range	T _{STG}	-65 to +175										°C	

Electrical characteristics (AT T_A=25°C unless otherwise noted)

PARAMETER	SYMBOLS	FM220-S	FM230-S	FM240-S	FM245-S	FM250-S	FM260-S	FM280-S	FM2100-S	FM2150-S	FM2200-S	UNIT	
Maximum instantaneous forward voltage at I _F =2.0A	V _F	0.50				0.70		0.85		0.90		0.92	V
Maximum reverse leakage current at rated V _R	I _R						0.5						mA
							10						mA

Thermal characteristics

PARAMETER	SYMBOLS	FM220-S	FM230-S	FM240-S	FM245-S	FM250-S	FM260-S	FM280-S	FM2100-S	FM2150-S	FM2200-S	UNIT	
Typical thermal resistance junction to ambient (Note2)	R _{θJA}	64											°C/W
Typical thermal resistance junction to case (Note 2)	R _{θJC}	32											°C/W

Notes1: Measured at 1MHz and applied reverse voltage of 4.0V D.C

2: Mounted on FR-4 PCB copper, minimum recommended pad layout

Rating and characteristic curves (FM220-S THRU FM2200-S)

FIG.1-TYPICAL FORWARD CURRENT DERATING CURVE

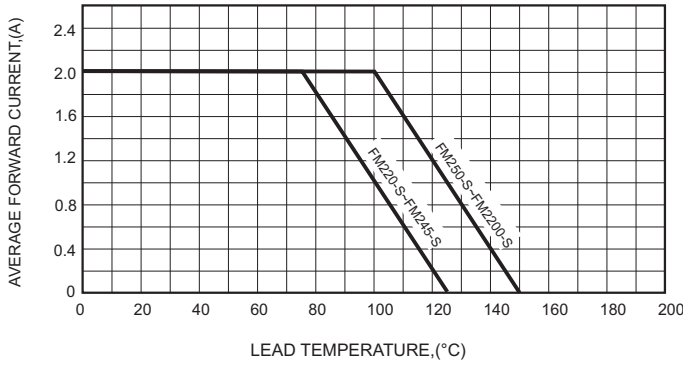

FIG.2-TYPICAL FORWARD CHARACTERISTICS

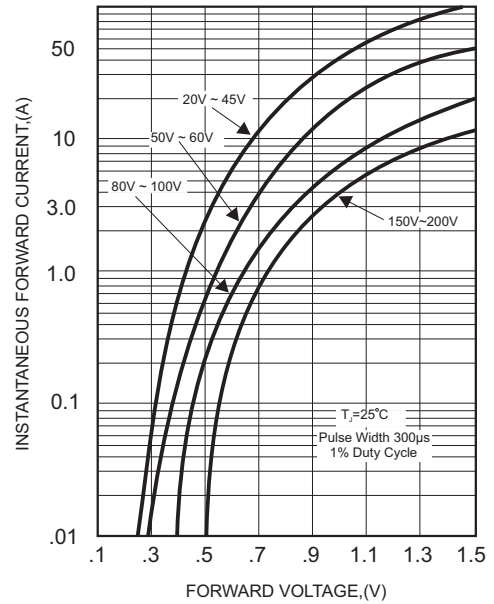

FIG.3-MAXIMUM NON-REPETITIVE FORWARD SURGE CURRENT

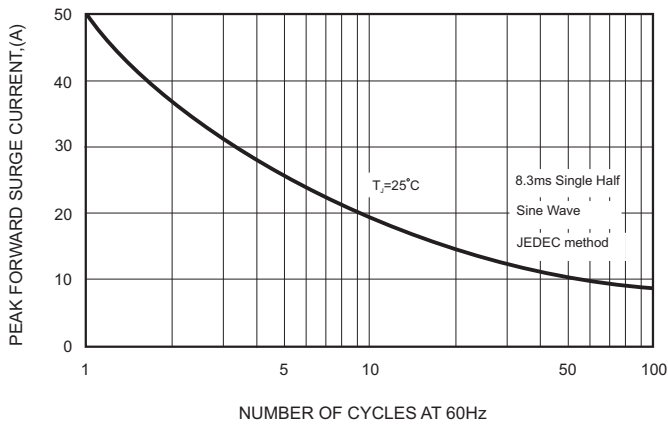

FIG.5 - TYPICAL REVERSE CHARACTERISTICS

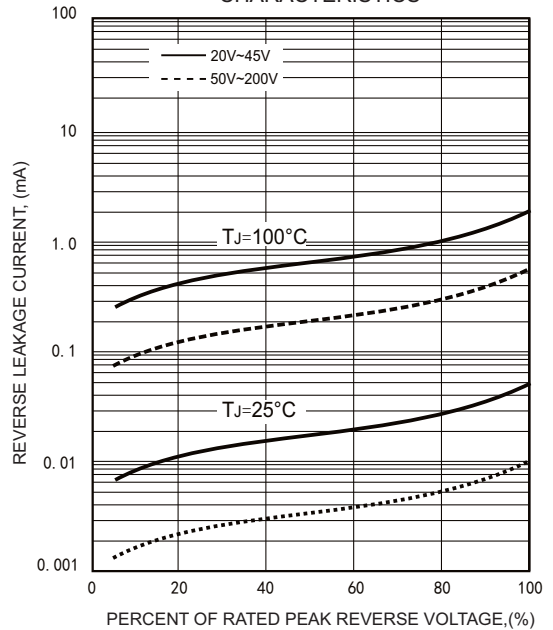
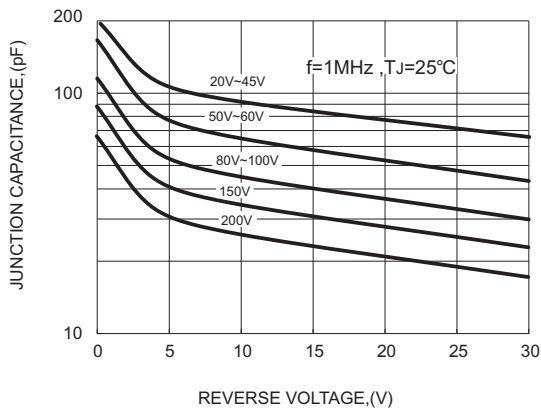



FIG.4-TYPICAL JUNCTION CAPACITANCE



FM220-S THRU FM2200-S

Pinning information

Pin	Simplified outline	Symbol
Pin1 cathode Pin2 anode		

Marking

Type number	Marking code
FM220-S	SK22
FM230-S	SK23
FM240-S	SK24
FM245-S	SK24
FM250-S	SK25
FM260-S	SK26
FM280-S	SK28
FM2100-S	S210
FM2150-S	S215
FM2200-S	S220

Suggested solder pad layout

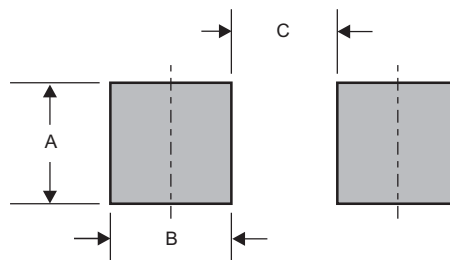

Dimensions in inches and (millimeters)

PACKAGE	A	B	C
SMA-S	0.063 (1.60)	0.059 (1.50)	0.110 (2.80)

FM220-S THRU FM2200-S

Packing information

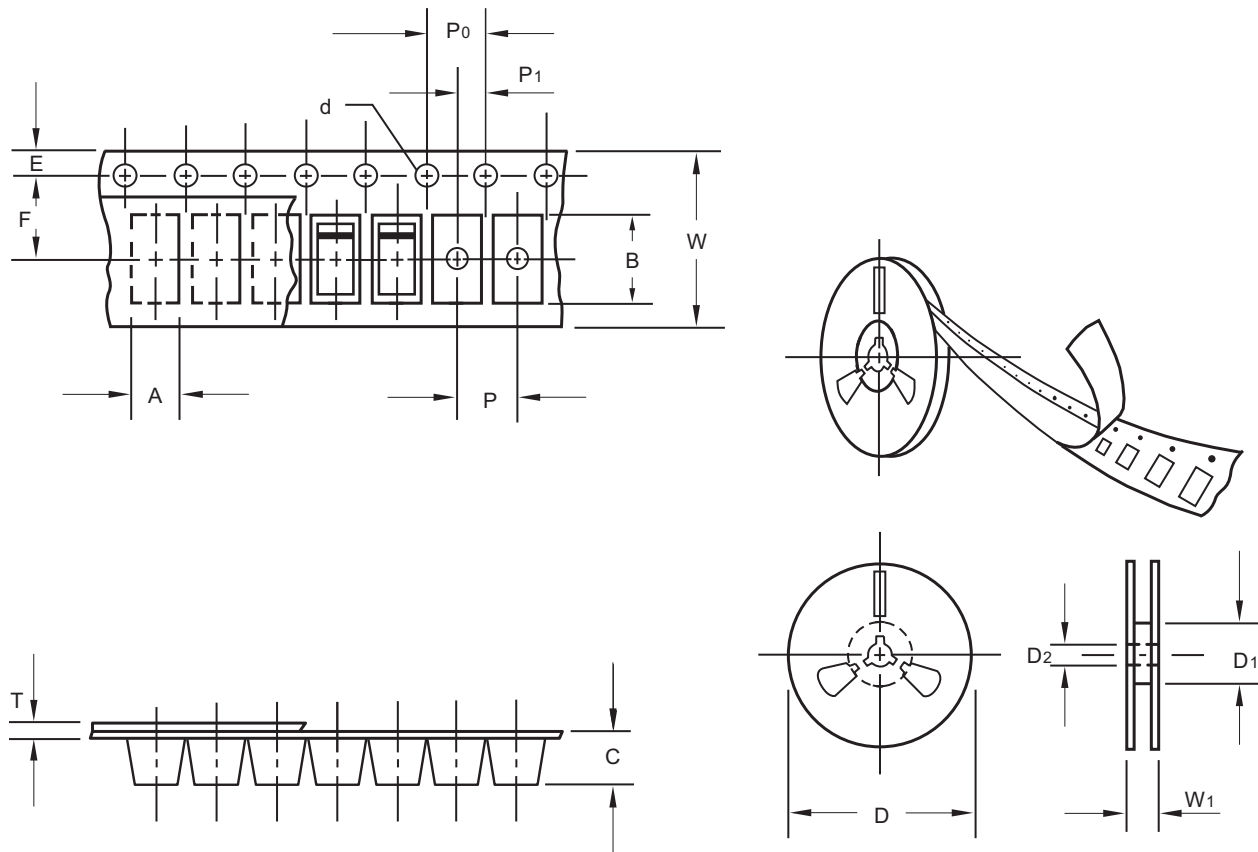

unit:mm

Item	Symbol	Tolerance	SMA-S
Carrier width	A	0.1	2.90
Carrier length	B	0.1	5.50
Carrier depth	C	0.1	2.10
Sprocket hole	d	0.1	1.50
13" Reel outside diameter	D	2.0	330.00
13" Reel inner diameter	D1	min	50.00
7" Reel outside diameter	D	2.0	178.00
7" Reel inner diameter	D1	min	62.00
Feed hole diameter	D2	0.5	13.00
Sprocket hole position	E	0.1	1.75
Punch hole position	F	0.1	5.50
Punch hole pitch	P	0.1	4.00
Sprocket hole pitch	P0	0.1	4.00
Embossment center	P1	0.1	2.00
Overall tape thickness	T	0.1	0.23
Tape width	W	0.3	12.00
Reel width	W1	1.0	18.00

Note: Devices are packed in accordance with EIA standard RS-481-A and specifications listed above.

FM220-S THRU FM2200-S

Reel packing

PACKAGE	REEL SIZE	REEL (pcs)	COMPONENT SPACING (m/m)	BOX (pcs)	INNER BOX (m/m)	REEL DIA, (m/m)	CARTON SIZE (m/m)	CARTON (pcs)	APPROX. GROSS WEIGHT (kg)
SMA-S	7"	2,000	4.0	20,000	183*155*183	178	382*356*392	160,000	15.0
	13"	7,500	4.0	15,000	335*335*38	330	350*330*360	120,000	14.5

Suggested thermal profiles for soldering processes

- 1.Storage environment: Temperature=5°C~40°C Humidity=55%±25%
- 2.Reflow soldering of surface-mount devices

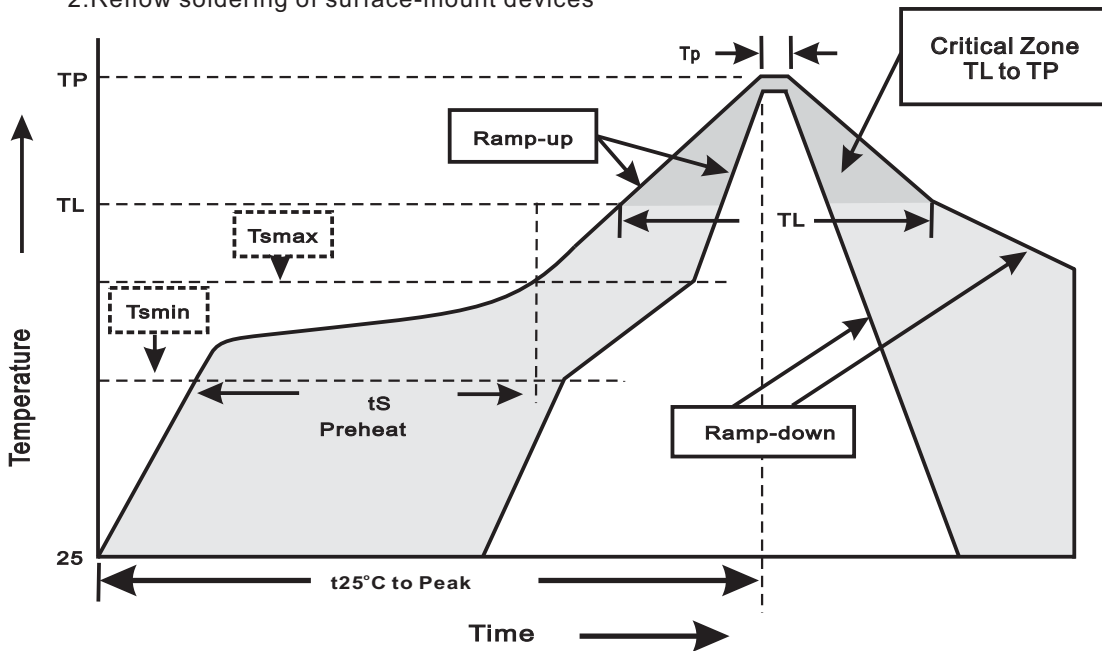

3.Reflow soldering

Profile Feature	Soldering Condition
Average ramp-up rate(T _L to T _P)	<3°C/sec
Preheat -Temperature Min(T _{Amin}) -Temperature Max(T _{Smax}) -Time(min to max)(t _S)	150°C 200°C 60~120sec
T _{Smax} to T _L -Ramp-upRate	<3°C/sec
Time maintained above: -Temperature(T _L) -Time(t _L)	217°C 60~260sec
Peak Temperature(T _P)	255°C-0/+5°C
Time within 5°C of actual Peak Temperature(t _P)	10~30sec
Ramp-down Rate	<6°C/sec
Time 25°C to Peak Temperature	<6minutes

FM220-S THRU FM2200-S**High reliability test capabilities**

Item Test	Conditions	Reference
1. Solder Resistance	at 260±5°C for 10±2sec.	MIL-STD-750D METHOD-2031
2. Solderability	at 245±5°C for 5 sec.	MIL-STD-202F METHOD-208
3. High Temperature Reverse Bias	$V_R=80\%$ rate at $T_J=125^\circ\text{C}$ for 168 hrs.	MIL-STD-750D METHOD-1038
4. Forward Operation Life	Rated average rectifier current at $T_A=25^\circ\text{C}$ for 500hrs.	MIL-STD-750D METHOD-1027
5. Intermittent Operation Life	$T_A = 25^\circ\text{C}$, $I_F = I_O$ On state: power on for 5 min. off state: power off for 5 min. on and off for 500 cycles.	MIL-STD-750D METHOD-1036
6. Pressure Cooker	15P _{SIG} at $T_A=121^\circ\text{C}$ for 4 hrs.	JESD22-A102
7. Temperature Cycling	-55°C to +125°C dwelled for 30 min. and transferred for 5min. total 10 cycles.	MIL-STD-750D METHOD-1051
8. Forward Surge	8.3ms single half sine-wave , one surge.	MIL-STD-750D METHOD-4066-2
9. Humidity	at $T_A=85^\circ\text{C}$, RH=85% for 1000hrs.	MIL-STD-750D METHOD-1021
10. High Temperature Storage Life	at 175°C for 1000 hrs.	MIL-STD-750D METHOD-1031