



# **GD9Fx4GxF4B GD9Fx8GxE4B**

## **DATASHEET**

*4Gb/8Gb 4K+256B Page Size NAND Flash*



# Contents

- 1. FEATURES .....4**
- 2. GENERAL DESCRIPTION .....5**
  - 2.1 PRODUCT LIST ..... 5
- 3. PACKAGE .....6**
  - 3.1 TSOPI-48 ..... 6
  - 3.2 FBGA-63 ..... 6
  - 3.3 FBGA-67 ..... 7
- 4. BLOCK DIAGRAM .....8**
  - 4.1 PIN DESCRIPTION ..... 9
- 5. ARRAY ORGANIZATION .....10**
  - 5.1 ADDRESSING (8BIT) ..... 11
  - 5.2 ADDRESSING (16BIT) ..... 11
  - 5.3 FACTORY DEFECT MAPPING ..... 12
    - 5.3.1. *Device Requirements* ..... 12
    - 5.3.2. *Host Requirements* ..... 13
- 6. COMMAND SET .....14**
- 7. BUS OPERATION .....15**
  - 7.1 COMMAND INPUT CYCLE ..... 16
  - 7.2 ADDRESS INPUT CYCLE ..... 16
  - 7.3 DATA INPUT CYCLE ..... 17
  - 7.4 DATA OUTPUT CYCLE ..... 18
  - 7.5 WRITE PROTECT ..... 19
- 8. OPERATION DESCRIPTION .....20**
  - 8.1 PAGE READ OPERATION ..... 20
    - 8.1.1 *Common Page Read (00H-30H)* ..... 20
    - 8.1.2 *Random Data Output (05H-E0H)* ..... 21
    - 8.1.3 *Cache Read Sequential (31H/3FH)* ..... 21
    - 8.1.4 *Cache Read Random (00H-31H)* ..... 22
    - 8.1.5 *Read for copy back (00H-35H)* ..... 23
    - 8.1.6 *Read Two Plane (00H-32H-00H-30H)* ..... 24
    - 8.1.7 *Read for Two-Plane Copy Back (00H-32H-00H-35H)* ..... 25
  - 8.2 PAGE PROGRAM OPERATION ..... 26
    - 8.2.1 *Common Page Program (80H-10H)* ..... 26
    - 8.2.2 *Page Program Operation with Random Data Input (85H)* ..... 27
    - 8.2.3 *Cache Program Operation (80H-15H)* ..... 27
    - 8.2.4 *Copy-Back Program with Random Data Input (85H-10H)* ..... 29



8.2.5 Multi-Plane Program (80H-11H-80/81H-10H)..... 30

8.2.6 Multi-Plane Copy Back Program (85H-11H-85H-10H)..... 31

8.3 BLOCK ERASE OPERATION..... 32

8.3.1 Common Block Erase Operation (60H-D0H)..... 32

8.3.2 Multi-Plane Block Erase Operation (60H-60H-D0H) ..... 33

8.3.3 Multi-Plane Block Erase Operation-ONFI (60H-D1H)..... 33

8.4 RESET ..... 34

8.4.1 Reset (FFH)..... 34

8.5 READ DEVICE INFORMATION ..... 35

8.5.1 Read ID and ONFI Signature (90H)..... 35

8.5.2 Read Unique ID (EDH)..... 39

8.5.3 Read Parameter Page (ECH) ..... 40

8.6 READ STATUS (70H) ..... 46

8.7 READ STATUS ENHANCED – ONFI (78H) ..... 48

8.8 READY/BUSY# (R/B#) ..... 49

8.9 DATA PROTECTION & POWER ON/OFF SEQUENCE ..... 50

8.10 MULTI-PLANE OPERATION LIMITATION ..... 51

8.11 ADDRESSING FOR PROGRAM OPERATION..... 52

8.12 SEVERAL PROGRAMMING CYCLES ON THE SAME PAGE (PARTIAL PAGE PROGRAM) ..... 53

**9. ABSOLUTE MAXIMUM RATINGS ..... 54**

**10. VALID BLOCKS ..... 55**

**11. DC CHARACTERISTICS..... 56**

**12. AC CHARACTERISTICS..... 57**

12.1 TEST CONDITION ..... 57

12.2 CAPACITANCE (TA=25°C, F=1.0 MHz) ..... 57

12.3 AC TIMING CHARACTERISTICS..... 58

12.4 PERFORMANCE CHARACTERISTICS..... 59

**13. PACKAGE INFORMATION ..... 60**

13.1 TSOPI-48 ..... 60

13.2 FBGA-63..... 62

13.3 FBGA-67..... 64

**14. PART NUMBERING INFORMATION ..... 65**

**15. REVISION HISTORY..... 66**



# 1. FEATURES

- ◆ Single level cell technology
- ◆ ONFI 1.0 Compatible
- ◆ Power Supply Voltage
  - VCC = 1.7v ~ 1.95v
  - VCC = 2.7v ~ 3.6v
- ◆ Memory Cell Organization
  - Page size:
    - X8: 4K + 256 bytes
    - X16: 2K + 128 words
  - Block size: 64 Pages
    - X8: 256K + 16K bytes
    - X16: 128K + 8K words
  - Plane size: 1024 blocks
  - Device size:
    - 4Gb:2048 blocks
    - 8Gb:4096 blocks
- ◆ Page Read / Program time
  - Random Read Time (tR): 25us Max.
  - Sequential Access Time
    - 3.3v Device: 25ns Min.
    - 1.8v Device: 30ns Min.
  - Page Program (tPROG): 300us Typ.
- ◆ Block Erase
  - Block Erase Time(tBERS): 3ms Typ.
- ◆ Advantage Feature
  - cache read
  - multi-plane operation
- ◆ Operating Current
  - Read(Typ): 15mA
  - Program(Typ): 15mA
  - Erase(Typ): 30mA
  - Standby(max): 50uA per LUN for CMOS
- ◆ Reliability
  - P/E cycles with ECC: 50K
  - Data retention: 10 Years
- ◆ ECC Requirement
  - 8bit/512 byte
- ◆ Operating Temperature
  - Industrial: -40C ~ 85C
- ◆ Chip Enable Don't Care Option
- ◆ Security
  - OTP area
  - UID
- ◆ Package
  - TSOPI 48 12mm x 20mm
  - FBGA 63 9mm x 11mm
  - FBGA 67 6.5mm x 8mm



## 2. GENERAL DESCRIPTION

GigaDevice GD9Fx4GxF4B/GD9Fx8GxE4B is 4Gbit/8Gbit capacity. A program operation can be performed in typical tPROG on each page and an erase operation can be performed in typical tBERS on each block. Data in the page can be read out at tRC cycle time per byte. The I/O pins serve as the ports for address and data input/output as well as command input.

### 2.1 Product List

PART NUMBER	ORGANIZATION	VCC RANGE	PACKAGE
GD9FU4G8F4B	512M x 8bit	2.7v ~ 3.6v	TSOP-48/FBGA-63/FBGA-67
GD9FU4G6F4B	256M x 16bit	2.7v ~ 3.6v	TSOP-48/FBGA-63/FBGA-67
GD9FS4G8F4B	512M x 8bit	1.7v ~ 1.95v	TSOP-48/FBGA-63/FBGA67
GD9FS4G6F4B	256M x 16bit	1.7v ~ 1.95v	TSOP-48/FBGA-63/FBGA-67
GD9FU8G8E4B	1G x 8bit	2.7v ~ 3.6v	TSOP-48/FBGA-63
GD9FU8G6E4B	512M x 16bit	2.7v ~ 3.6v	TSOP-48/FBGA-63
GD9FS8G8E4B	1G x 8bit	1.7v ~ 1.95v	TSOP-48/FBGA-63
GD9FS8G6E4B	512M x 16bit	1.7v ~ 1.95v	TSOP-48/FBGA-63

### 3. Package

#### 3.1 TSOPI-48

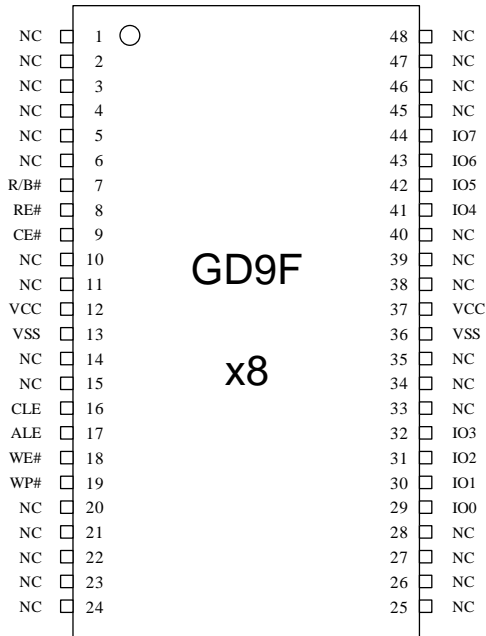

top view

Figure 3-1\_a: x8 Device

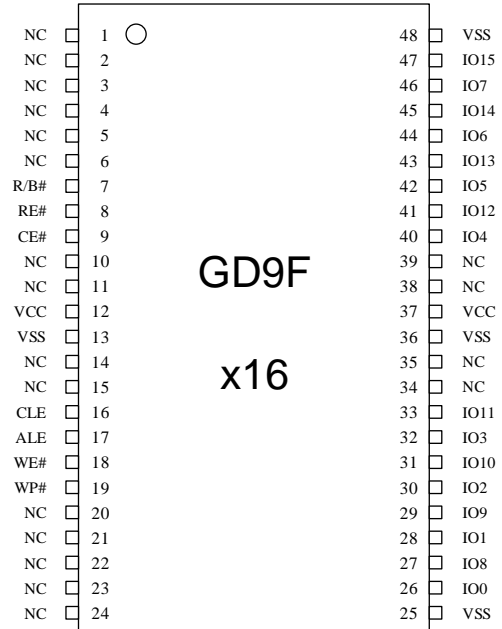

top view

Figure 3-1\_b: x16 Device

#### 3.2 FBGA-63

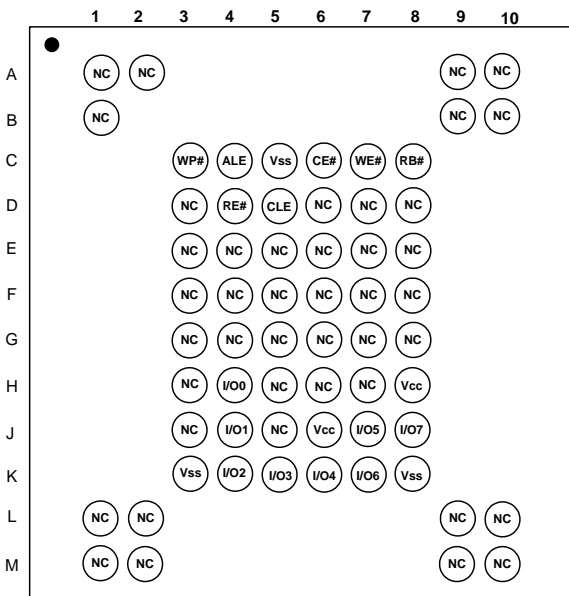

Figure 3-2\_a: 63-FBGA Contact, x8 device

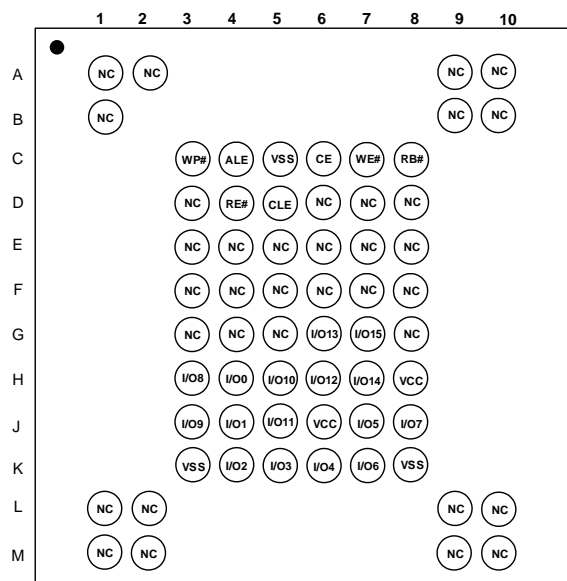
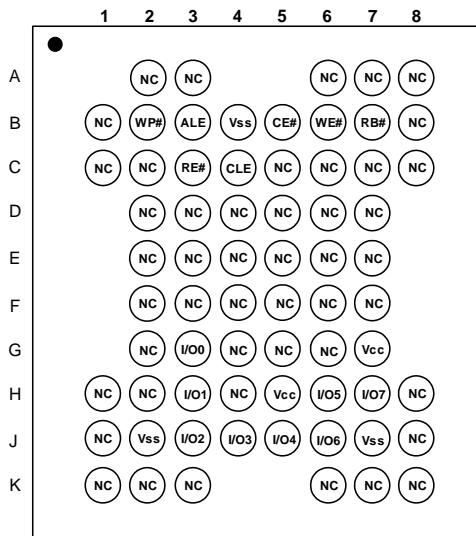

Figure 3-2\_b: 63-FBGA Contact, x16 device



### 3.3 FBGA-67



top view

Figure 3-3\_a: 67-FBGA Contact, x8 device

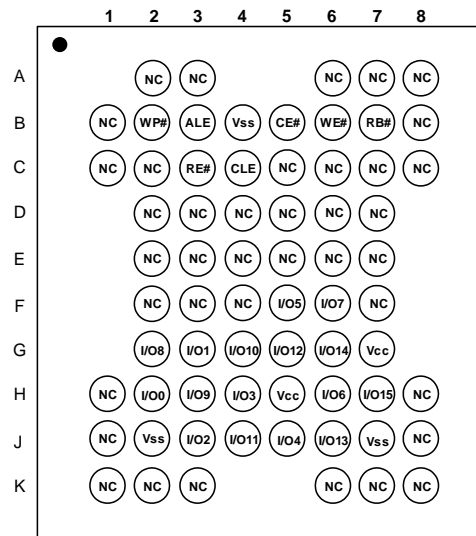

top view

Figure 3-3\_b: 67-FBGA Contact, x16 device



### 4. BLOCK DIAGRAM

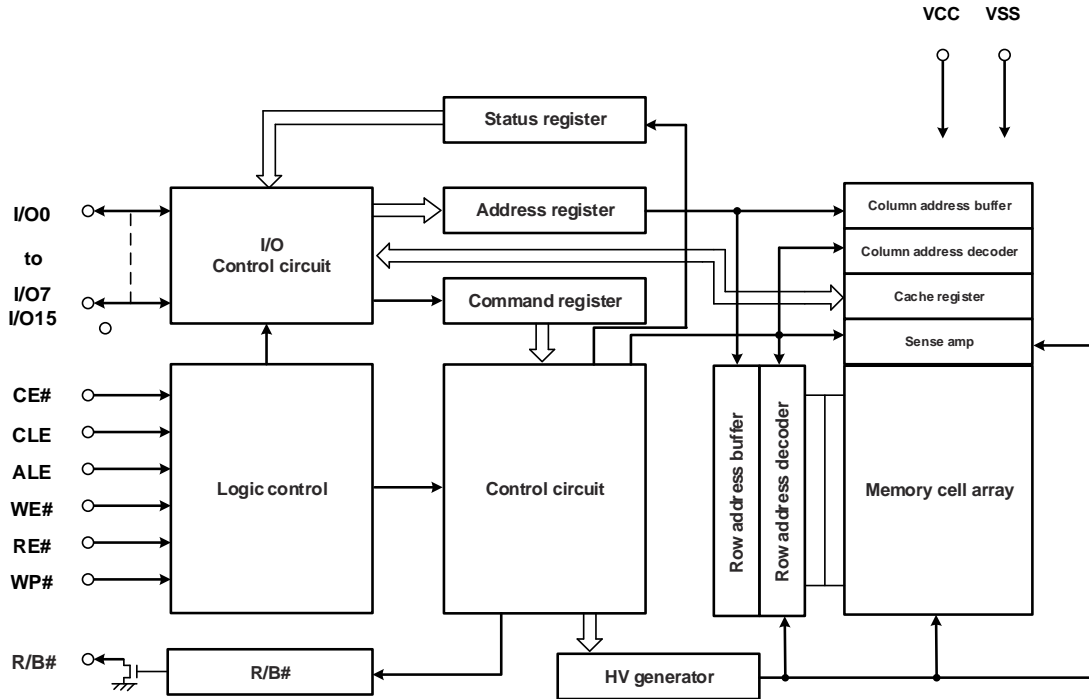

Figure 4-1: Block Diagram Figure





### 4.1 Pin Description

Signal Name	Input/ Output	Description
R/B#	O	Ready/Busy : Open drain output to indicate the target status, low to indicate that one or more operations are in progress.
RE#	I	Read Enable : Enables data output, active low.
CE#	I	Chip Enable : When high and the target is in the ready state, the target goes into a low-power standby state. When low, the target is selected.
CLE	I	Command Latch Enable : Enable signal to load a command into the target on the rising edge of WE#, active high.
ALE	I	Address Latch Enable : Enable signal to load an address into the target on the rising edge of WE#, active high.
WE#	I	Write Enable : Data, Commands, and Addresses are latched on the rising edge of WE#.
WP#	I	Write Protect : low to disable Flash array program and erase operations.
IO0 ~ IO7	I/O	I/O Port, bits 0-7 : 8-bit wide bidirectional port for transferring address, command, and data to and from the device.
IO8 ~ IO15	I/O	I/O Port, bits 8-15 : Upper 8 bits for the 16-bit wide bidirectional port used to transfer data to and from the device.
VCC	I	Power : Power supply to the device.
VSS	I	Ground : Power supply ground.
NC	-	No Connection : Lead is not internally connected.

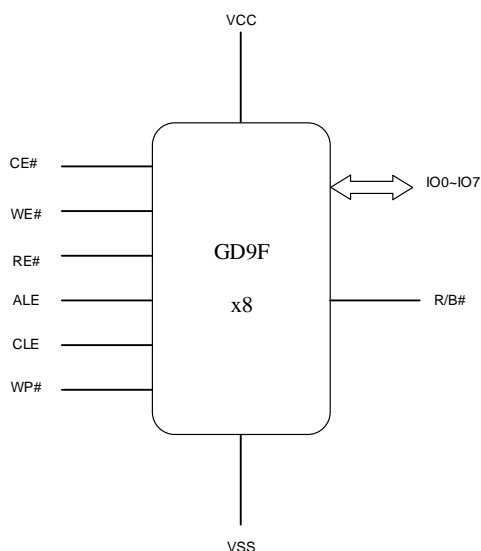

Figure 4-2\_a: x8 Device Figure

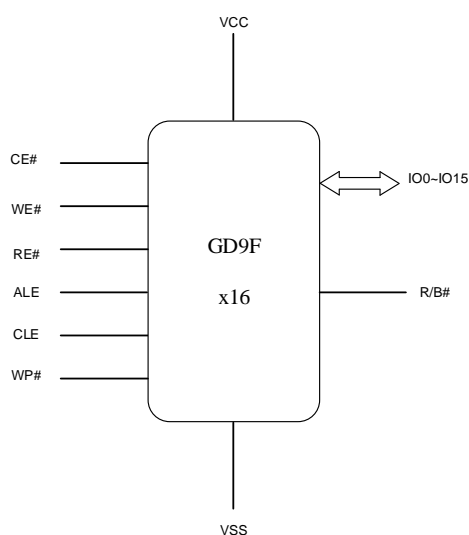

Figure 4-2\_b: x16 Device Figure

## 5. ARRAY ORGANIZATION

Each device has		Each block has	Each page has	
4G bits	8G bits			
512M+32M	1G+64M	256K+16K	4K+256	Bytes
2048 x 64	4096 x 64	64	-	Pages
2048	4096	-	-	Blocks

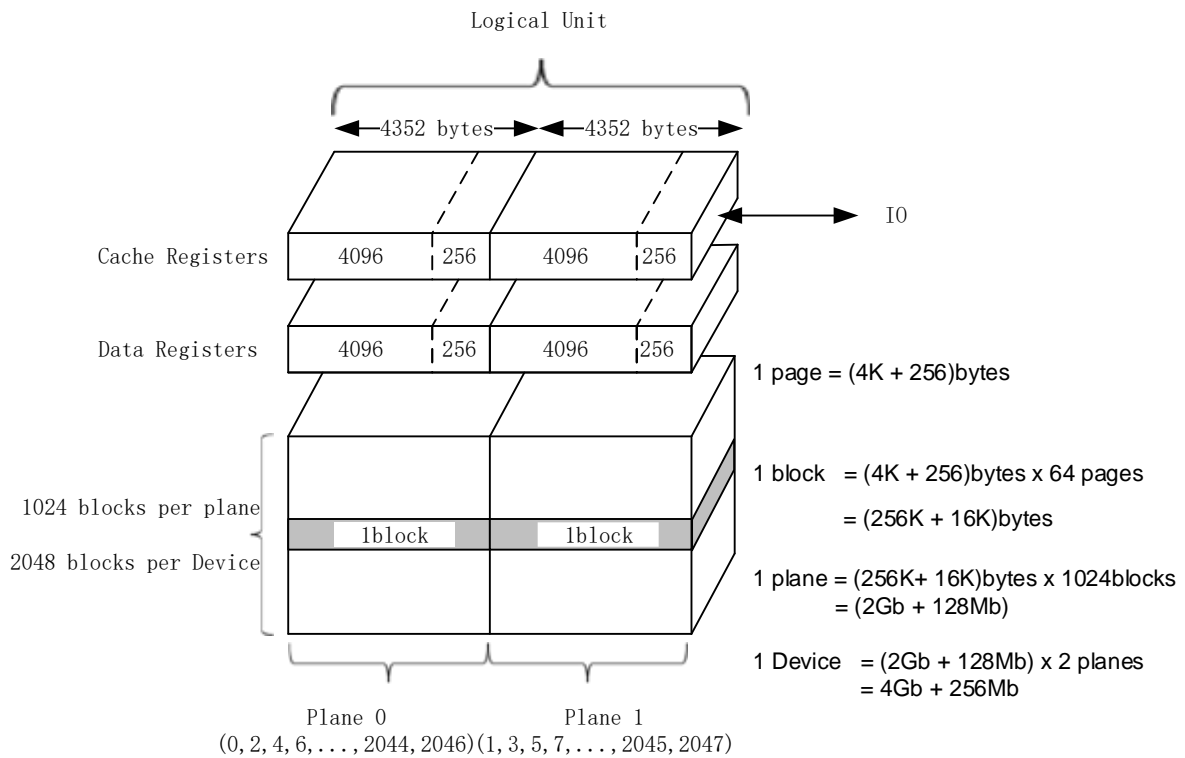

Figure 5-1: Array Organization Figure



## 5.1 Addressing (8bit)

Bus Cycle	IO0	IO1	IO2	IO3	IO4	IO5	IO6	IO7
1 <sup>st</sup> Cycle	A0	A1	A2	A3	A4	A5	A6	A7
2 <sup>nd</sup> Cycle	A8	A9	A10	A11	A12	L	L	L
3 <sup>rd</sup> Cycle	A13	A14	A15	A16	A17	A18	A19	A20
4 <sup>th</sup> Cycle	A21	A22	A23	A24	A25	A26	A27	A28
5 <sup>th</sup> Cycle	A29	A30*	L	L	L	L	L	L

A0-A12: column address in the page

A13-A18: page address in the block

A19: plane address (for multi-plane operations) / block address (for normal operations)

A19-A29: block address

A30-A31 is used for DDP with a single CE.

Note: For 4Gb, A30 is Low;

## 5.2 Addressing (16bit)

Bus Cycle	IO0	IO1	IO2	IO3	IO4	IO5	IO6	IO7
1 <sup>st</sup> Cycle	A0	A1	A2	A3	A4	A5	A6	A7
2 <sup>nd</sup> Cycle	A8	A9	A10	A11	L	L	L	L
3 <sup>rd</sup> Cycle	A12	A13	A14	A15	A16	A17	A18	A19
4 <sup>th</sup> Cycle	A20	A21	A22	A23	A24	A25	A26	A27
5 <sup>th</sup> Cycle	A28	A29*	L	L	L	L	L	L

A0-A11: column address in the page

A12-A17: page address in the block

A18: plane address (for multi-plane operations) / block address (for normal operations)

A18-A28: block address

A29-A30 is used for DDP with a single CE.

Note: For 4Gb, A29 is Low;



### 5.3 Factory Defect Mapping

The Flash array is not presumed to be pristine, and a number of defects that makes the blocks unusable may be present. Invalid blocks shall be sorted out from normal blocks by software.

#### 5.3.1. Device Requirements

If a block is defective, the manufacturer shall mark the block as defective by setting the Defective Block Marking, as shown in Figure of “the Area marked in first or last page of block indicating defect”, of the last page of the defective block to a value of non-FFh. The Defective Block Marking is located on the first byte of user data area or the first byte of spare data area in the pages within a block.

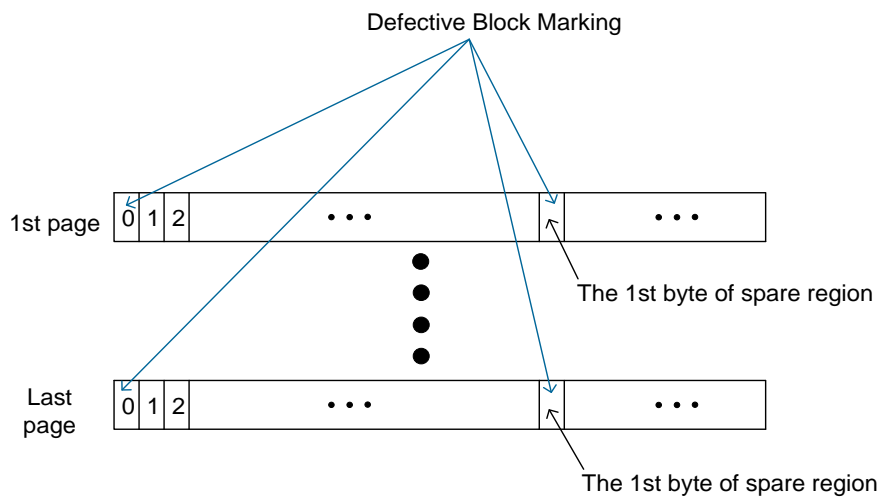

Figure 5-2:Area Marked In First Or Last Page Of Block Indicating Defect Figure



### 5.3.2. Host Requirements

The host shall not erase or program blocks marked as defective by the manufacturer, and any attempt to do so yields indeterminate results.

Figure of “Flow chart to create initial invalid block table” outlines the flow chart how to create an initial invalid block table. It should be performed by the host to create the initial bad block table prior to performing any erase or programming operations on the target. The 1st byte of both main and spare region in non-defective blocks are read FFh with ECC enabled on the controller. A defective block is indicated by the majority of bits being read non-FFh in the Defective Block Marking location of either the first page or last page of the block. The host shall check the Defective Block Marking location of both the first and last past page of each block to verify the block is valid prior to any erase or program operations on that block.

NOTE: Over the lifetime use of a NAND device, the Defective Block Marking of defective blocks may encounter read disturbs that cause bit changes. The initial defect marks by the manufacturer may change value over the lifetime of the device, and are expected to be read by the host and used to create a bad block table during initial use of the part.

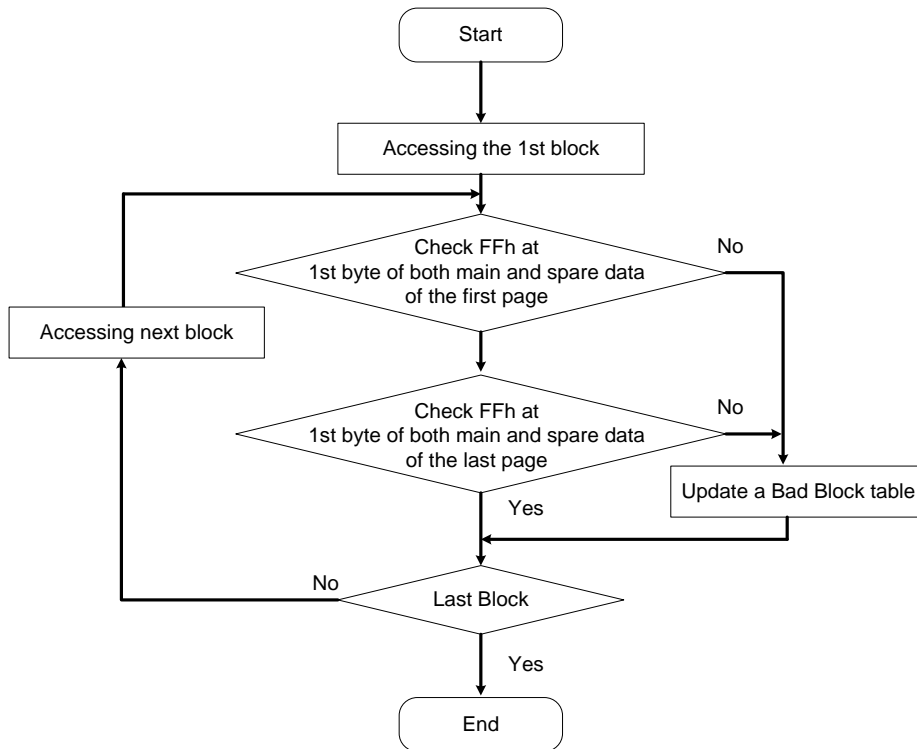

Figure 5-3: Flow Chart To Create Initial Invalid Block Table Figure



## 6. COMMAND SET

Function	1 <sup>st</sup>	2 <sup>nd</sup>	3 <sup>rd</sup>	4 <sup>th</sup>	During busy
Page read	00H	30H	--	--	No
Read for copy-back	00H	35H	--	--	No
Random data output (change column address)	05H	E0H	--	--	No
Cache read start	31H	--	--	--	No
Cache read random	00H	31H	--	--	No
Cache read end	3FH	--	--	--	No
Read ID	90H	--	--	--	No
Read status register	70H	--	--	--	Yes
Read status enhanced (ONFI)	78H				Yes
Page program start / Cache program end	80H	10H	--	--	No
Random data input	85H	--	--	--	No
Copy back program	85H	10H	--	--	No
Cache program start	80H	15H	--	--	No
Block erase	60H	D0H	--	--	No
Reset	FFH	--	--	--	Yes
Read parameter page	ECH	--	--	--	No
Read unique ID	EDH	--	--	--	No
Multi-Plane program	80H	11H	80/81H	10H	No
Multi-Plane copy back program	85H	11H	85H	10H	No
Multi-Plane block erase	60H	60H	D0H		No
Multi-Plane block erase (ONFI)	60H	D1H	60H	D0H	No
Read page two-plane	00H	32H	00H	30H	No
Read for two-plane copy back	00H	32H	00H	35H	No

Note: 1. read status, read ID are always output on IO[7:0].



## 7. BUS OPERATION

The bus on the device is multiplexed. Data I/O, addresses, and commands all share the same pins. I/O [15:8] are used only for data in the x16 configuration. Addresses and commands are always supplied on I/O [7:0].

The command sequence typically consists of a COMMAND LATCH cycle, address input cycles, and one or more data cycles, either READ or WRITE.

There are serial standard bus operations that control the device. These are Command Input, Address Input, Data Input, Data Output, Write Protect, and Standby.

CLE	ALE	CE#	WE#	RE#	WP#	MODE
H	L	L	Rising	H	X	Command input for read mode
L	H	L	Rising	H	X	Address input (5 cycles) for read mode
H	L	L	Rising	H	H	Command input for write mode
L	H	L	Rising	H	H	Address input (5 cycles) for write cycle
L	L	L	Rising	H	H	Data input
L	L	L	H	Falling	X	Sequential read and data output
L	L	L	H	H	X	During read(busy)
X	X	X	X	X	H	During program/Erase(busy)
X	X	X	X	X	L	Write protect
X	X	H	X	X	0V / VCC	Standby

### Notes:

1. X can be VIL or VIH. H = Logic level HIGH. L = Logic level LOW.
2. WP# should be biased to CMOS high or CMOS low for stand-by mode.
3. WE# and RE# during Read Busy must be keep on high to prevent unplanned command/address/data input or to avert unintended data out. In this time, only Reset and Read Status can be input to the device.



### 7.1 Command Input Cycle

Command Input bus operation is used to give a command to the memory device. Commands are accepted with Chip Enable low, Command Latch Enable high, Address Latch Enable low and Read Enable high and latched on the rising edge of Write Enable. Moreover for commands that starts a modify operation (write/erase) the Write Protect pin must be high.

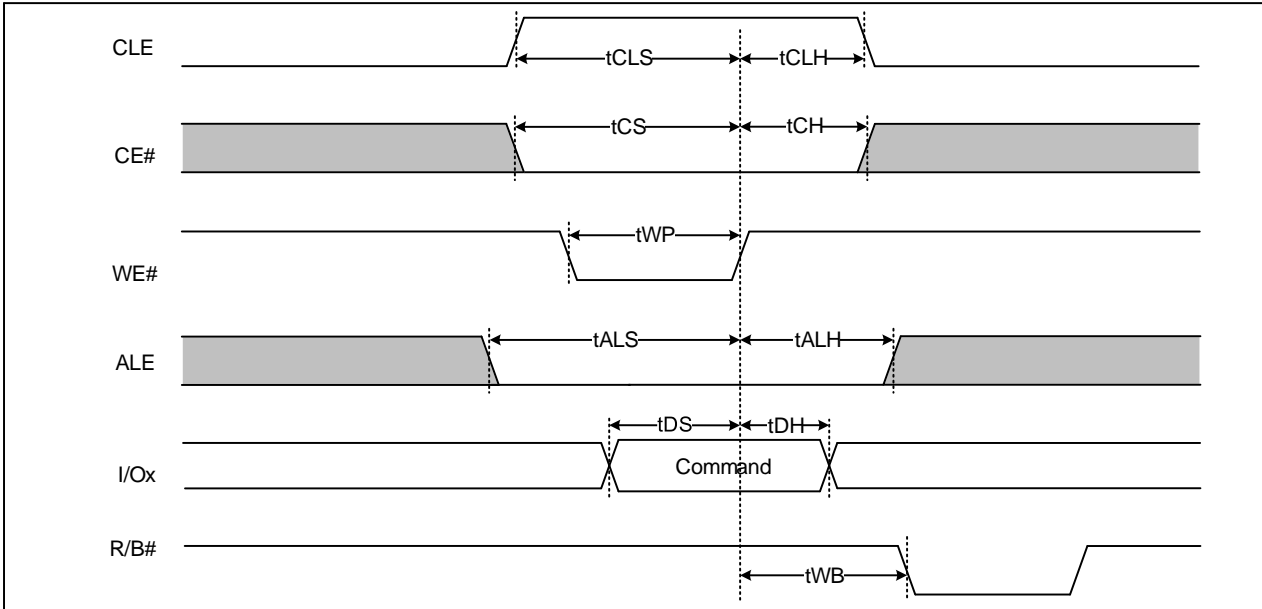

Figure 7-1: Command Input Cycle Figure

### 7.2 Address Input Cycle

Address Input bus operation allows the insertion of the memory address. Addresses are accepted with Chip Enable low, Address Latch Enable high, Command Latch Enable low and Read Enable high and latched on the rising edge of Write Enable. Moreover for commands that starts a modify operation (write/erase) the Write Protect pin must be high.

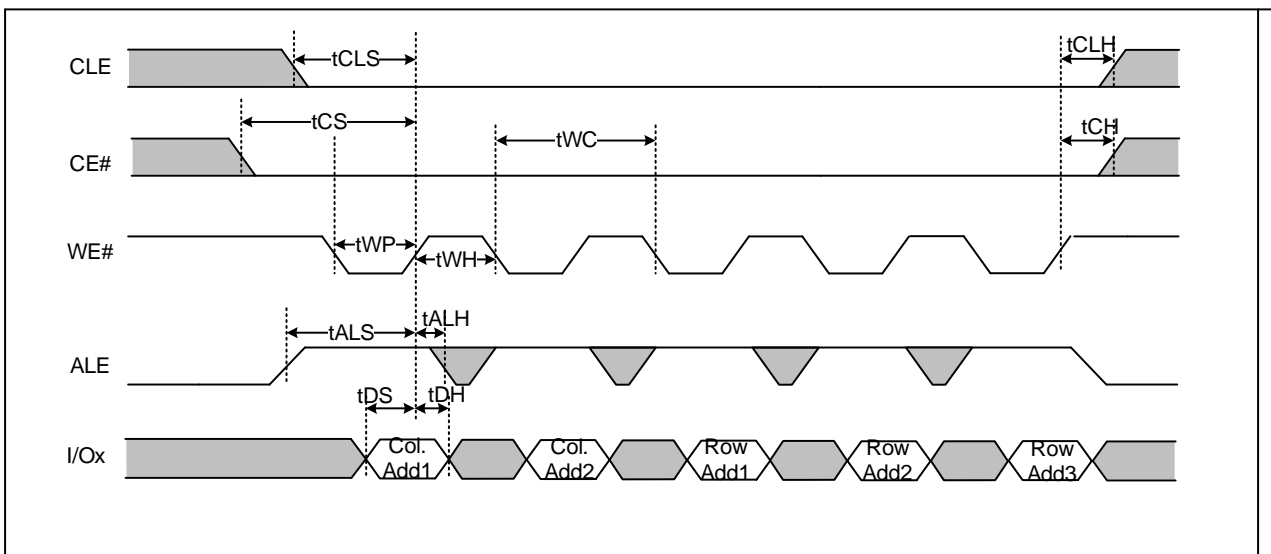

Figure 7-2: Address Input Cycle Figure





### 7.3 Data Input Cycle

Data Input bus operation allows to feed to the device the data to be programmed. The data insertion is serially and timed by the Write Enable cycles. Data are accepted only with Chip Enable low, Address Latch Enable low, Command Latch Enable low, Read Enable high, and Write Protect high and latched on the rising edge of Write Enable.

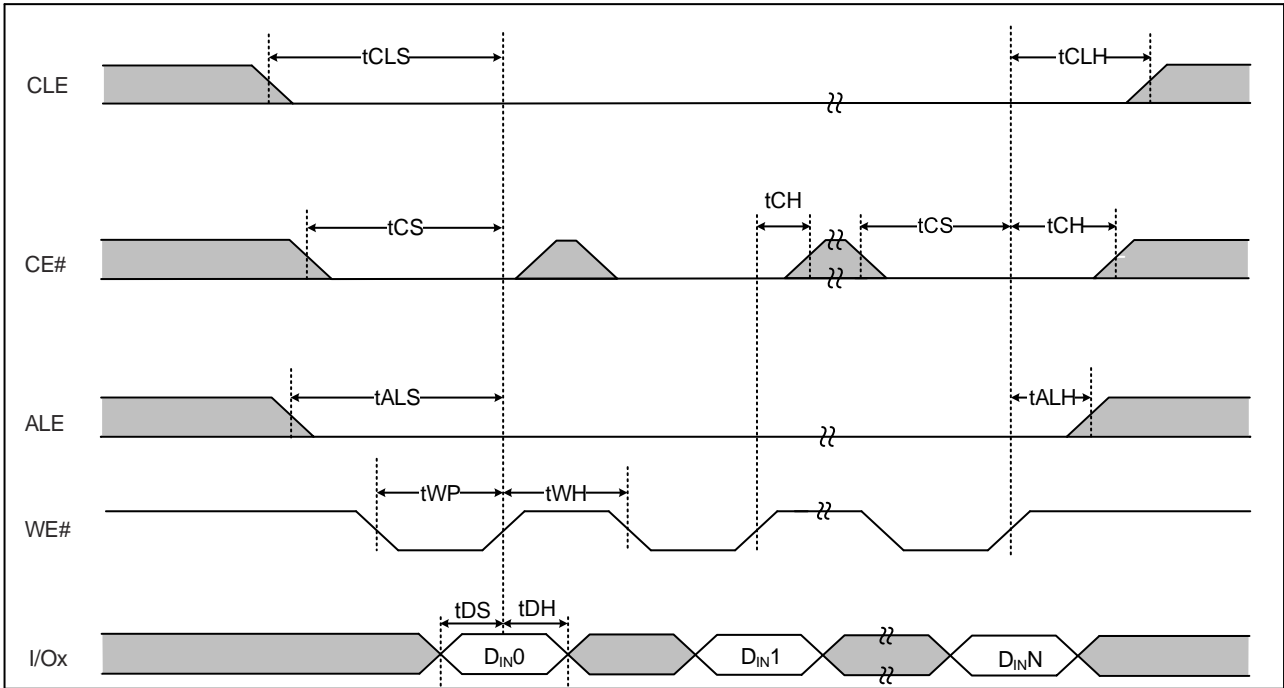

Figure 7-3: Data Input Cycle Figure



### 7.4 Data Output Cycle

Data Output bus operation allows to output data from the device. The data output cycle is serially and timed by the Read Enable cycles. Data output may be used with CE# don't care. However, if CE# don't care is used tCEA and tCOH timing requirements shall be met by the host.

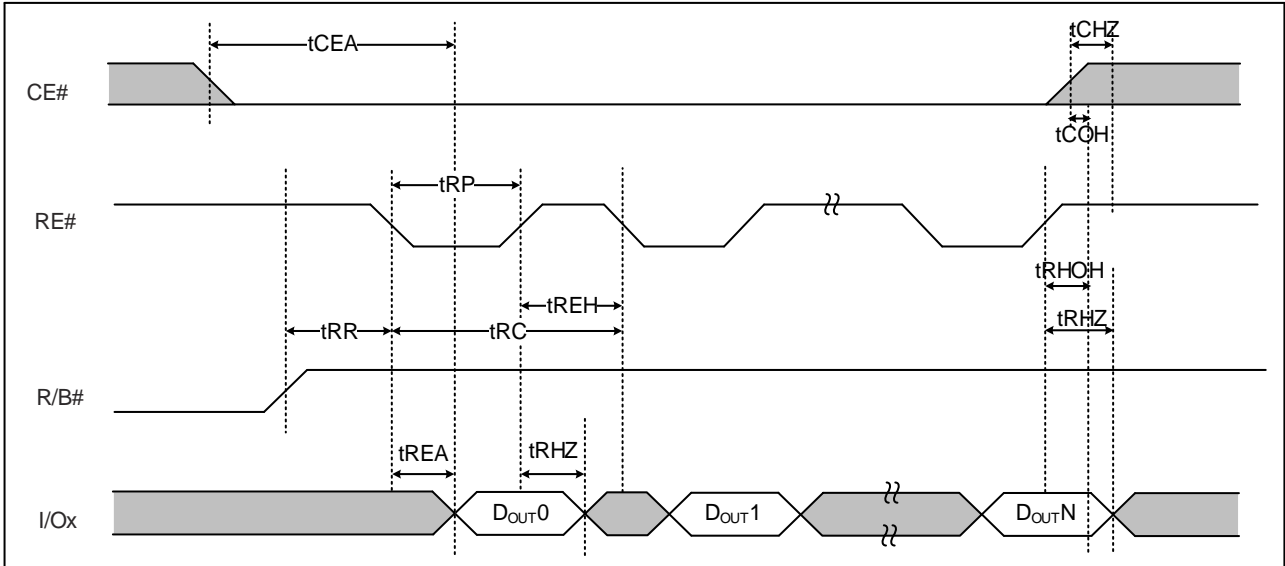

Figure 7-4\_a: Data Output Cycle Figure

If the host side uses a sequential access time (t<sub>RC</sub>) of less than 30ns, the data can be latched on the next falling edge of RE# as the waveform of EDO (Extended data output) mode.

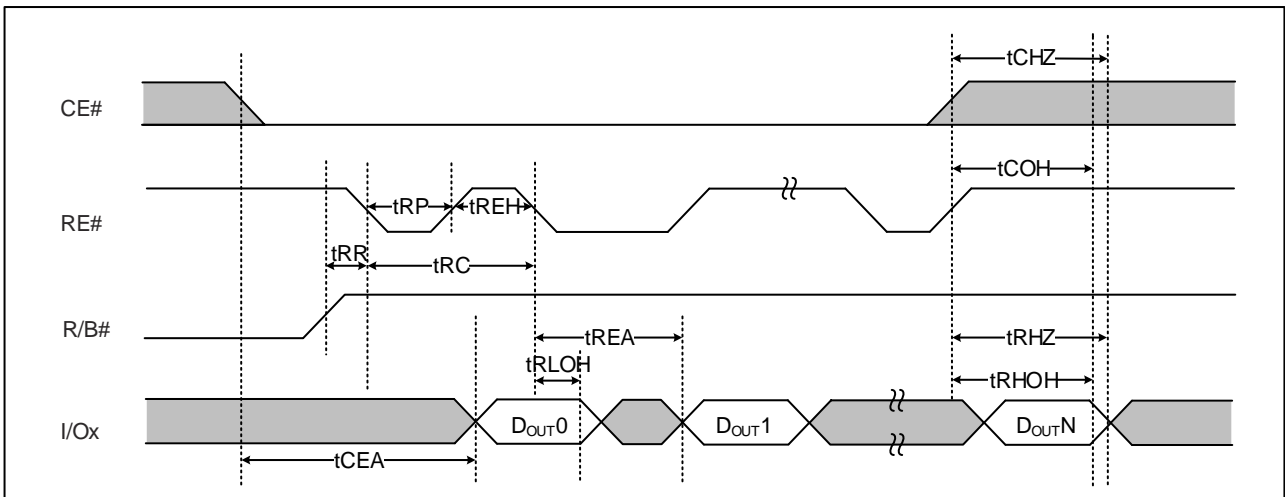

Figure 7-4\_b: Data Output Cycle Figure



### 7.5 Write Protect

The Erase and Program Operations are automatically reset when WP# goes low. The operations are enabled and disabled as follows.

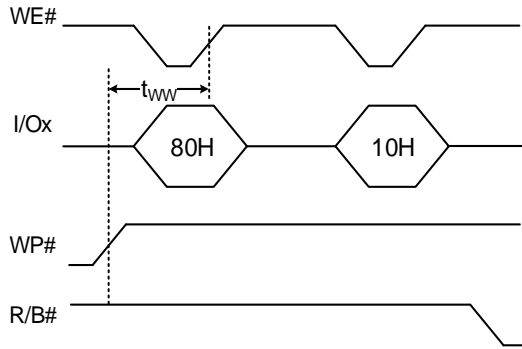

Figure 7-5\_a: Write Protect Disable with program figures

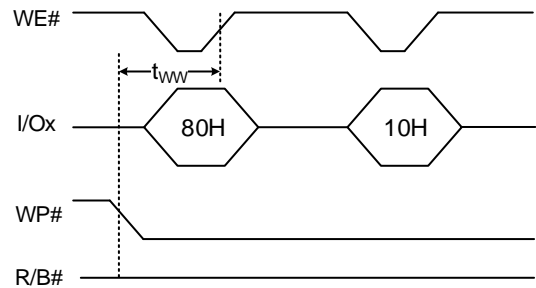

Figure 7-5\_b: Write Protect Enable with program figures

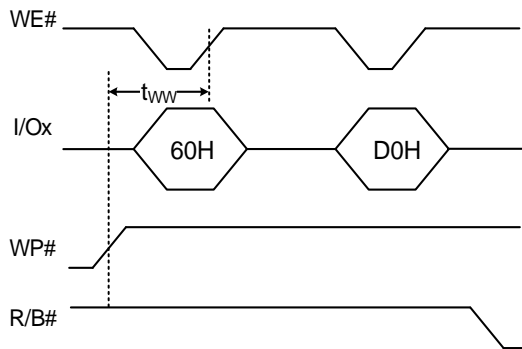

Figure 7-5\_c: Write Protect Disable with erase Figure

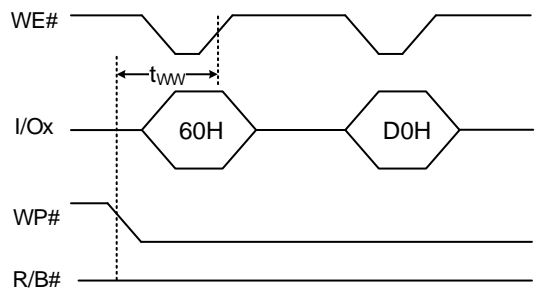

Figure 7-5\_d: Write Protect Enable with erase figures

## 8. OPERATION DESCRIPTION

### 8.1 Page Read Operation

#### 8.1.1 Common Page Read (00H-30H)

Read is initiated by writing 00H-30H to the command register along with five address cycles. After initial power up, the first page of the first block has been read to cache, ready for random read out.

The system controller can detect the completion of this data transfer ( $t_R$ ) by analyzing the output of R/B# pin or read status command. Once the data in a page is loaded into the cache register, they may be read out in  $t_{RC}$  by sequentially toggle RE#. The repetitive high to low transitions of the RE# clock make the device output the data starting from the selected column address up to the last column address.

After the last data has been read out, CE# may be pulled up for some time to end the read operation, while during the RE# toggle cycle, CE# may be don't care when RE# is high. The CE# Don't Care feature may simplify the system interface, which allows controller to directly download the code from flash device, and the CE# transitions will not stop the read operation during the latency time.

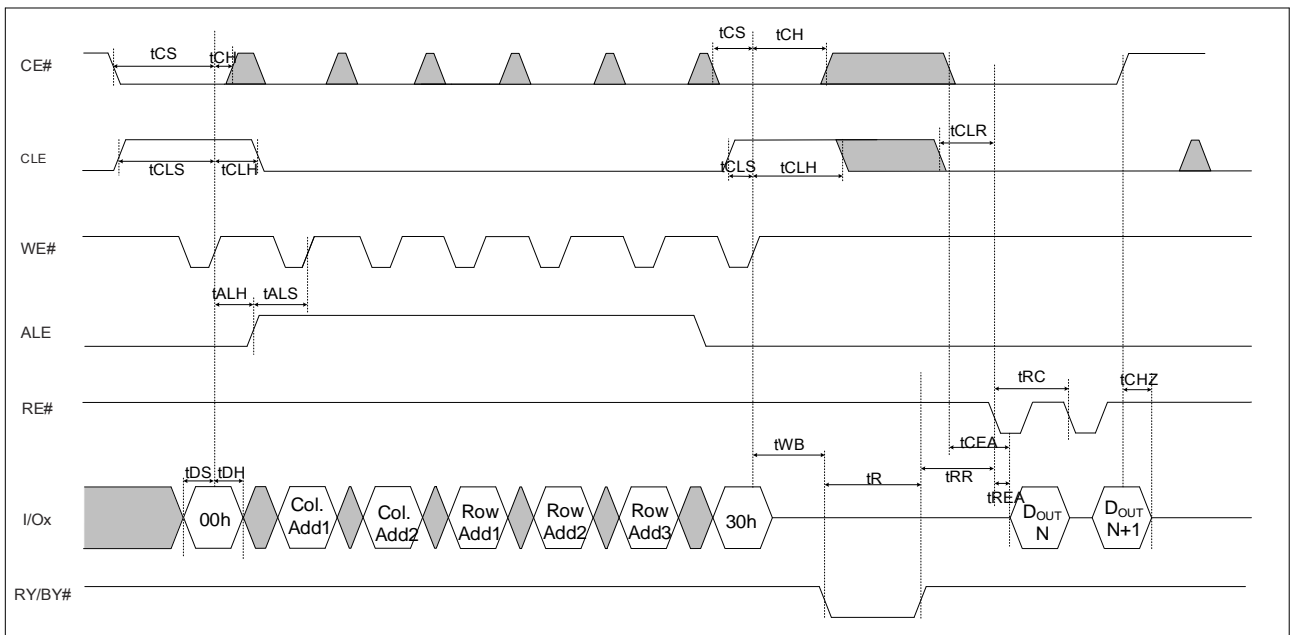

Figure 8-1: Common Page Read Figure



### 8.1.2 Random Data Output (05H-E0H)

The device may output random data in a page instead of the consecutive sequential data by writing random data output command (05H-E0H). The column address of next data, which is going to be out, may be changed to the address which follows random data output command. Random data output can be operated multiple times regardless of how many times it is done in a page. Random data output shall only be issued when the device is in a read idle condition.

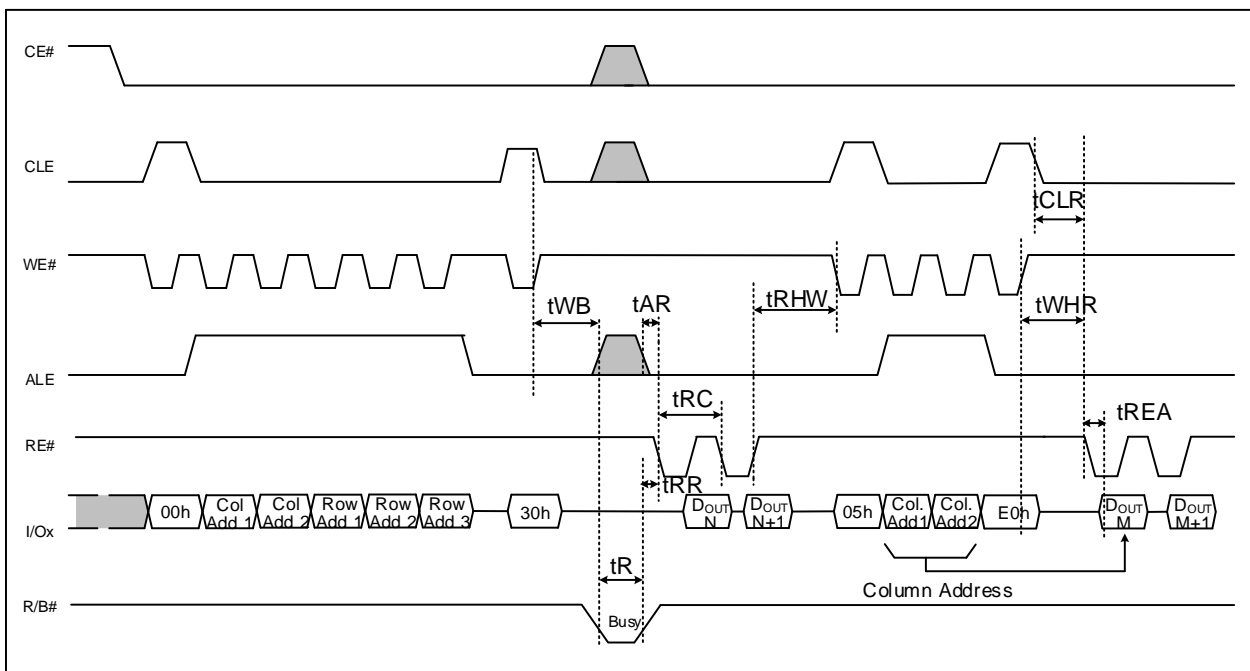

Figure 8-2: Random Data Output Figure

Note: the address followed 05h can be only 2bytes address cycle.

### 8.1.3 Cache Read Sequential (31H/3FH)

The Cache Read function permits a page to be read from the cache register while another page is simultaneously read from the Flash array, and is available only within a block. A Read Page command shall be issued prior to the initial sequential or random Read Cache command in a read cache sequence. A Read Cache command shall be issued prior to a Read Cache End (3FH) command being issued.

The Cache Read function may be issued after the Read function is complete. The host may enter the address of the next page to be read from the Flash array. Data output always begins at column address 00H. If the host does not enter an address to retrieve, the next sequential page is read, when the Read Cache function is issued. After the operation is begun R/B# is set to high (ready) and the host may begin to read the data from the previous Read or Read Cache function. Issuing an additional Read Cache function copies the data most recently read from the array into the cache register. When no more pages are to be read, the final page is copied into the cache register by issuing the 3FH command.

The host may begin to read data from the cache register when R/B# is set to high (ready). When the 31H and 3FH commands are issued, R/B# shall be cleared to low (busy) until the page has finished being copied from the Flash array.

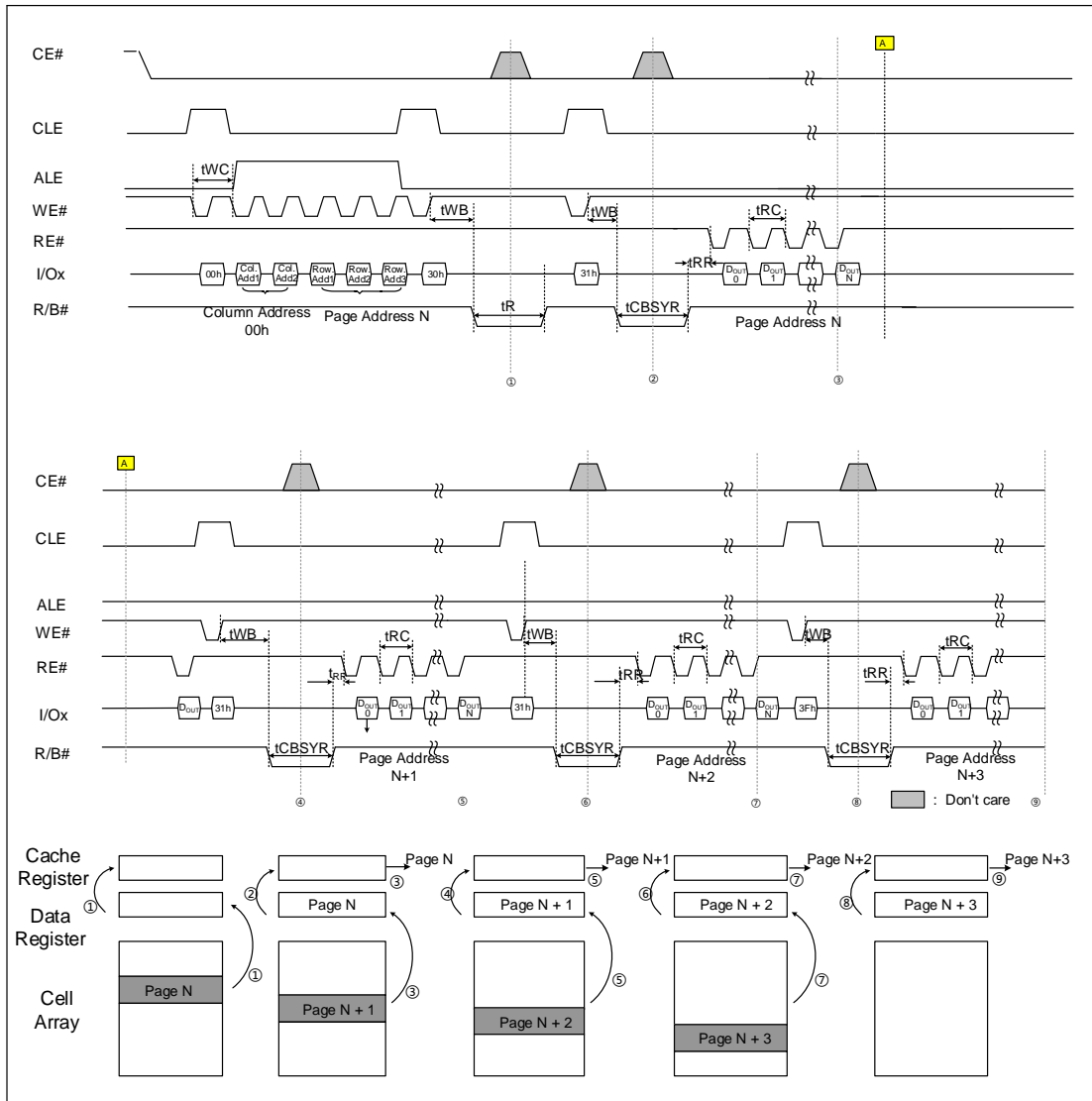

Figure 8-4: Cache Read Sequential Figure

Note:

C1-C2 : Column address of the page to retrieve. C1 is the least significant byte.

R1-R2 : Row address of the page to retrieve. R1 is the least significant byte.

D0-Dn : Data bytes/words read from page requested by the original Read or the previous cache operation.

### 8.1.4 Cache Read Random (00H-31H)

The Cache Read Random operation allows the random page to be read-out with cache operation not just for consecutive page only.

After issuing the 00h command, the column and row address should be given for the start page selection, and followed by the 30h command for address confirmation. The column address is ignored in the cache read random operation. And then, the Cache Read Random operation starts after a latency time  $t_R$  and following a 00h command with the selected page address and following a 31h command, the data can be read-out after the latency time of  $t_{CBSYR}$ . After the previous



selected page data out, a new selected page address can be given by writing the 00h-31h command set again. The Cache Read Random command is available only within a block.

The Random Data Output (05h-E0h) command can be used to change the column address of the data being output from the cache register. When no more pages are to be read, the final page is copied into the cache register by issuing the 3FH command in one block.

The host may begin to read data from the cache register when R/B# is set to high (ready). When the 31H and 3FH commands are issued, R/B# shall be cleared to low (busy) until the page has finished being copied from the Flash array. Status Register can be checked after the Read Status command (70h) is issued. IO6 behaves the same as R/B# pin, IO5 indicates the internal chip operation. "0" means the chip is in internal operation and "1" means the chip is idle. Command 00h should be given to return to the cache read operation.

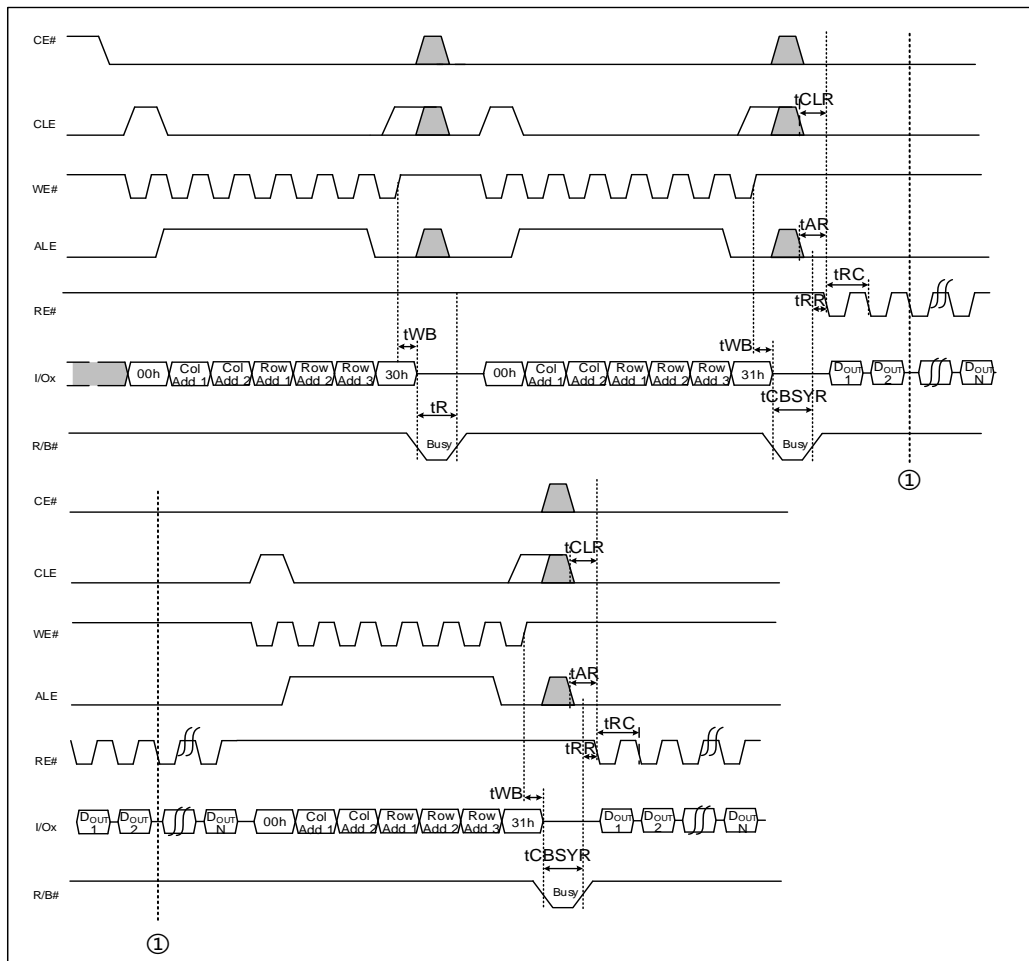

Figure 8-5: Cache Read Random Figure

### 8.1.5 Read for copy back (00H-35H)

The Copy-Back Read is configured to efficiently rewrite data stored in a page without data reloading when no error within the page is found. The data is read out only at cache buffer for copy-back program.

Though it is not required, it is recommended that the host read the data out of the device to verify the data prior to issuing the Copy-Back Program (85h-10h) command to prevent the propagation of data errors.

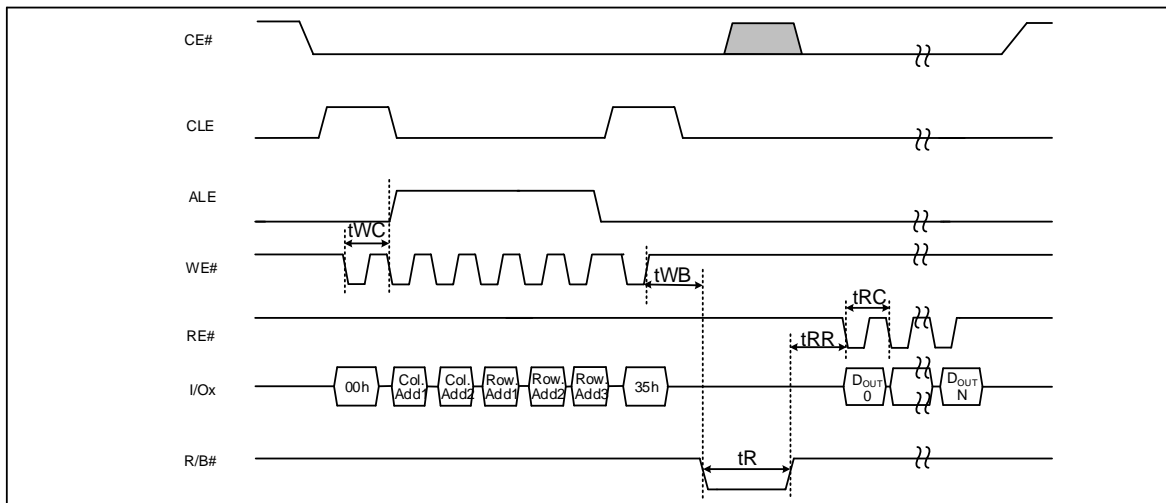

Figure 8-6: Copy-Back Read Figure

### 8.1.6 Read Two Plane (00H-32H-00H-30H)

The Two-Plane Page Read operation is an extension of the Page Read operation. The device supporting Two-plane page read operation also allows multi Random data-output from each plane(i.e. Two-Plane Random Data Output) once multi-pages from each plane are loaded to cache register. With the primary command, R/B returns to ready in a short time (i.e. tDBSY) after the first command 32h since it does not load data from a selected page, and the selected page data of each plane are transferred to the cache registers in less than tR after command 30h. When setting page addresses of each plane, the page addresses shall be identical although block addresses differ.

The Two-plane addresses shall be set in a consecutive manner from a lower address plane to a higher address plane and the same plane address shall not be set twice within a set of address setting sequence for the Two-Plane Page Read Operation. Starting plane address shall be Plane0.

Once the data is loaded into the cache registers, the data on the first plane can be read out by issuing the Two-Plane Random Data Output command. The data on the other plane can be also read out using the identical command sequences. follow figure define Two-plane Page Read and Two-Plane Random Data Output behavior and timings.

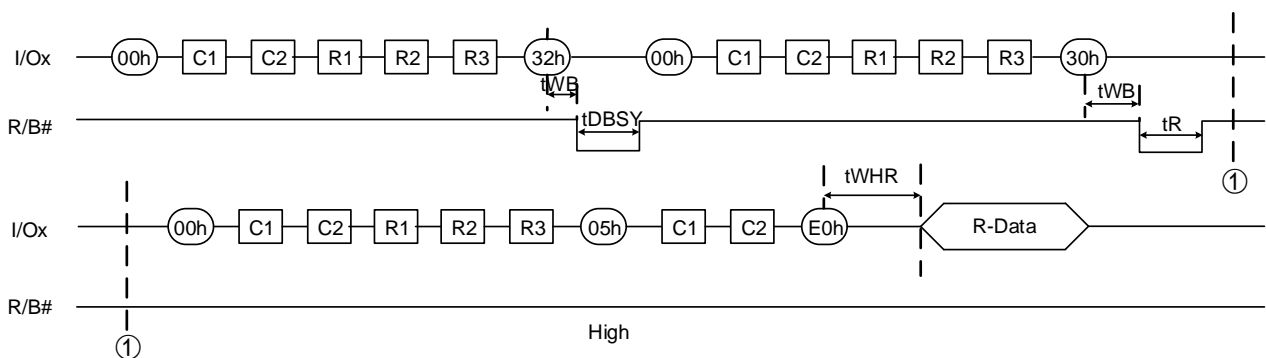

Figure 8-8: Read Two Plane Figure





### 8.1.7 Read for Two-Plane Copy Back (00H-32H-00H-35H)

The Two-Plane Copy-Back Program is an extension of the Copy-back Program. Two-Plane Copy-Back Program operation is executed two sets of commands, Two-Plane Read for Copy-Back and Two-Plane Copy-Back Program. The Two-plane addresses shall be set in a consecutive manner from a lower address plane to a higher address plane and the same plane address shall not be set twice within a set of address setting sequence for the Two-Plane Copy-Back Program Operation. Starting plane address shall be plane0.

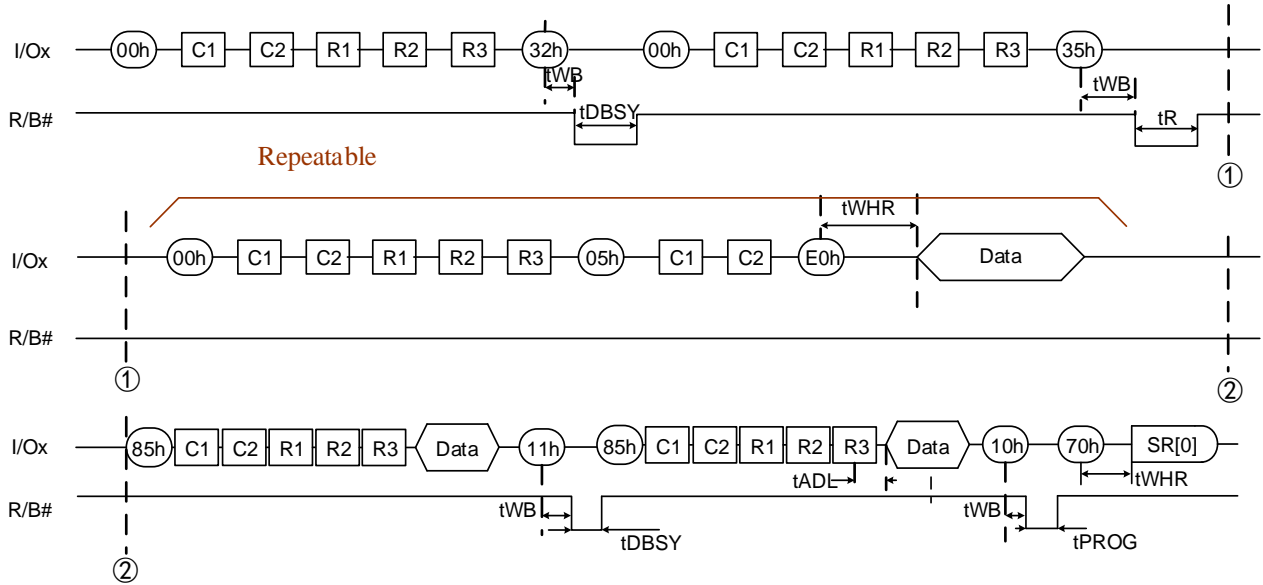

Figure 8-9: Read for Two-Plane Copy Back Figure

Note: the data followed 85h command is optional.



## 8.2 Page Program Operation

### 8.2.1 Common Page Program (80H-10H)

The device is programmed basically on a page basis, but it does allow multiple partial pages programming of a word or consecutive bytes u e. The addressing should be done in sequential order in a block.

A page program cycle consists of a serial data loading period in which up to one page of data may be loaded into the cache register, followed by a non-volatile programming period where the loaded data is programmed into the appropriate cell.

The serial data loading period begins by inputting the Serial Data Input command (80h), followed by the five cycle address inputs and then serial data loading. The words other than those to be programmed do not need to be loaded.

The Page Program Confirm command (10h) initiates the programming process. Writing 10h alone without previously entering the serial data will not initiate the programming process. The internal write state controller automatically executes the algorithms and timings necessary for program and verify, thereby freeing the system controller for other tasks. Once the program process starts, the Read Status command may be issued to read the status register.

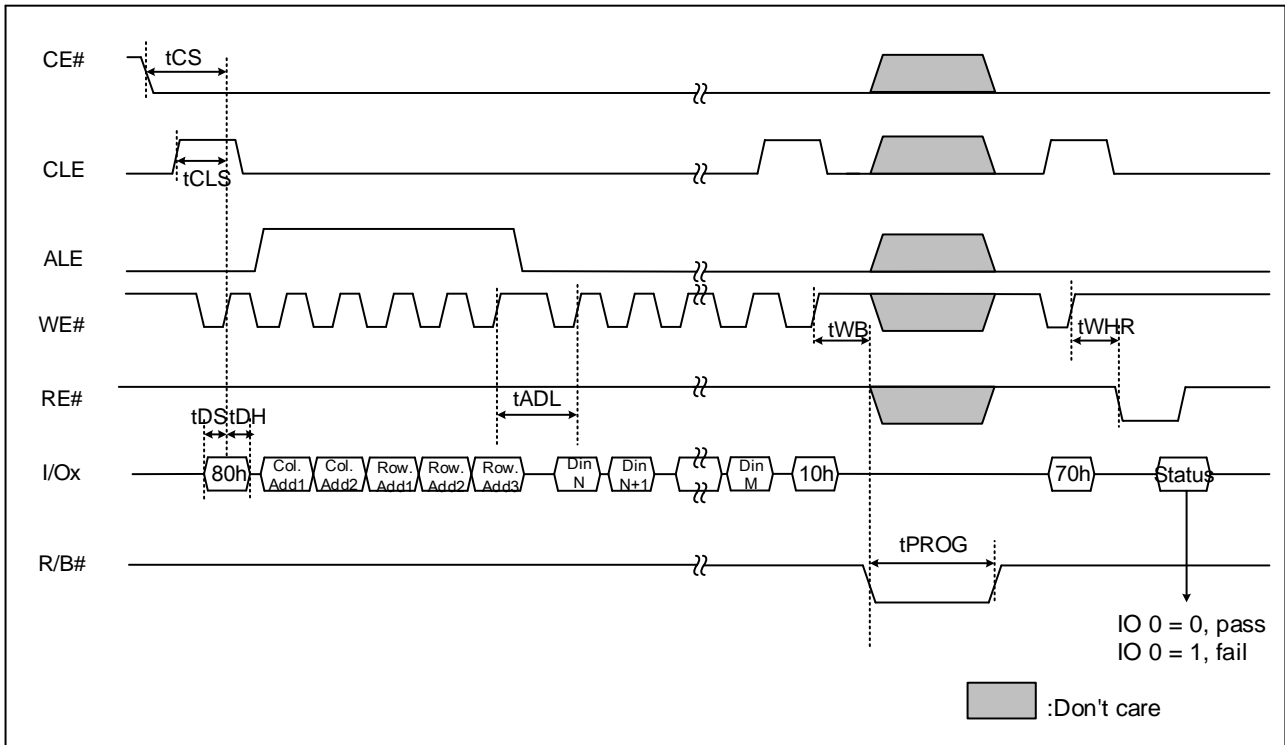

Figure 8-10: Common Page Program Figure



### 8.2.2 Page Program Operation with Random Data Input (85H)

The device supports random data input in a page. The column address of next data, which will be entered, may be changed to the address which follows random data input command (85H). Random data input may be operated multiple times regardless of how many times it is done in a page.

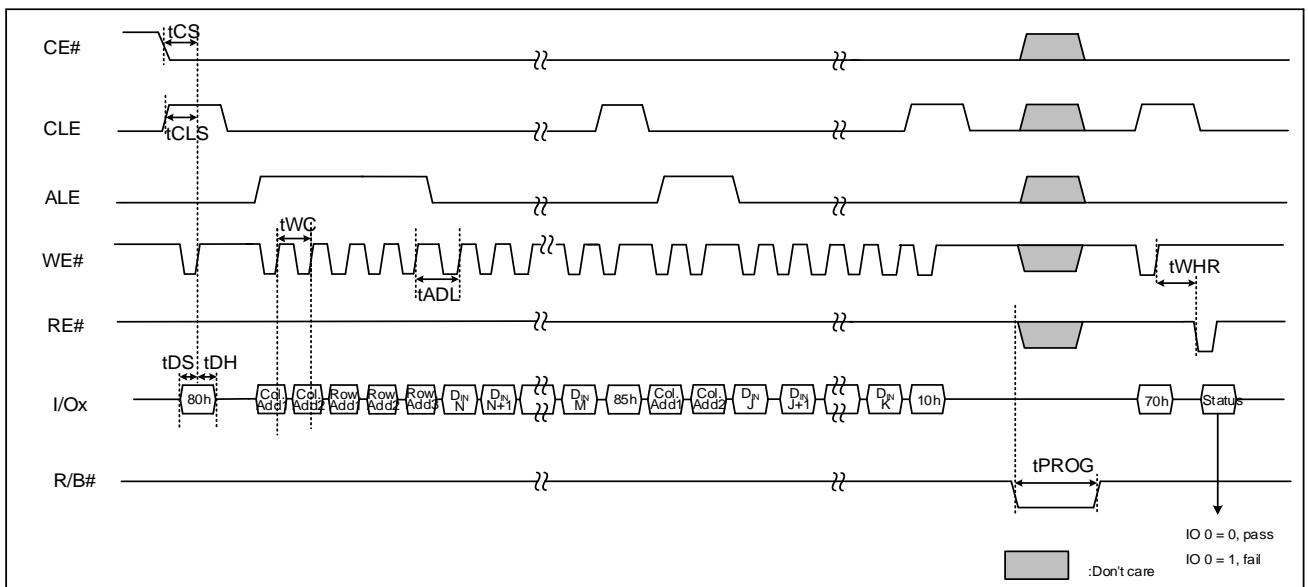
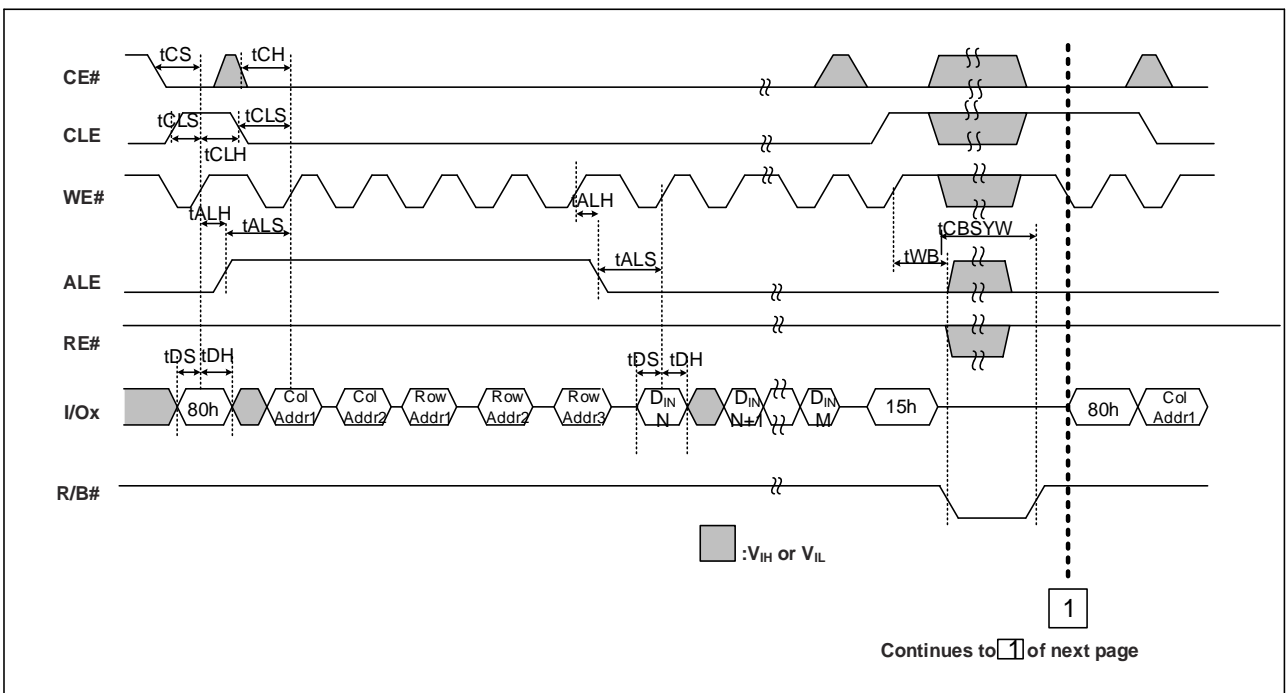

Figure 8-11: Page Program Operation with Random Data Input Figure

### 8.2.3 Cache Program Operation (80H-15H)

Cache Program is an extension of Page Program, which is executed with one cache register and one data register, and is available only within a block. Serial data input may be executed while data stored in data register are programmed into memory cell.

After writing the first set of data up to one page into the selected cache register, Cache Program command (15H) instead of actual Page Program (10H) is inputted to make cache register free and to start internal program operation. To transfer data from cache register to data register, the device remains in Busy state for a short period of time (tCBSYW) and has its cache register ready for the next data-input while the internal programming gets started with the data loaded into data register. Read Status command (70H) may be issued to find out when cache register become ready by polling the Cache-Busy status bit (I/O 6). Pass/fail status of only the previous page is available upon the return to Ready state. When the next set of data is loaded with the Cache Program command, tCBSYW is affected by the progress of pending internal programming. The programming of the cache register is initiated only when the pending program cycle is finished and the data register are available for the transfer of data from cache register. The status bit (I/O5) for internal Ready/Busy may be polled to identify the completion of internal programming. If the system monitors the progress of programming only with R/B#, the last page of the target programming sequence must be programmed with actual Page Program command (10H). If, after tCBSYW, the host wants to wait for the PROGRAM CACHE operation to complete, without issuing the PROGRAM PAGE (80h-10h) command, the host should monitor ARDY until it is 1. The host should then check the status of the FAIL and FAILC bits.



Continues to 1 of next page

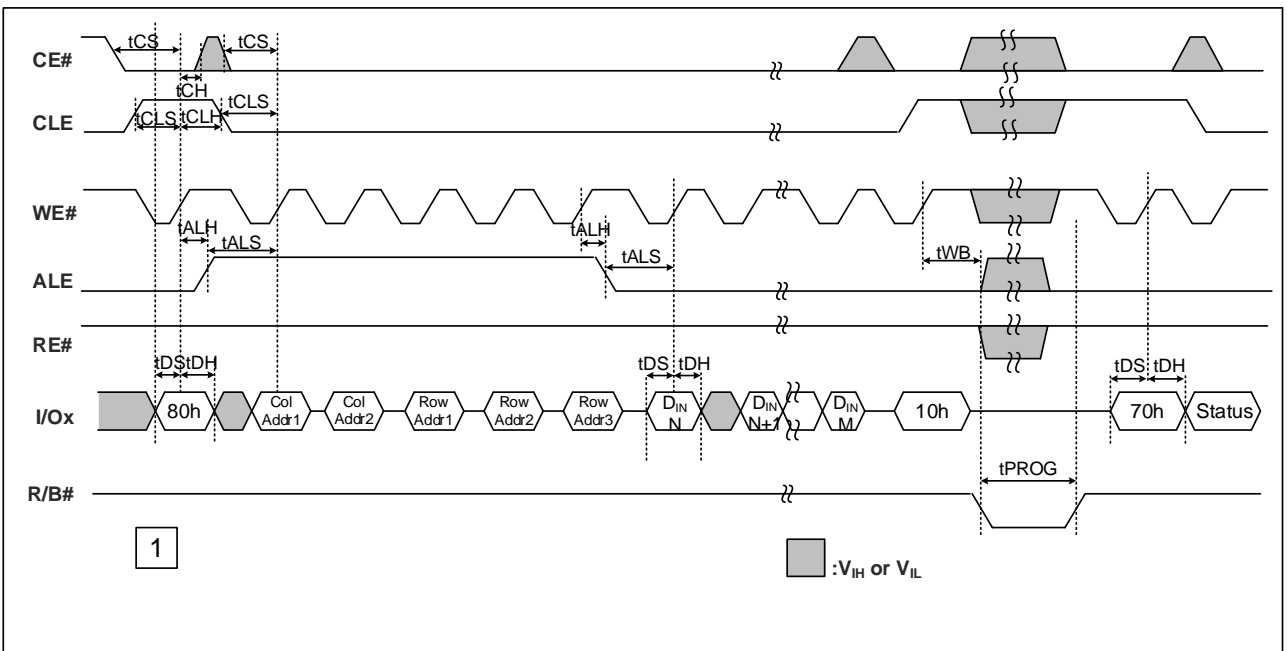

Figure 8-13: Cache Program Operation Figure



### 8.2.4 Copy-Back Program with Random Data Input (85H-10H)

The copy-back program is configured to quickly and efficiently rewrite data stored in one page without utilizing an external memory. Since the time-consuming cycles of serial access and re-loading cycles are removed, the system performance is improved.

The benefit is especially obvious when a part of a block is updated and the rest of the block also needs to be copied to the newly assigned free block.

The operation for performing a copy-back program is a sequential execution of page-read without serial access and copying-program with the address of destination page. A read operation with "35h" command and the address of the source page moves the whole page bytes data into the internal cache register. As soon as the device returns to Ready state, optional data read-out is allowed by toggling RE#, or Copy Back command (85H) with the address cycles of destination page may be written. The Program Confirm command (10H) is required to actually begin the programming operation. Data input cycle for modifying a portion or multiple distant portions of the source page is allowed. When there is a program-failure at Copy-Back operation, error is reported by pass/fail status. But, if Copy-Back operations are accumulated over time, bit error due to charge loss is not checked by external error detection/correction scheme.

Please note that Random Data Input (with/without data) is entered before Program Confirm command (10H) after Random Data output.

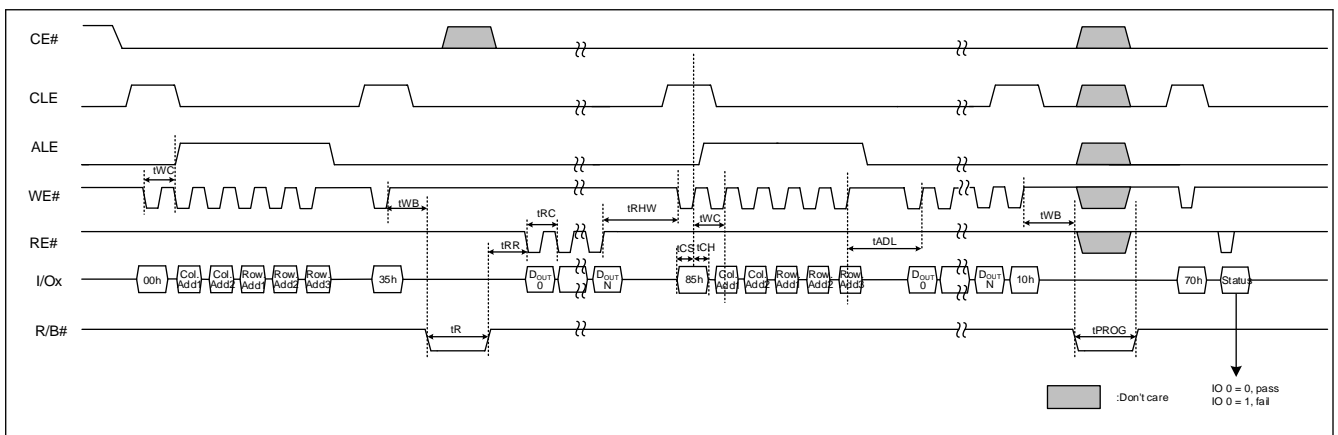

Figure 8-14: Copy-Back Program with Random Data Input Figure

Note: the data followed with 85h command is optional

### 8.2.5 Multi-Plane Program (80H-11H-80/81H-10H)

Device supports multiple plane program: it is possible to program 2 pages in parallel, one per each plane.

A multiple plane program cycle consists of a double serial data loading period in which up to one page data may be loaded into the cache register, followed by a non-volatile programming period where the loaded data is programmed into the memory cell. The serial data loading period begins with inputting the Serial Data Input command (80h), followed by the five cycle address inputs and serial data for the 1st page. The device supports random data input exactly same as in the case of page program operation. The Dummy Page Program Confirm command (11h) stops 1st page data input and devices becomes busy for a short time ( $t_{DBSY}$ ).

Once it has become ready again, either the traditional "81h" or the ONFI "80h" command must be issued, followed by 2nd page address (5 cycles) and its serial data input. Program Confirm command (10h) makes parallel programming of both pages to start. Follow figure describe the sequences.

User can check operation status by monitoring RB# pin or reading status register commands (70h or 78h), as if it were a normal page program: read status register command is also available during Dummy Busy time ( $t_{DBSY}$ ).

In case of fail in any of 1st and 2nd page program, fail bit of status register will be set however, in order to know which page failed, "read status enhanced" command must be issued for further info.

Starting plane address should be Plane0.

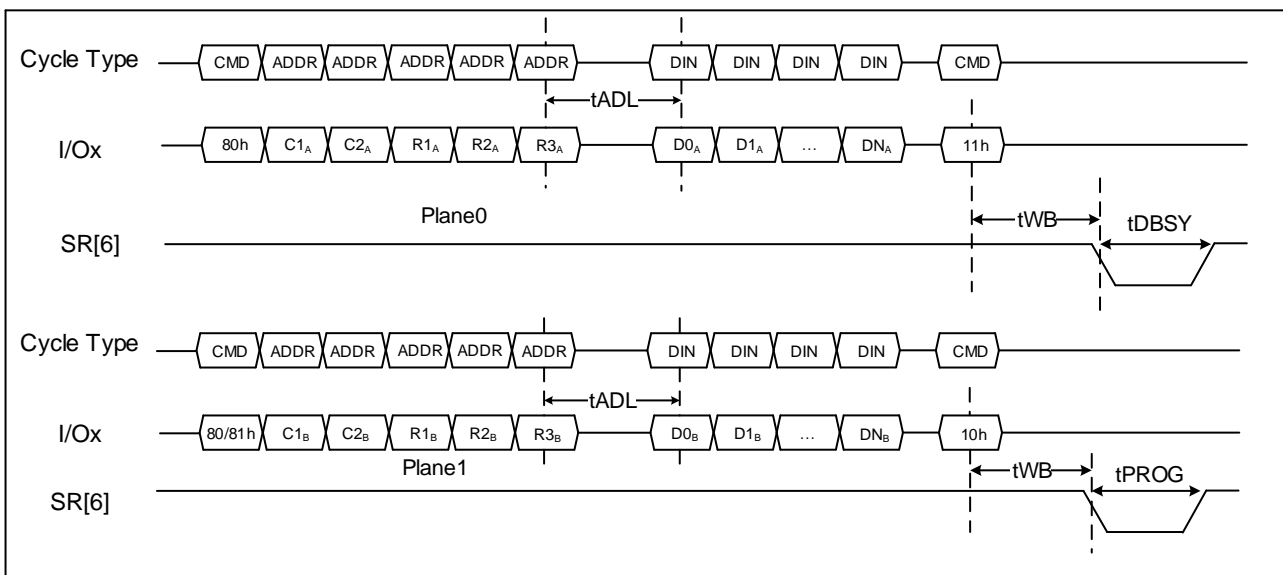

Figure 8-15: Multi-Plane Program Figure

Note: In figure, the 80/81h is compatible traditional/ONFI multi-plane program.



### 8.2.6 Multi-Plane Copy Back Program (85H-11H-85H-10H)

The Two-Plane Copy-Back Program is an extension of the Copy-back Program. As for page program, device supports Multi-plane copy back program with exactly same sequence and limitations. Multi-plane copy back program must be preceded by 2 single page read for copy back command sequences. Starting plane address should be Plane0.

Multi-plane copy back cannot cross plane boundary, the contents of the source page of one device plane can be copied only to a destination page of the same plane.

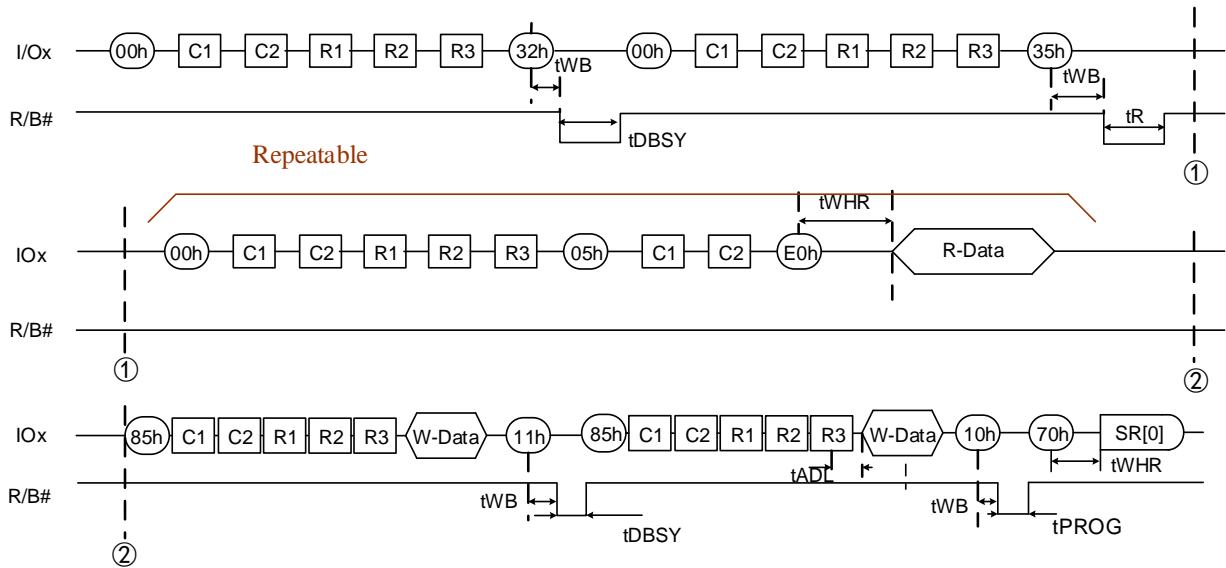

Figure 8-16: Multi-Plane Copy Back Program Figure

Note: the data followed with 85h command is optional.



### 8.3 Block Erase Operation

#### 8.3.1 Common Block Erase Operation (60H-D0H)

The Erase operation is done on a block basis. Block address loading is accomplished in three cycles initiated by an Erase Setup command (60H). Row Address is valid while Column Addresses ignored. The Erase Confirm command (D0H) following the block address loading initiates the internal erasing process. At the rising edge of WE# after the erase confirm command input, the NAND device handles erase operation. Once the erase process starts, the Read Status Register command may be entered to read the status register. The system controller can detect the completion of an erase by monitoring the R/B output, or the Status bit (I/O6) of the Status Register. Only the Read Status command and Reset command are valid while erasing is in progress. When the erase operation is completed, the Write Status Bit (I/O0) may be checked.

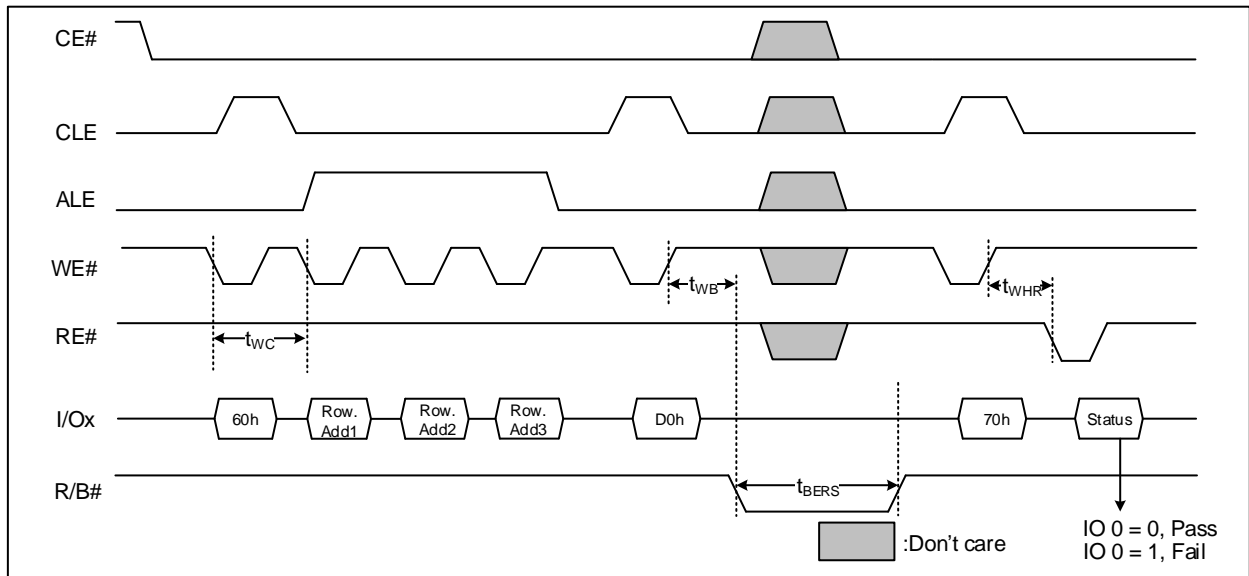

Figure 8-17: Common Block Erase Operation Figure





### 8.3.2 Multi-Plane Block Erase Operation (60H-60H-D0H)

Multi-plane Block Erase allows the erase of two blocks in parallel, one block per memory plane.

The Block erase setup command (60h) must be repeated two times, followed by 1st and 2nd block address respectively (3 cycles each). As for block erase, D0h command makes embedded operation start. In this case, multi-plane erase does not need any Dummy Busy Time between 1st and 2nd block insertion and should obey the multi-plane operation rule.

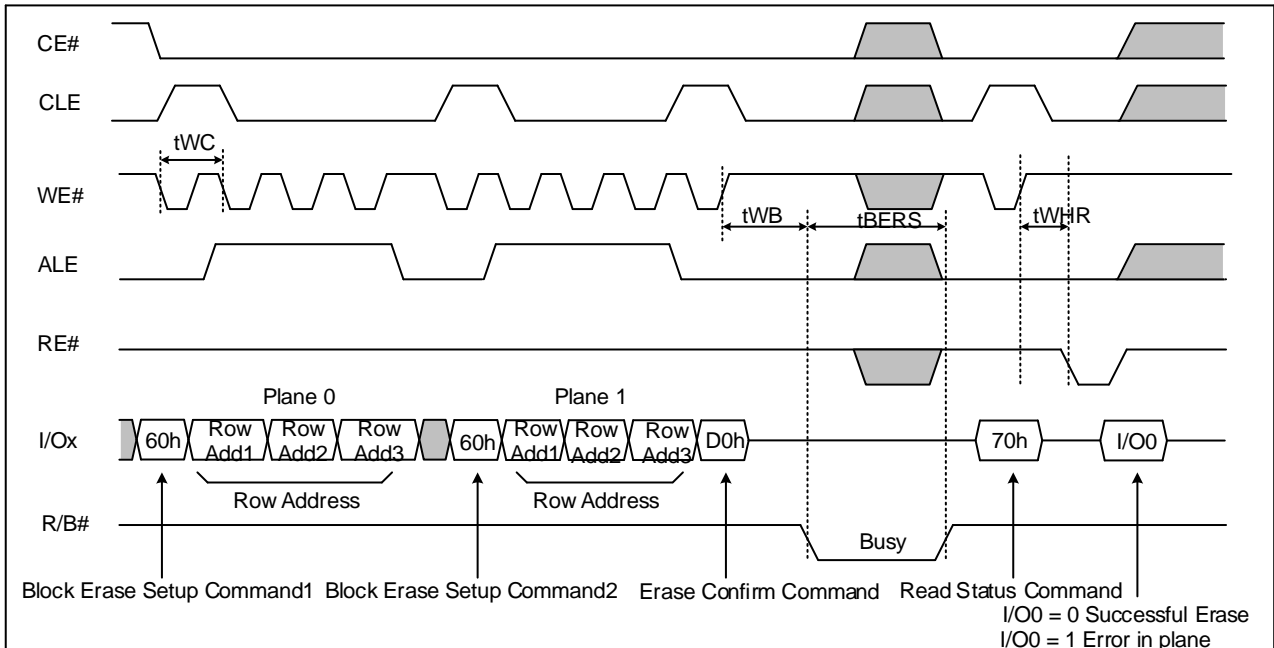

Figure 8-18: Multi-Plane Block Erase Operation Figure

### 8.3.3 Multi-Plane Block Erase Operation-ONFI (60H-D1H)

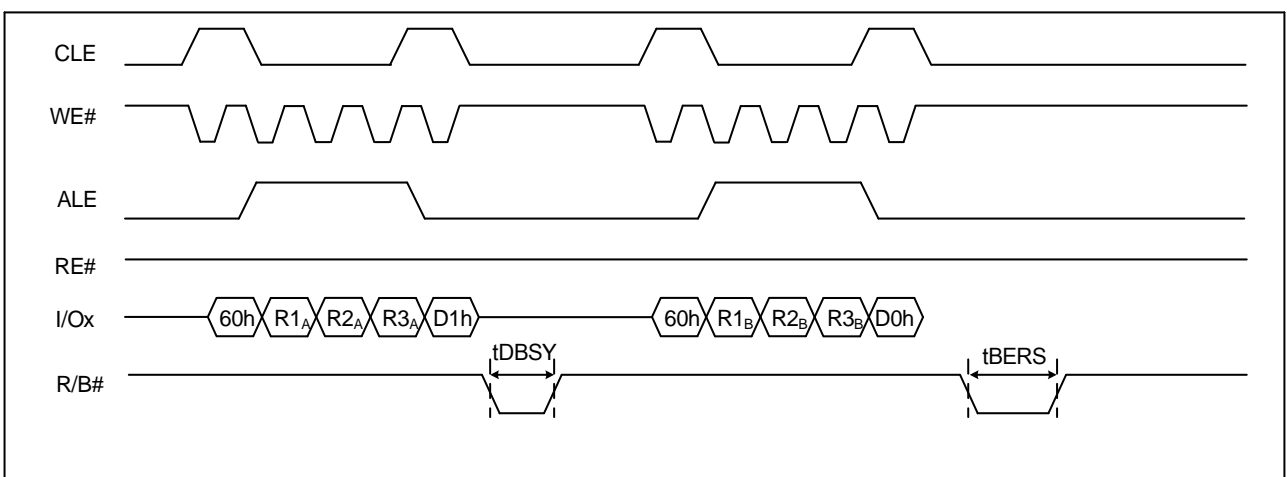

Figure 8-19: Multi-plane Block Erase Operation-ONFI Figure



## 8.4 Reset

### 8.4.1 Reset (FFH)

The device offers a reset feature, executed by writing FFH to the command register. When the device is in busy state during random read, program or erase mode, the reset operation will abort these operations. The contents of memory cells being altered are no longer valid, as the data will be partially programmed or erased. The command register is cleared to wait for the next command, and the Status Register is cleared to value E0h when R/B# is high. If the device is already in reset state a new reset command will be accepted by the command register. The R/B# pin transitions to low for tRST after the Reset command is written.

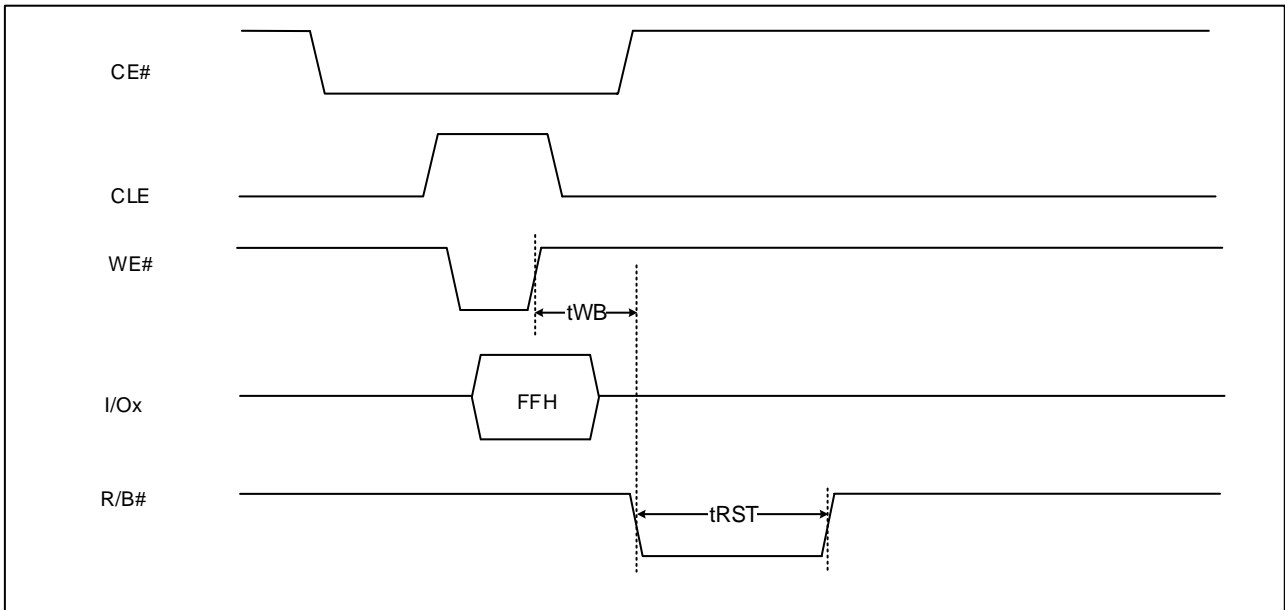

Figure 8-20: Reset (FFH) Figure



## 8.5 Read Device Information

### 8.5.1 Read ID and ONFI Signature (90H)

The device contains a product identification mode, initiated by writing 90H to the command register, followed by an address input of 00H. Five read cycles sequentially output the manufacturer code, and the device code and other information, respectively. The command register remains in Read ID mode until further commands are issued to.

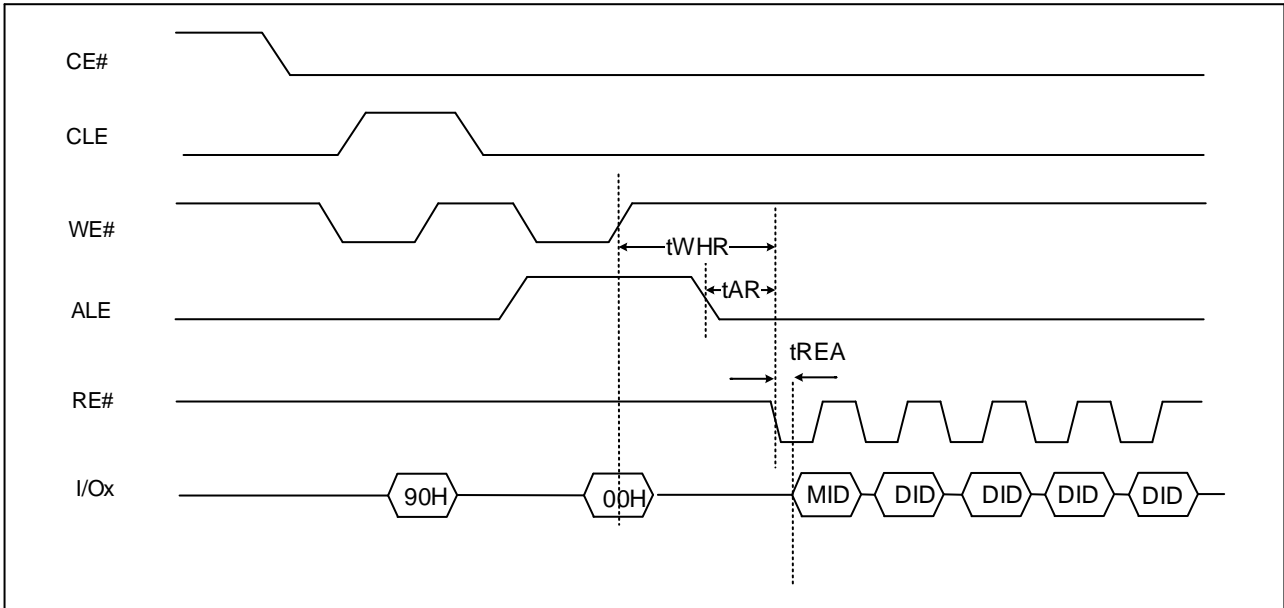

Figure 8-21: Read ID Figure

**ID Definition Table**

Byte	Description
1 <sup>st</sup> Byte	Manufacturer Code (MID)
2 <sup>nd</sup> Byte	Device Code (DID)
3 <sup>rd</sup> Byte	Internal Chip Number, Cell Type, Number of Simultaneously Programmed Pages, Interleaved Program, Write Cache
4 <sup>th</sup> Byte	Page size, Block size, Spare size, Organization
5 <sup>th</sup> Byte	ECC & Plane

**Read ID Data Table**

Part Number	VCC	Bus Width	MID(1 <sup>st</sup> )	DID(2 <sup>nd</sup> )	3 <sup>rd</sup>	4 <sup>th</sup>	5 <sup>th</sup>
GD9FU4G8F4B	3.3v	x8	C8H	DCH	90H	A6H	57H
GD9FU4G6F4B	3.3v	x16	C8H	CCH	90H	E6H	57H
GD9FS4G8F4B	1.8v	x8	C8H	ACH	90H	A6H	57H
GD9FS4G6F4B	1.8v	x16	C8H	BCH	90H	E6H	57H
GD9FU8G8E4B	3.3v	x8	C8H	D3H	91H	A6H	57H
GD9FU8G6E4B	3.3v	x16	C8H	C3H	91H	E6H	57H
GD9FS8G8E4B	1.8v	x8	C8H	A3H	91H	A6H	57H
GD9FS8G6E4B	1.8v	x16	C8H	B3H	91H	E6H	57H



**3<sup>rd</sup> Byte of Device Identifier Description**

3 <sup>rd</sup> Cycle	Description	IO7	IO6	IO5	IO4	IO3	IO2	IO1	IO0
Internal Chip Number	1							0	0
	2							0	1
	4							1	0
	8							1	1
Cell Type	2 Level Cell					0	0		
	4 Level Cell					0	1		
	8 Level Cell					1	0		
	16 Level Cell					1	1		
Number of Simultaneously Programmed Pages	1			0	0				
	2			0	1				
	4			1	0				
	8			1	1				
Interleaved Program Between Multiple Die	Not Supported		0						
	Supported		1						
Write Cache (Cache Programming)	Not Supported	0							
	Supported	1							

**4<sup>th</sup> Byte of Device Identifier Description**

4 <sup>th</sup> Cycle	Description	IO7	IO6	IO5	IO4	IO3	IO2	IO1	IO0
Page Size (without Spare Area)	1KB							0	0
	2KB							0	1
	4KB							1	0
	8KB							1	1
Size of spare area (byte per 512-byte)	32						1		
Reserved		1				0			
Block Size (Without Spare Area)	64KB			0	0				
	128KB			0	1				
	256KB			1	0				
	512KB			1	1				
Organization	x8		0						
	x16		1						



5<sup>th</sup> Byte of ECC & Plane

5 <sup>th</sup> Cycle	Description	IO7	IO6	IO5	IO4	IO3	IO2	IO1	IO0
ECC Level	1bit/512byte							0	0
	2bit/512byte							0	1
	4bit/512byte							1	0
	8bit/512byte							1	1
Plane Number	1					0	0		
	2					0	1		
	4					1	0		
	8					1	1		
Reserved			1	0	1				
Internal ECC	ECC disabled	0							
	ECC enabled	1							

To retrieve the ONFI signature, the command 90H together with an address of 20H shall be entered. The ONFI signature is the ASCII encoding of 'ONFI' where 'O' = 4FH, 'N' = 4EH, 'F' = 46H, and 'I' = 49H. Reading beyond four bytes yields indeterminate values.

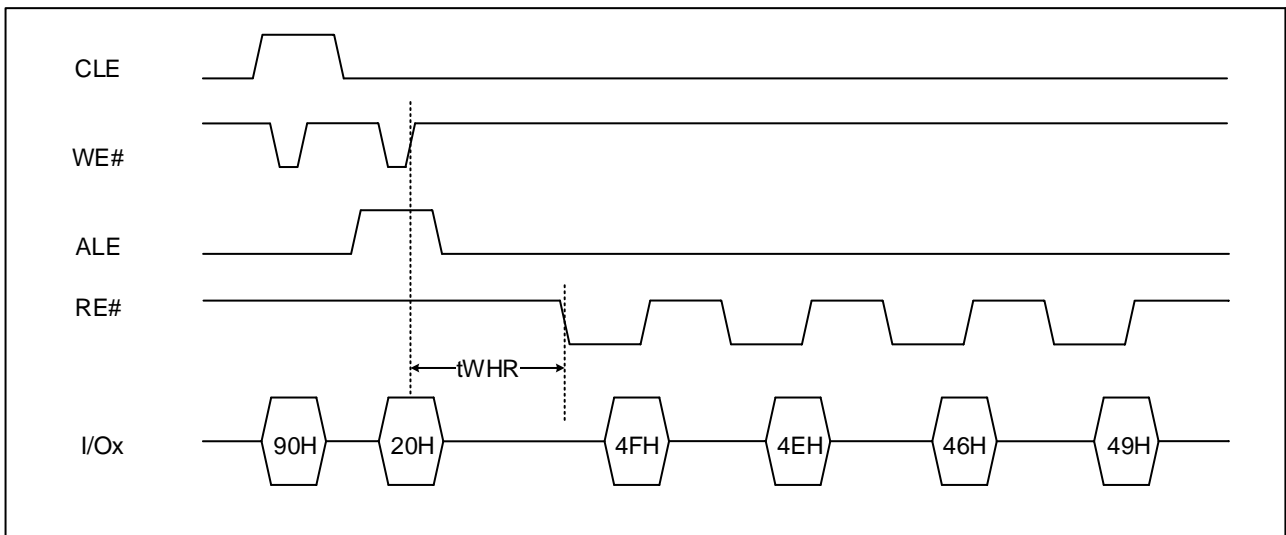

Figure 8-22: Read ONFI Signature Figure



### 8.5.2 Read Unique ID (EDH)

The Read Unique ID function is used to retrieve the 16 byte unique ID (UID) for the device. The unique ID when combined with the device manufacturer shall be unique.

The UID data may be stored within the Flash array. To allow the host to determine if the UID is without bit errors, the UID is returned with its complement. If the XOR of the UID and its bit-wise complement is all ones, then the UID is valid. To accommodate robust retrieval of the UID in the case of bit errors, sixteen copies of the UID and the corresponding complement shall be stored by the target. For example, reading bytes 32-63 returns to the host another copy of the UID and its complement.

To change the data output location, it is recommended to use the Random Data Out command set (05H-E0H). The Status Read command (70H) can be used to check the completion. To continue the read operation, a following read command (00h) to re-enable the data out is necessary.

Bytes	Value
0-15	UID
16-31	UID complement (bit-wise)

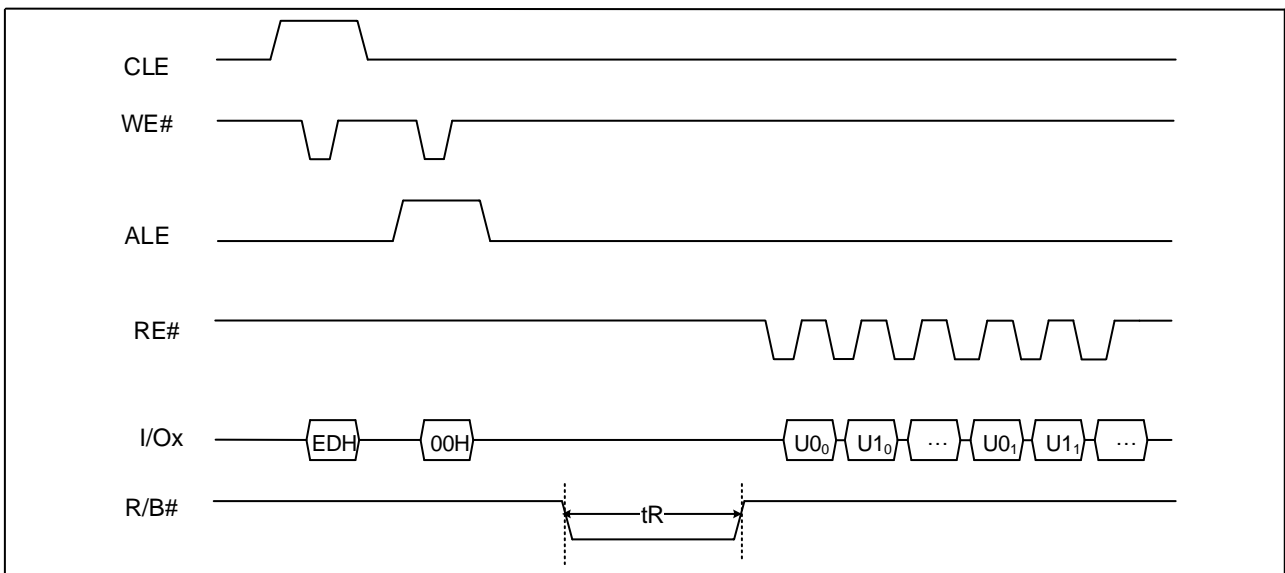

Figure 8-23: Read Unique ID Figure



### 8.5.3 Read Parameter Page (ECH)

The Read Parameter Page function retrieves the data structure that describes the chip's organization, features, timing and other behavioral parameters. This data structure enables the host processor to automatically recognize the NAND Flash configuration of a device. A minimum of three copies of the parameter page are stored in the device. The Read Status command (70H) may be used to check the status of read parameter page during execution. After completion of the Read Status command, 00H is issued by the host on the command line to continue with the data output flow for the Read Parameter Page command.

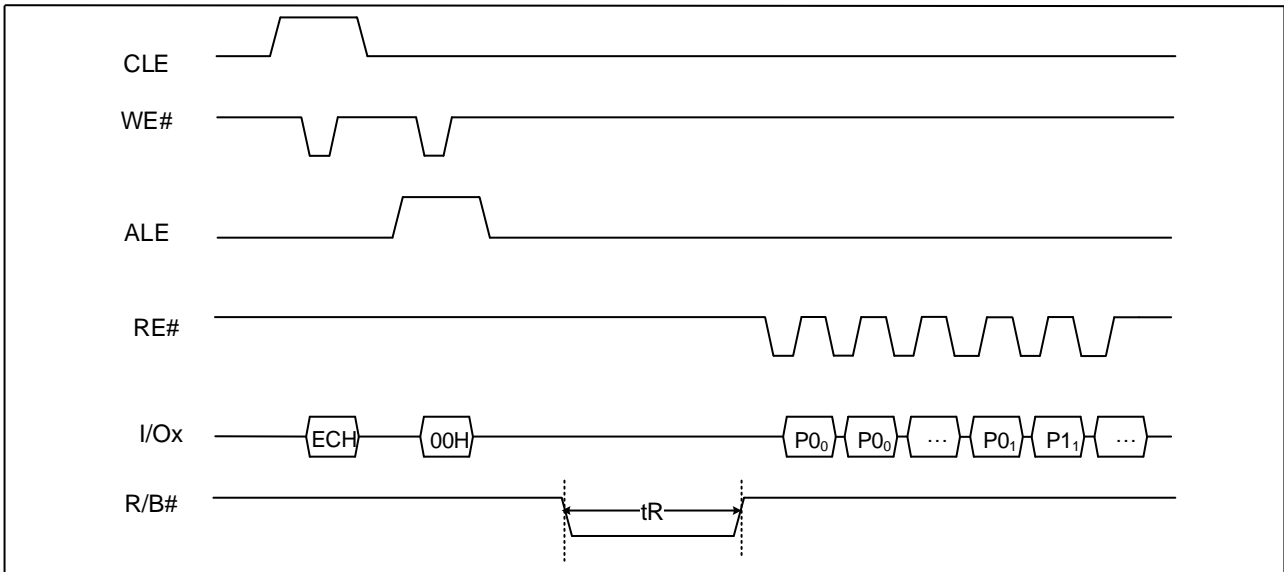

Figure 8-24: Read Parameter Page Figure





Byte	O/M	Description	4Gb	8Gb
0-3	M	Parameter page signature Byte 0: 4FH, "O" Byte 1: 4EH, "N" Byte 2: 46H, "F" Byte 3: 49H, "I"	4FH 4EH 46H 49H	
4-5	M	Revision number 2-15 Reserved (0) 1 1 = supports ONFI version 1.0 0 Reserved (0)	02H 00H	
6-7	M	Features supported 5-15 Reserved (0) 4 1 = supports odd to even page Copy-back 3 1 = supports interleaved operations 2 1 = supports non-sequential page programming 1 1 = supports multiple LUN operations 0 1 = supports 16-bit data bus width	18H(X8)/ 19H(X16) 00H	
8-9	M	Optional commands supported 6-15 Reserved (0) 5 1 = supports Read Unique ID 4 1 = supports Copy-back 3 1 = supports Read Status Enhanced 2 1 = supports Get Features and Set Features 1 1 = supports Read Cache Integrity 0 1 = supports Page Cache Program command	3BH 00H	
10-31		Reserved (0)	00H ... 00H	
		Manufacturer Information block		
32-43	M	Device manufacturer (12 ASCII characters)"GIGADEVICE "	47H 49H 47H 41H 44H 45H 56H 49H 43H 45H 20H 20H	



44-63	M	Device model (20 ASCII characters)	47H	47H		
		<b>Device Model</b>	<b>ORGANIZATION</b>	<b>VCC RANGE</b>	44H	44H
		GD9FS4G8F4B	512M x 8bit	1.7v ~ 1.95v	39H	39H
		GD9FS4G6F4B	256M x 16bit	1.7v ~ 1.95v	46H	46H
		GD9FU4G8F4B	512M x 8bit	2.7v ~ 3.6v	53H/55H	53H/55H
		GD9FU4G6F4B	256M x 16bit	2.7v ~ 3.6v	34H	38H
		<b>Device Model</b>	<b>ORGANIZATION</b>	<b>VCC RANGE</b>	47H	47H
		GD9FS8G8E4B	1G x 8bit	1.7v ~ 1.95v	38H/36H	38H/36H
		GD9FS8G6E4B	512M x 16bit	1.7v ~ 1.95v	46H	45H
		GD9FU8G8E4B	1G x 8bit	2.7v ~ 3.6v	34H	34H
		GD9FU8G6E4B	512M x 16bit	2.7v ~ 3.6v	42H	42H
					20H	20H
					20H	20H
					20H	20H
64	M	JEDEC manufacturer ID"C8"	C8H			
65-66	O	Date code	00H			
			00H			
67-69		Reserved	00H			
			00H			
			00H			
		Memory organization block				
80-83	M	Number of data bytes per page	00H			
			10H			
			00H			
			00H			
84-85	M	Number of spare bytes per page	00H			
			01H			
86-89	M	Number of data bytes per partial page	00H			
			04H			
			00H			
			00H			
90-91	M	Number of spare bytes per partial page	40H			
			00H			
92-95	M	Number of pages per block	40H			
			00H			
			00H			
			00H			



96-99	M	Number of blocks per logical unit (LUN)	00H 08H 00H 00H
100	M	Number of logical units (LUNs)	01H      02H
101	M	Number of address cycles 4-7 Column address cycles 0-3 Row address cycles	23H
102	M	Number of bits per cell	01H
103-104	M	Bad blocks maximum per LUN	28H 00H
105-106	M	Block endurance	05H 04H
107	M	Guaranteed valid blocks at beginning of target	01H
108-109	M	Block endurance for guaranteed valid blocks	00H 00H
110	M	Number of programs per page	04H
111	M	Partial programming attributes 5-7 Reserved 4 1 = partial page layout is partial page data followed by partial page spare 1-3 Reserved 0 1 = partial page programming has constraints	00H
112	M	Number of bits ECC correct ability	08H
113	M	Number of interleaved address bits 4-7 Reserved (0) 0-3 Number of interleaved address bits	00H
114	O	Interleaved operation attributes 4-7 Reserved (0) 3 Address restrictions for program cache 2 1 = program cache supported 1 1 = no block address restrictions 0 Overlapped / concurrent interleaving support	00H
115-127		Reserved	00H ... 00H
		Electrical parameters block	
128	M	I/O capacitance	0AH      14H



129-130	M	Timing mode support 6-1 5Reserved (0) 5 1 = supports timing mode 5 4 1 = supports timing mode 4 3 1 = supports timing mode 3 2 1 = supports timing mode 2 1 1 = supports timing mode 1 0 1 = supports timing mode 0, shall be 1	0FH(1.8V)/1FH(3.3V) 00H
131-132	O	Program cache timing mode support 6-1 5Reserved (0) 5 1 = supports timing mode 5 4 1 = supports timing mode 4 3 1 = supports timing mode 3 2 1 = supports timing mode 2 1 1 = supports timing mode 1 0 1 = supports timing mode 0,	0FH(1.8V)/1FH(3.3V) 00H
133-134	M	tPROG Maximum page program time (us)	58H 02H
135-136	M	tBERS Maximum block erase time (us)	10H 27H
137-138	M	tR Maximum page read time (us)	19H 00H
139-140	M	tCCS Minimum Change Column setup time (ns)	2CH 01H
141-163		Reserved	00H
		Vendor block	
164-165	M	Vendor specific Revision number	00H
166-253		Vendor specific	00H
254-255	M	Integrity CRC	
		Redundant parameter pages	
256-511	M	Value of bytes 0-255	
512-767	M	Value of bytes 0-255	
768+	O	Additional redundant parameter pages	

**Notes:**

1. "O" Stands for Optional, "M" for Mandatory
2. The Integrity CRC (Cycling Redundancy Check) field is used to verify that the contents of the parameters page were transferred correctly to the host. Please refer to ONFI 1.0 specifications for details.

The CRC shall be calculated using the following 16-bit generator polynomial:  $G(X) = X^{16} + X^{15} + X^2 + 1$

**Parameter page CRC value table**

Device Model	ORGANIZATION	VCC RANGE	CRC value B254/B255
"GD9FS4G8F4B"	512M x 8bit	1.7v ~ 1.95v	0CH/B6H
"GD9FS4G6F4B"	256M x 16bit	1.7v ~ 1.95v	F0H/DFH
"GD9FU4G8F4B"	512M x 8bit	2.7v ~ 3.6v	E1H/92H
"GD9FU4G6F4B"	256M x 16bit	2.7v ~ 3.6v	1DH/FBH

"GD9FS8G8E4B"	1G x 8bit	1.7v ~ 1.95v	BEH/25H
"GD9FS8G6E4B"	512M x 16bit	1.7v ~ 1.95v	42H/4CH
"GD9FU8G8E4B"	1G x 8bit	2.7v ~ 3.6v	53H/01H
"GD9FU8G6E4B"	512M x 16bit	2.7v ~ 3.6v	AFH/68H



### 8.6 Read Status (70H)

The device contains a Status Register which may be read to find out whether an operation is completed and whether the program or erase operation is completed successfully. After writing 70H command to the command register, a read cycle outputs the content of the Status Register to the I/O pins on the falling edge of CE# or RE#, whichever occurs last. This allows the system to poll the progress of each device in multiple memory connections even when R/B# pins are common-wired. RE# or CE# does not need to be toggled for updated status. The command register remains in Status Read mode until further commands are issued to it. Therefore, if the status register is read during a random read cycle, the read command (00h) should be given before starting read cycles.

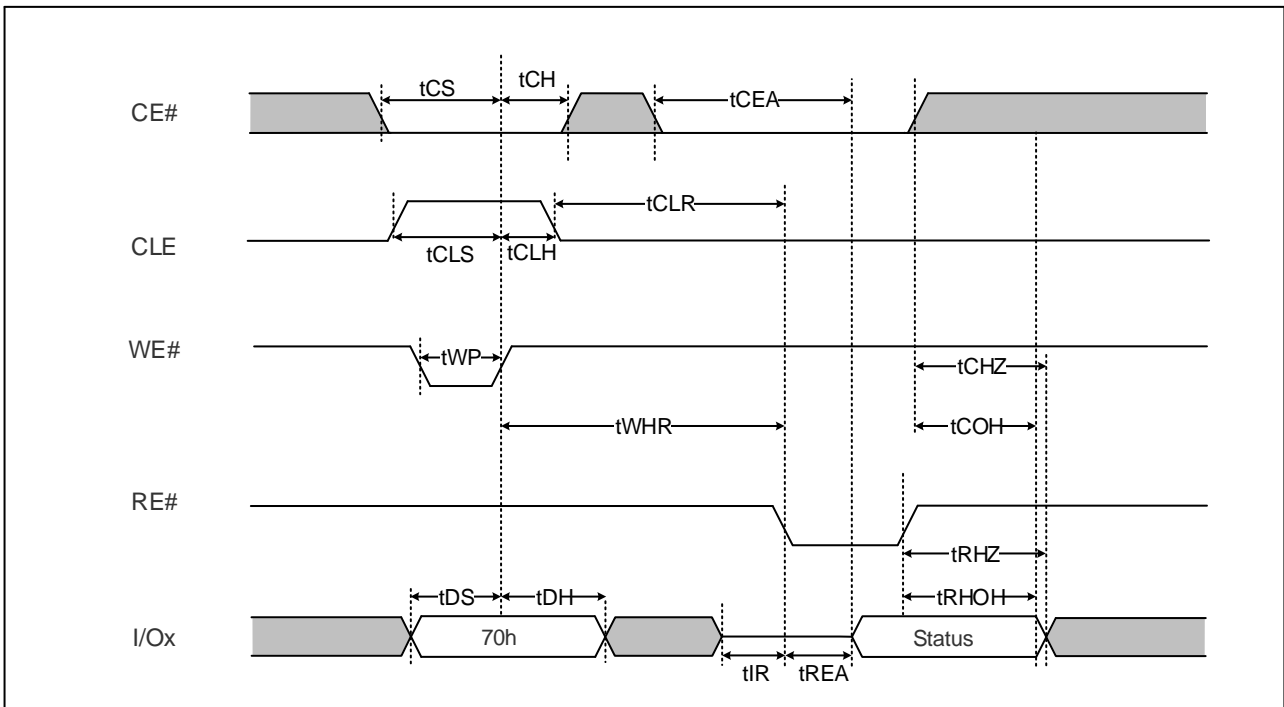

Figure 8-25: Read Status Figure



## Status Register Definitions

I/O No.	Page Program	Block Erase	Cache Program	Read	Cache Read	Definition
I/O0	Pass/Fail	Pass/Fail	Pass/Fail(N)	-	-	FAIL N Page Pass : 0 Fail : 1
I/O1	-	-	Pass/Fail(N-1)	-	-	FAILC N-1 Page Pass : 0 Fail : 1
I/O2	-	-	-	-	-	Don't Care
I/O3	-	-	-	-	-	Don't Care
I/O4	-	-	-	-	-	Don't Care
I/O5	Ready/Busy	Ready/Busy	Ready/Busy	Ready/Busy	Ready/Busy	ARDY Ready/Busy for Array Operation Busy : 0 Ready : 1
I/O6	Ready/Busy	Ready/Busy	Ready/Busy	Ready/Busy	Ready/Busy	RDY Ready/Busy Busy : 0 Ready : 1
I/O7	Write Protect	Write Protect	Write Protect	Write Protect	Write Protect	WP# Protected:0 Not Protected:1

## Notes:

1. I/O0: This bit is only valid for Program and Erase operations. During Cache Program operations, this bit is only valid when I/O5 is set to high.
2. I/O1: This bit is only valid for cache program operations. This bit is not valid until after the second 15h command or the 10h command has been transferred in a Cache program sequence.
3. I/O5: If set to high, then there is no array operation in progress. If cleared to low, then there is a command being processed (I/O6 is cleared to low) or an array operation in progress.
4. I/O6: When cache operations are in use, then this bit indicates whether another command can be accepted, and I/O5 indicates whether the operation is complete.
5. I/O7: the bit indicates if the block is protected, which include WP# protection and other protection.

## 8.7 Read Status Enhanced – ONFI (78H)

Read Status Enhanced is an additional feature used to retrieve the status value for a previous Operation in the following cases:

- On a specific plane in case of multi-plane operations in the same die.

Follow figure defines the Read Status Enhanced behavior and timings. Writing 78h to the command register, followed by three row address cycles containing the page, block.

The command register remains in Status Read mode until further commands are issued.

Read Status Enhanced command is prohibited during the reset (FFH) command and when OTP mode is enable.

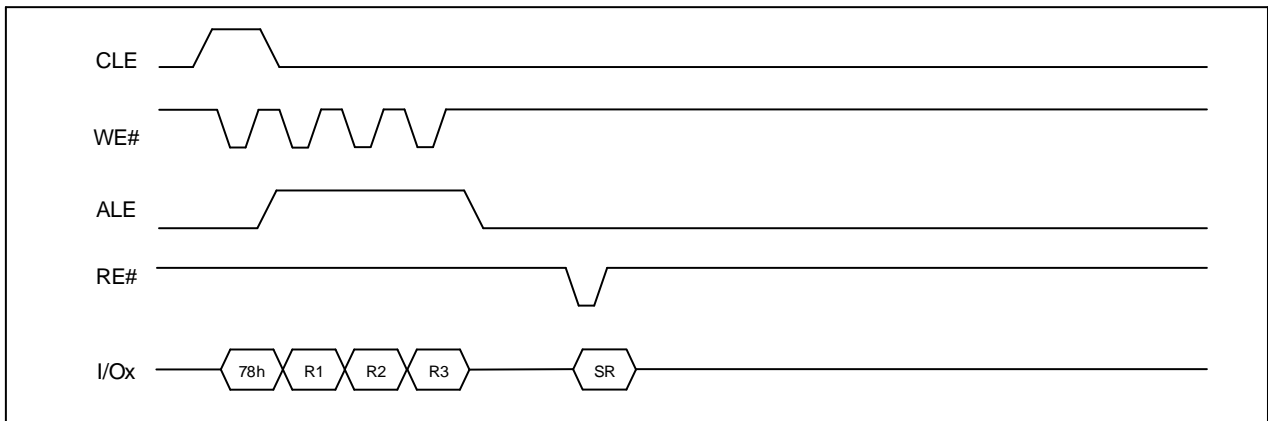

Figure 8-26: Read Status Enhanced-ONFI Figure

Note: SR, status register

R1/R2/R3: row address for status read.





### 8.8 Ready/Busy# (R/B#)

The device has a Ready/Busy output that provides method of indicating the completion of a page program, erase, copy-back and random read completion. The R/B# pin is normally high and goes to low when the device is busy (after a reset, read, program, and erase operation). It returns to high when the internal controller has finished the operation. The pin is an open-drain driver thereby allowing two or more R/B# outputs to be Or-tied. Because pull-up resistor value is related to tR (R/B#), an appropriate value can be obtained with the following reference below chart. Its value can be determined by the following guidance.

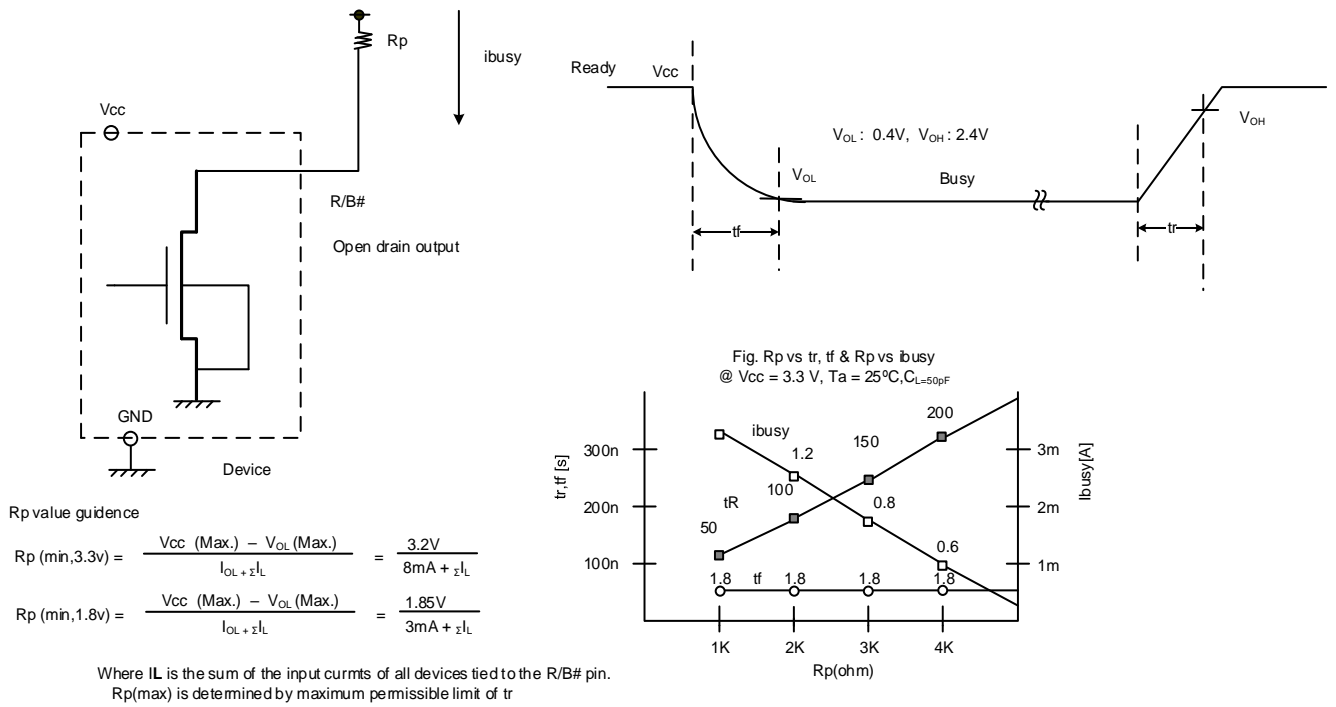

Figure 8-27: Ready/Busy Figure



### 8.9 Data Protection & Power on/off Sequence

The device is designed to offer protection from any involuntary program/erase during power-transitions. An internal voltage detector disables all functions whenever VCC is below Vth. WP# pin provides hardware protection and is recommended to be kept at VIL during power-up and power-down.

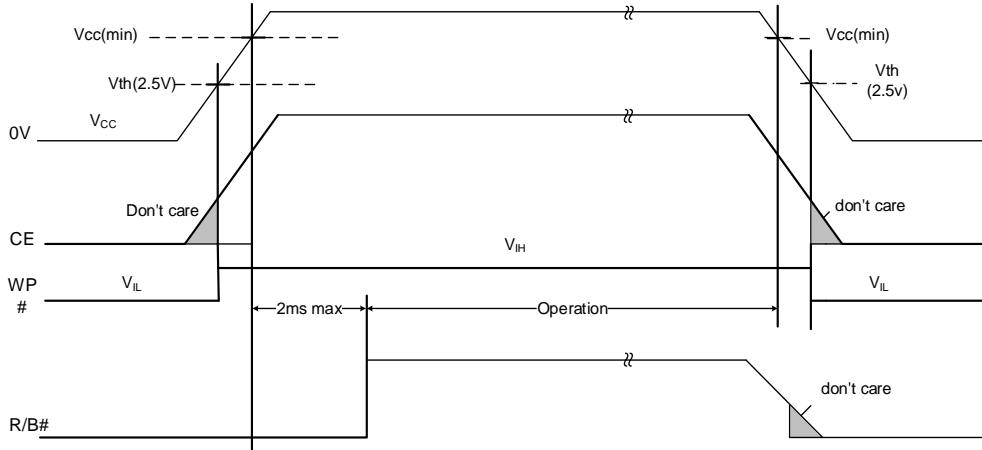

Figure 8-28\_a: Data protection and Power on/off (3.3V Device)

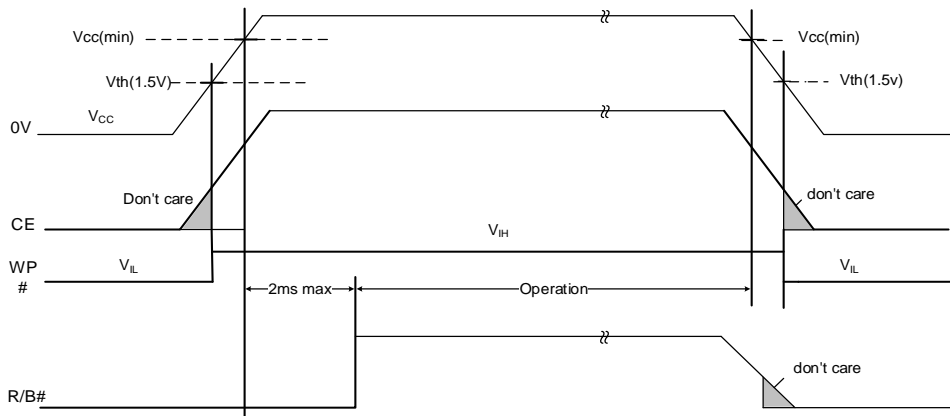

Figure 8-28\_b: Data protection and Power on/off (1.8V Device)



## 8.10 Multi-Plane Operation Limitation

Multi-plane commands require an address per operational plane. For a given multi-plane operation, these addresses are subject to the following requirements:

- The plane address bits must be different for each issued address.
- The page address bits must be identical for each issued address.
- Multi-plane copy back cannot cross plane boundaries.
- Multi-plane operation should in the same LUN.



### 8.11 Addressing for program operation

Within a block, the pages must be programmed consecutively from the LSB (least significant bit) page of the block to MSB (most significant bit) page of the block. Random page address programming is prohibited.

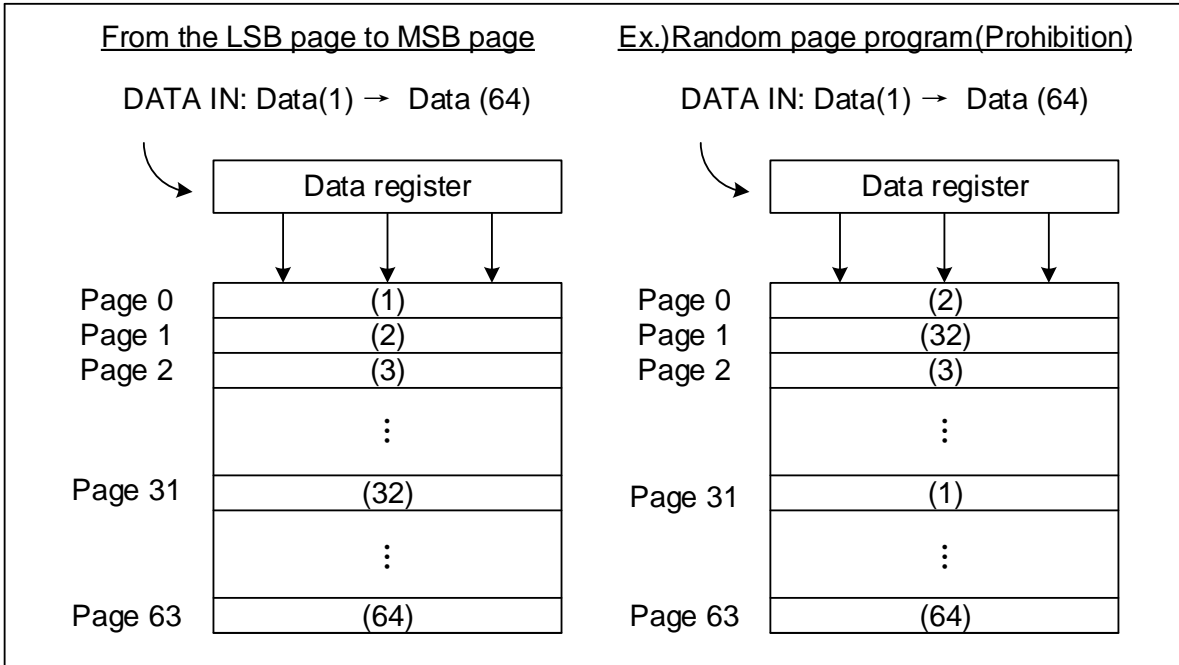



### 8.12 Several programming cycles on the same page (Partial Page Program)

Each segment can be programmed individually as follows:

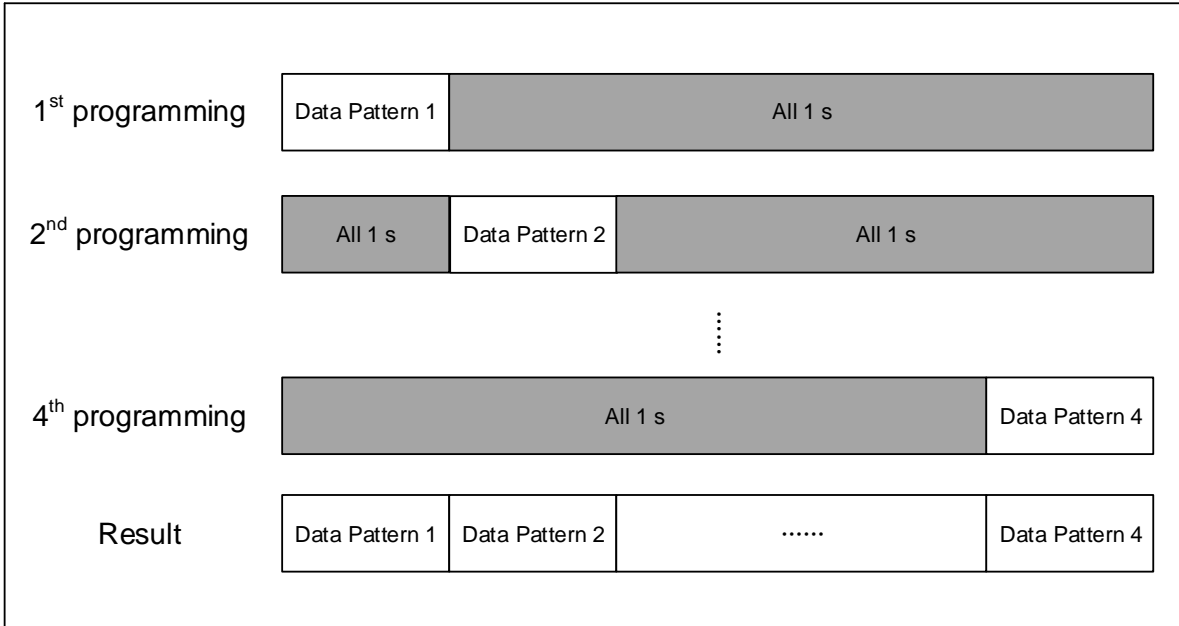



### 9. ABSOLUTE MAXIMUM RATINGS

Parameter	Symbol	Value	Unit
Voltage on any pin relative to VSS	VIN/OUT	-0.6 to VCC+0.4	V
	VCC(3.3V)	-0.6 to + 4.0	
	VCC(1.8V)	-0.6 to + 2.5	
Temperature Under Bias	TBIAS	-50 to +125	°C
Storage Temperature	TSTG	-65 to +150	°C

**Notes:**

1. Minimum DC voltage is -0.6V on input/output pins.
2. Permanent device damage may occur if ABSOLUTE MAXIMUM RATINGS are exceeded. Exposure to absolute maximum rating conditions for extended periods may affect reliability.

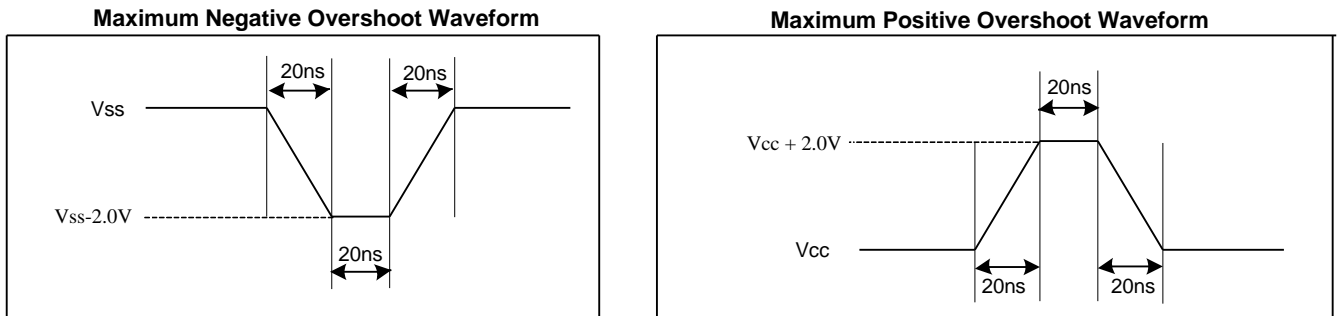

Figure 9-1. Input Test Waveform and Measurement Level



## 10. Valid Blocks

	Symbol	Min	Typ.	Max	Unit
Valid Block Number for 4Gb	NVB	2008		2048	Blocks
Valid Block Number for 8Gb	NVB	4016		4096	Blocks

**Notes:**

1. The 1<sup>st</sup> block is guaranteed to be a valid block with ECC at the time of shipment.
2. Invalid blocks are one that contains one or more bad bits. The device may contain invalid blocks upon shipment.



## 11. DC CHARACTERISTICS

Parameter		Symbol	Test Conditions	1.7v ~ 1.95v / 2.7v ~ 3.6v			Unit
				Min	Typ.	Max	
Power on reset current		ICC0	FFh command after power on			50	mA
Operating Current	Page Read with Serial Access	ICC1	tRC=Min, CE#=VIL, IOUT=0 Ma	-	15	30	mA
	Program	ICC2	-	-	15	30	
	Erase	ICC3	-	-	15	30	
Standby Current (CMOS)		ICC4	CE#=VCC-0.2, WP#=0V/VCC		10	50	uA
Input Leakage Current		ILI	VIN=0 to VCC(max)	-	-	±10	uA
Output Leakage Current		ILO	VOUT=0 to VCC(max)	-	-	±10	uA
Input High Voltage		VIH	-	0.8*VCC	-	VCC+0.3	V
Input Low Voltage		VIL	-	-0.3	-	0.2*VCC	
Output High Voltage Level		VOH	IOH=-400 uA	VCC-0.3	-	-	
Output Low Voltage Level		VOL	IOL=2.1 mA	-	-	0.4	
Output Low Current(R/B#)		IOL(R/B#)	VOL=0.4V	3/8	4/10	-	mA





## 12. AC CHARACTERISTICS

### 12.1 Test Condition

(TA=-40 to 85°C VCC=1.7V~1.95V /2.7V~3.6V)

Parameter	GD9Fx4GxF4B/GD9Fx8GxE4B
Input Pulse Levels	0V to VCC
Input Rise and Fall Times	5ns
Input and Output Timing Levels	VCC/2
Output Load	1 TTL GATE and CL=30pF for 1.8v and CL=50pF for 3.3v

### 12.2 Capacitance (TA=25°C, F=1.0 Mhz)

Parameter for 4Gb	Symbol	Test condition	Min	Max	Unit
Input/Output Capacitance	CI/O	VIL=0V	-	10	pF
Input Capacitance	CIN	VIN=0V	-	10	pF

Notes:

1. Capacitance is periodically sampled and not 100% tested.
2. Capacitance (CI/O and CIN) for 8Gb is 20pF.



## 12.3 AC Timing Characteristics

Parameter	Symbol	3.3V		1.8V		
		Min	Max	Min	Max	
CE# setup time	tCS	15	-	20	-	ns
CE# hold time	tCH	5	-	5	-	ns
CLE setup time	tCLS	10	-	10	-	ns
CLE Hold time	tCLH	5	-	5	-	ns
ALE setup time	tALS	10	-	10	-	ns
ALE hold time	tALH	5	-	5	-	ns
Data setup time	tDS	10	-	10	-	ns
Data hold time	tDH	5	-	5	-	ns
Write cycle time	tWC	25	-	30	-	ns
WE# pulse width	tWP	12	-	15	-	ns
WE# high hold time	tWH	10	-	12	-	ns
Address to data loading time	tADL	150	-	150	-	ns
WE# high to busy	tWB	-	100	-	100	ns
Ready to RE# low	tRR	20	-	20	-	ns
CLE to RE# delay	tCLR	10	-	10	-	ns
ALE to RE# delay	tAR	10	-	10	-	ns
Read cycle time	tRC	25	-	30	-	ns
RE# pulse width	tRP	12	-	15	-	ns
RE# high hold time	tREH	10	-	10	-	ns
RE# access time	tREA	-	20	-	25	ns
CE# access time	tCEA	-	25	-	25	ns
RE# high to output high Z	tRHZ	-	100	-	100	ns
CE# high to output high Z	tCHZ	-	50	-	50	ns
CE# high to output hold	tCOH	15	-	15	-	ns
RE# high to output hold	tRHOH	15	-	15	-	ns
RE# low to output hold	tRLOH	3	-	3	-	ns
Output Hi-Z to RE# Low	tIR	0	-	0	-	ns
RE# high to WE# low	tRHW	100	-	100	-	ns
WE# high to RE# low	tWHR	60	-	60	-	ns
Write protect time	tWW	100	-	100	-	ns



## 12.4 Performance Characteristics

Parameter	Symbol	Min	Typ.	Max	Unit
Data transfer from cell to register	tR			25	us
Program Time	tPROG	-	300	600	μs
Read Cache busy time	tCBSYR		5	tR	μs
Cache Program short busy time	tCBSYW		5	tPROG	μs
Dummy busy time	tDBSY		0.5	1	us
Number of Partial Program Cycles in the Same Page	NOP			4	cycles
Block Erase Time	tBERS	-	3	10	ms
Device resetting time	Read			10	us
	Program			20	us
	Erase			500	us

**Note:**

1. Typical value is measured at Ta=25°C.

### 13. PACKAGE INFORMATION

#### 13.1 TSOPI-48

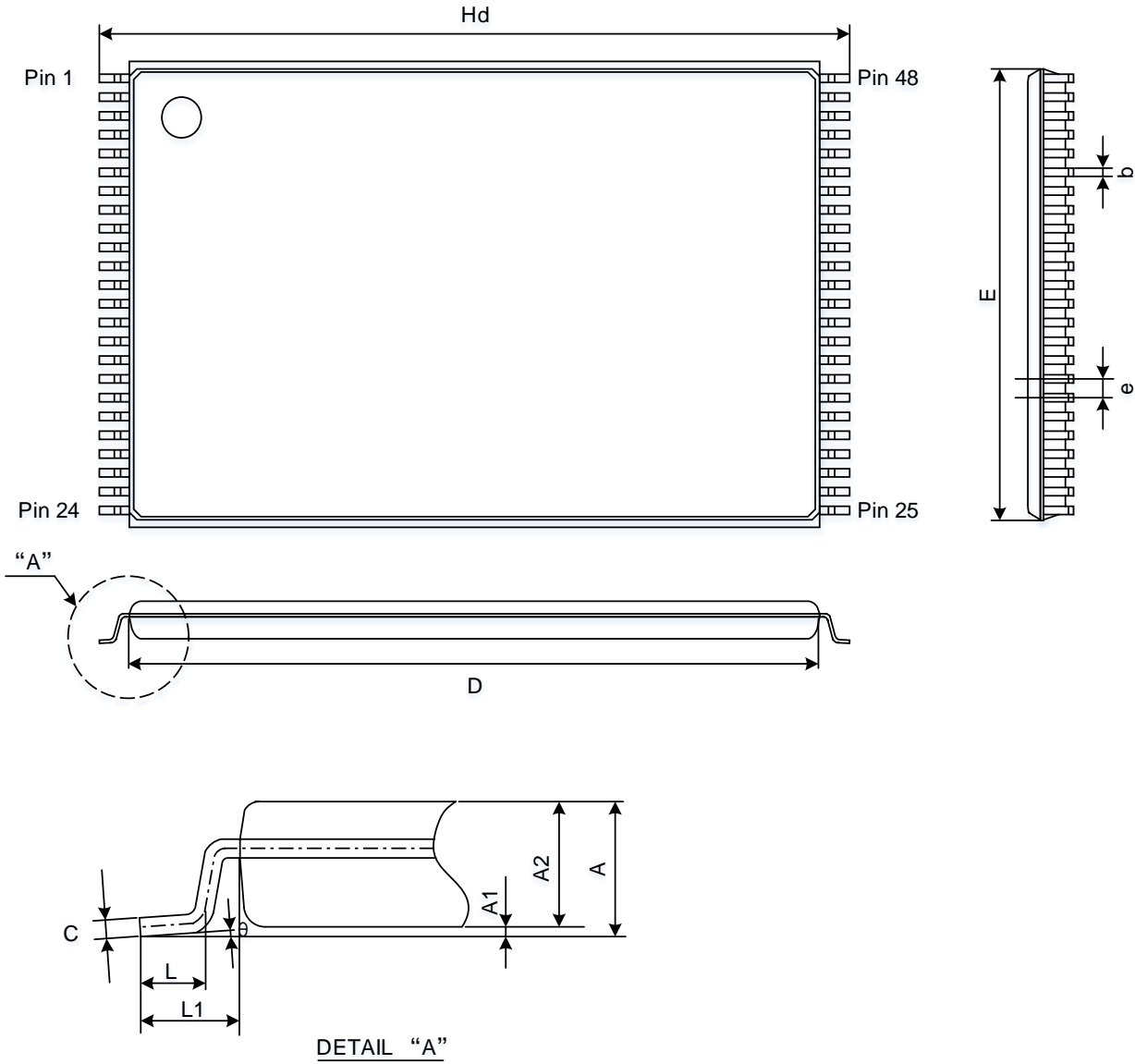

Figure 13-1: TSOPI-48 Figure

#### Dimensions

Symbol		A	A1	A2	c	b	D	Hd	E	e	L	L1	θ
Unit													
mm	Min	-	0.05	0.90	0.125	0.20	18.30	19.80	11.90	0.50	0.400	0.70	0
	Nom	-	0.10	1.00			18.40	20.00	12.00		0.500	0.80	-
	Max	1.20	0.15	1.10			18.50	20.20	12.10		0.600	0.90	7



Note:

1. Tolerance of the dimension should be  $\pm 0.1$  unless otherwise specified.
2. Corner radius should be less than  $\pm 0.1R$  unless otherwise specified (excluding outer lead).
3. Tolerance of the angles should be  $\pm 0.5$  degree unless otherwise specified.
4. The mold surface should have a finish  $8\pm 2S$  without luster.  
Trace of knockout pin and the shaded portion of detail "A" should be polish surface.
5. Discrepancies between upper and lower molding cavity should be less than 0.05 of the package.
6. Mold flash should be less than 0.2mm.



13.2 FBGA-63

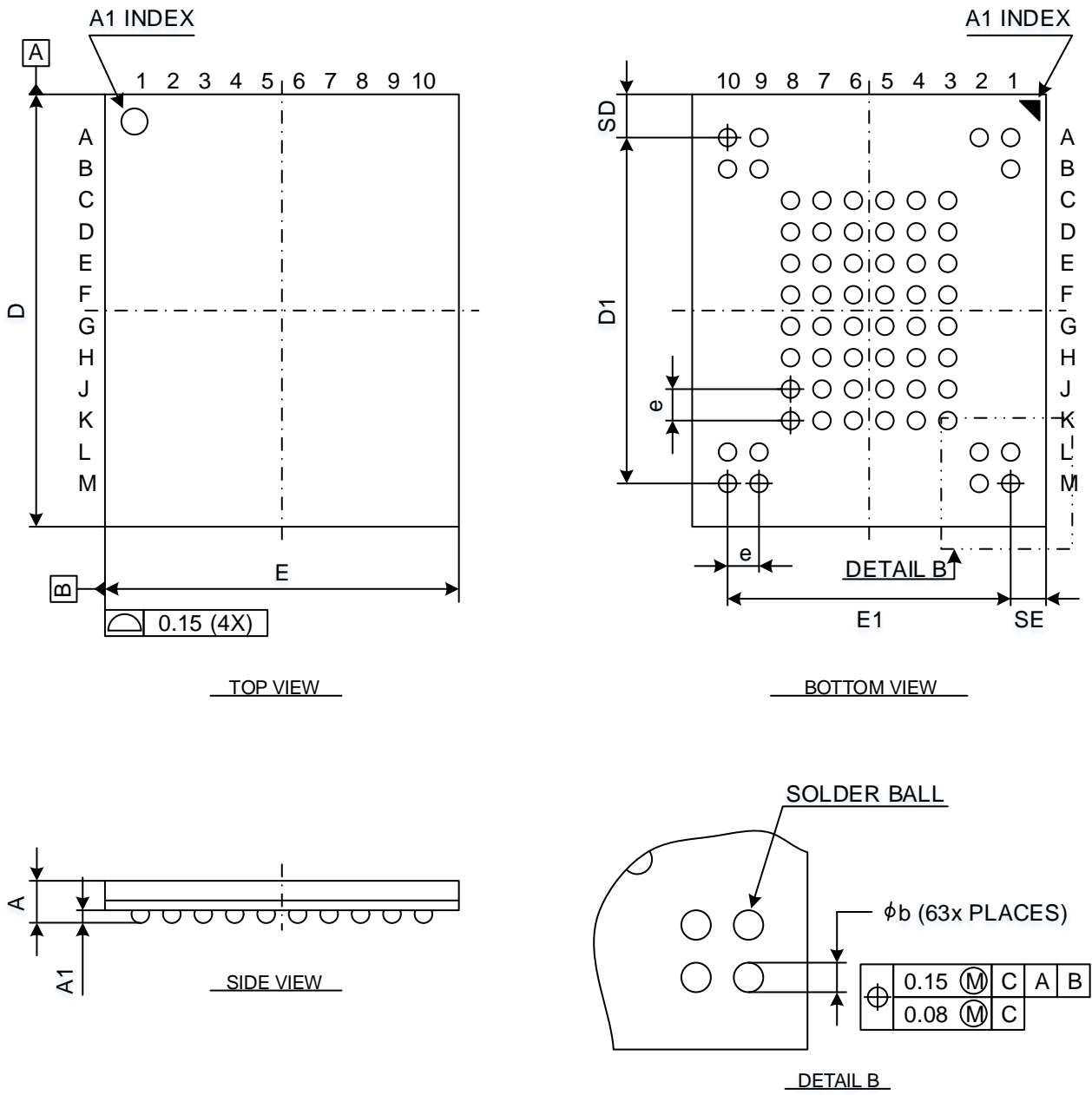

Figure 13-2: FBGA-63 figures

**Dimensions**

Symbol		A	A1	b	E	E1	D	D1	e	SD	SE
Unit											
mm	Min	-	0.25	0.40	8.90	7.20 BSC	10.90	8.80 BSC	0.80 BSC	1.10 TYP	0.90 TYP
	Nom	-	0.30	0.45	9.00		11.00				
	Max	1.00	0.40	0.50	9.10		11.10				

Note:

1. Controlling dimension: millimeter.
2. Reference document: JEDEC MO-207
3. The diameter of pre-reflow solder ball is  $\varnothing 0.42\text{mm}$  (0.40mm SMO).



### 13.3 FBGA-67

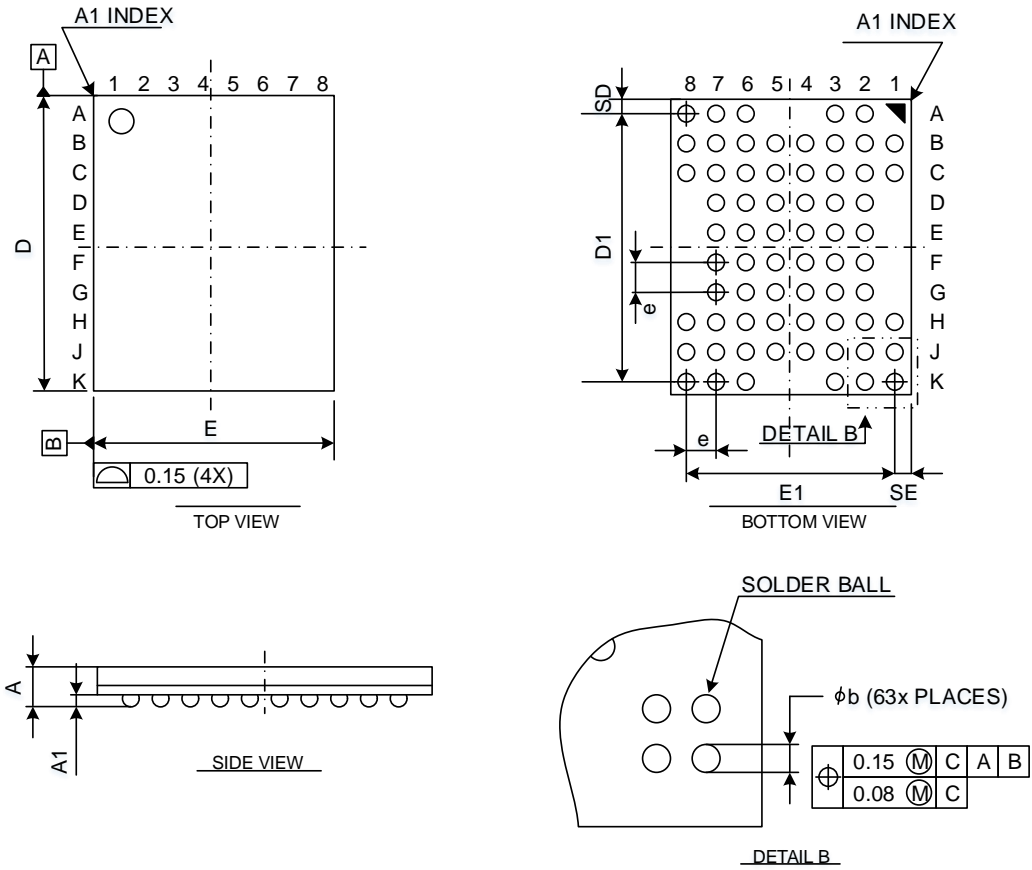

Figure 13-3: FBGA-67 figures

#### Dimensions

Symbol		A	A1	b	E	E1	D	D1	e	SD	SE
Unit											
mm	Min	-	0.22	0.40	-	5.60	-	7.20	0.80	0.40	0.45
	Nom	-	0.26	0.45	6.50	BSC	8.00	BSC	BSC	TYP	TYP
	Max	1.00	0.30	0.50	-		-				

Note:

- Controlling dimension: millimeter.





## 14. Part Numbering Information

GD 9F U 4G 8 F 4 B M G I  
 1      2      3      4      5      6      7      8      9      10      11

### 1. GD

### 2. Memory Type

9F: Parallel NAND without Internal ECC

9A: Parallel NAND with Internal ECC

### 3. Power Supply

	VCCQ	VCC
U	2.7v ~ 3.6v	2.7v ~ 3.6v
S	1.7v ~ 1.95v	1.7v ~ 1.95v

### 4. Density:

1G: 1Gb

2G: 2Gb

4G: 4Gb

8G: 8Gb

AG: 16Gb

### 5. Organization

8: x8

6: x16

### 6. NAND Type:

F: SLC, 1Die, 1nCE, 1Rnb

E: SLC; 2Die, 1nCE, 1Rnb

D: SLC; 4Die, 1nCE, 1Rnb

### 7. Function Mode:

4: Spare size is 256bytes

### 8. Process Generation:

A: A GEN

B: B GEN

### 9. Package

M: TSOPI-48

L: FBGA-63

W: Wafer

### 10. Package Material & Packing

G: Lead &amp; Halogen Free

W: Wafer

### 11. Temperature Grade

I: Industrial (-40°C ~ 85°C)

F: Industrial+ (-40°C ~ 85°C)

Note: (1) Industrial+: F grade has implemented additional test flows to ensure higher product quality than I grade.



## 15. Revision History

Version No.	History Description	Date	Page
1.0	Initial Release	2020-09-17	

## Important Notice

This document is the property of GigaDevice Semiconductor (Beijing) Inc. and its subsidiaries (the "Company"). This document, including any product of the Company described in this document (the "Product"), is owned by the Company under the intellectual property laws and treaties of the People's Republic of China and other jurisdictions worldwide. The Company reserves all rights under such laws and treaties and does not grant any license under its patents, copyrights, trademarks, or other intellectual property rights. The names and brands of third party referred thereto (if any) are the property of their respective owner and referred to for identification purposes only.

The Company makes no warranty of any kind, express or implied, with regard to this document or any Product, including, but not limited to, the implied warranties of merchantability and fitness for a particular purpose. The Company does not assume any liability arising out of the application or use of any Product described in this document. Any information provided in this document is provided only for reference purposes. It is the responsibility of the user of this document to properly design, program, and test the functionality and safety of any application made of this information and any resulting product. Except for customized products which has been expressly identified in the applicable agreement, the Products are designed, developed, and/or manufactured for ordinary business, industrial, personal, and/or household applications only. The Products are not designed, intended, or authorized for use as components in systems designed or intended for the operation of weapons, weapons systems, nuclear installations, atomic energy control instruments, combustion control instruments, airplane or spaceship instruments, traffic signal instruments, life-support devices or systems, other medical devices or systems (including resuscitation equipment and surgical implants), pollution control or hazardous substances management, or other uses where the failure of the device or Product could cause personal injury, death, property or environmental damage ("Unintended Uses"). Customers shall take any and all actions to ensure using and selling the Products in accordance with the applicable laws and regulations. The Company is not liable, in whole or in part, and customers shall and hereby do release the Company as well as its suppliers and/or distributors from any claim, damage, or other liability arising from or related to all Unintended Uses of the Products. Customers shall indemnify and hold the Company as well as its suppliers and/or distributors harmless from and against all claims, costs, damages, and other liabilities, including claims for personal injury or death, arising from or related to any Unintended Uses of the Products. Customers shall discard the device according to the local environmental law.

**Information in this document is provided solely in connection with the Products. The Company reserves the right to make changes, corrections, modifications or improvements to this document and the Products and services described herein at any time, without notice.**