

- Typical Applications
- CDMA PCS/Cellular Handsets
  - TDMA PCS/Cellular Handsets
  - W-CDMA Handsets

Product Description

The RF2377 is a linear variable gain amplifier suitable for use in TDMA and CDMA systems in the cellular or PCS band and for W-CDMA systems. The features of this device include linear gain control, high gain, and high linearity. The IC is manufactured on an advanced Gallium Arsenide Heterojunction Bipolar Transistor (GaAs HBT) process and is featured in an industry-standard miniature 6-lead plastic SOT package.

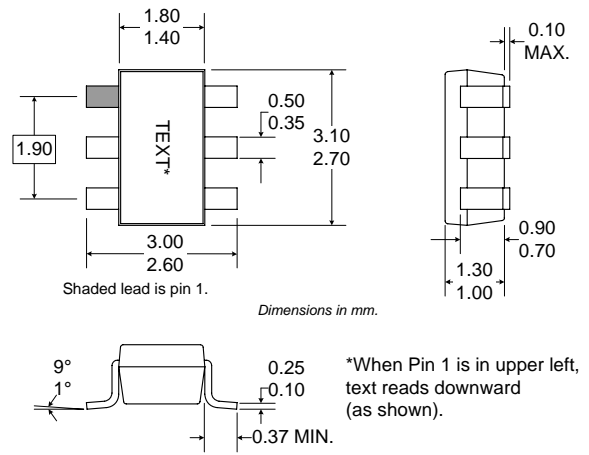

Optimum Technology Matching® Applied

- |                                     |  |                                       |
|-------------------------------------|--|---------------------------------------|
| <input type="checkbox"/> Si BJT     | <input checked="" type="checkbox"/> GaAs HBT | <input type="checkbox"/> GaAs MESFET  |
| <input type="checkbox"/> Si Bi-CMOS | <input type="checkbox"/> SiGe HBT            | <input type="checkbox"/> Si CMOS      |
| <input type="checkbox"/> InGaP/HBT  | <input type="checkbox"/> GaN HEMT            | <input type="checkbox"/> SiGe Bi-CMOS |

Package Style: SOT23-6

- Features
- 50dB Linear Gain Control Range
  - 24dB Maximum Gain
  - Single 2.7V to 3.3V Supply
  - 45mA Supply Current
  - High Linearity

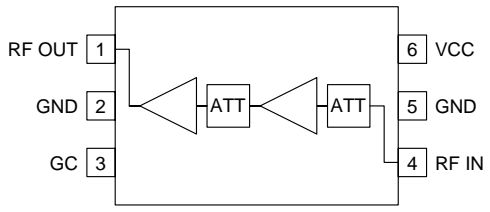

Functional Block Diagram

Ordering Information

RF2377 PCS/Cellular TDMA/CDMA/W-CDMA Linear Variable Gain Amplifier

RF2377-410 PCB Fully Assembled Evaluation Board, PCS

RF2377-411 PCB Fully Assembled Evaluation Board, W-CDMA

RF Micro Devices, Inc. Tel (336) 664 1233  
7628 Thorndike Road Fax (336) 664 0454  
Greensboro, NC 27409, USA <http://www.rfmd.com>

# RF2377

## Absolute Maximum Ratings

Parameter	Rating	Unit
Supply Voltage	0 to +5.0	V <sub>DC</sub>
DC Current	100	mA
Operating Ambient Temperature	-20 to +85	°C
Storage Temperature	-40 to +150	°C



**Caution!** ESD sensitive device.

RF Micro Devices believes the furnished information is correct and accurate at the time of this printing. However, RF Micro Devices reserves the right to make changes to its products without notice. RF Micro Devices does not assume responsibility for the use of the described product(s).

Parameter	Specification			Unit	Condition
	Min.	Typ.	Max.		
<b>Overall</b>					V <sub>CC</sub> =2.8V, V <sub>GC</sub> =2.0V, T=25°C
Usable Frequency Range		800 to 2200		MHz	
Linear Gain Control Range	50			dB	
Gain Control Slope		70		dB/V	
<b>TDMA</b>					V <sub>CC</sub> =2.8V, V <sub>GC</sub> =2.0V, T=25°C
Operating Frequency		1880		MHz	
Maximum Small Signal Gain	22	24	27	dB	Over entire gain control range
Input VSWR		1.5:1	2.5:1		
Output IP3	+23	+26		dBm	
Noise Figure		7		dB	Maximum gain
Maximum Average Output Power		+8		dBm	TDMA modulation
Adjacent Channel Power Rejection		-33	-32	dBc	TDMA modulation; P <sub>OUT</sub> =+8dBm
Alternate Channel Power Rejection		-61	-57	dBc	TDMA modulation; P <sub>OUT</sub> =+8dBm
<b>CDMA</b>					V <sub>CC</sub> =2.8V, V <sub>GC</sub> =2.0V, T=25°C
Operating Frequency		1880		MHz	
Maximum Small Signal Gain	22	24	27	dB	Over entire gain control range
Input VSWR		1.5:1	2.5:1		
Output IP3	+23	+26		dBm	
Noise Figure		7		dB	Maximum gain
Maximum Average Output Power		+11		dBm	CDMA modulation; V <sub>CC</sub> =3.0V, maximum gain setting, ACPR <sub>≤</sub> -52dBc.
Adjacent Channel Power Rejection		-53		dBc	CDMA modulation; V <sub>CC</sub> =3.0V. For P <sub>IN</sub> >-16dBm, adjustment of P <sub>IN</sub> is required to maintain ACPR performance over gain control range. For P <sub>IN</sub> ≤-16dBm, ACPR performance is maintained over entire gain control range.
<b>W-CDMA</b>					V <sub>CC</sub> =2.8V, T=25°C
Operating Frequency		1920 to 1980		MHz	
Small Signal Gain	20	22	24	dB	V <sub>GC</sub> =2.0V
	-33	-32	-31	dB	V <sub>GC</sub> =0.3V
Input VSWR		1.5:1	2.5:1		Over entire gain control range
Output IP3	+22	+24		dBm	
Noise Figure	4	5	6	dB	Maximum gain
	32	32.5	34	dB	Minimum gain
Maximum Linear Output Power	+8	+9		dBm	W-CDMA ACPR<-46dBc, V <sub>GC</sub> =2.0V
Adjacent Channel Power Rejection		-48	-46	dBc	W-CDMA modulation; V <sub>GC</sub> =2.0V, P <sub>IN</sub> <-12dBm
			-43	dBc	W-CDMA modulation; Over entire gain control range, P <sub>IN</sub> <-17dBm
			-43	dBc	W-CDMA modulation; V <sub>GC</sub> =1.0V, P <sub>IN</sub> <-14dBm

Parameter	Specification			Unit	Condition
	Min.	Typ.	Max.		
<b>Power Supply</b>					T = 25°C
Supply Voltage		2.8		V	Specifications
Gain Control Voltage		2.7 to 3.3		V	Operating range
Supply Current	32	0 to 2.0	65	mA	$V_{CC}=2.8V, V_{GC}=2.0V$
		45		mA	$V_{CC}=3.0V, V_{GC}=2.0V$
		56		mA	$V_{CC}=2.8V, V_{GC}=0.4V$
$V_{GC}$ Current			20	mA	
			1.5	mA	

# RF2377

Pin	Function	Description	Interface Schematic
1	RF OUT	RF output pin. This pin is DC coupled and requires $V_{CC}$ through a bias inductor sized accordingly to provide a high pass transformation with a series capacitor.	
2	GND	Ground connection. Keep traces physically short and connect immediately to ground plane for best performance.	
3	GC	Analog gain control pin. This pin controls the gain of the IC. Minimum gain occurs at $V_{GC} < 0.4V$ and maximum gain is achieved with $V_{GC} = 2.0V$ . 50dB of linear gain control with little variation of input $P_{1dB}$ is available.	
4	RF IN	RF input pin. This pin is DC coupled.	
5	GND	Ground connection. Keep traces physically short and connect immediately to ground plane for best performance.	
6	VCC	Power supply. This pin should be connected to a regulated supply and requires a bypass capacitor. Voltage is supplied through this pin to the first stage collector; this voltage also controls the bias. Gain may be tuned by adjusting the value of the feed inductor.	

## Application Schematic

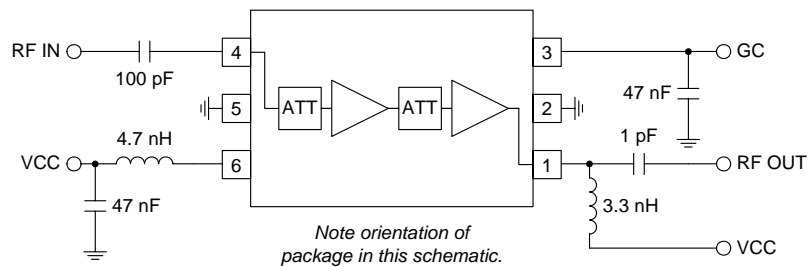

## W-CDMA Application Schematic

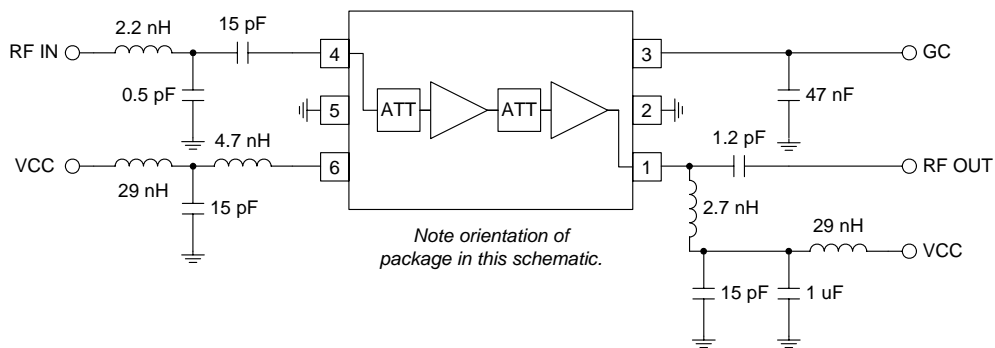

## Evaluation Board Schematic (W-CDMA)

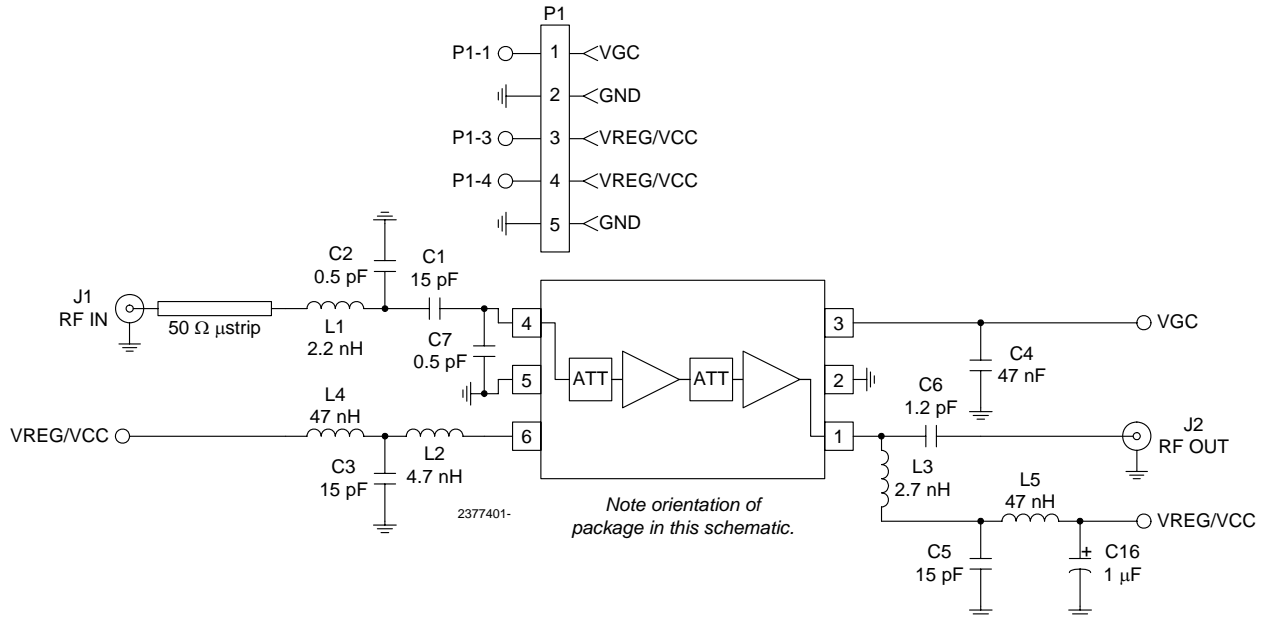

## Evaluation Board Schematic (PCS)

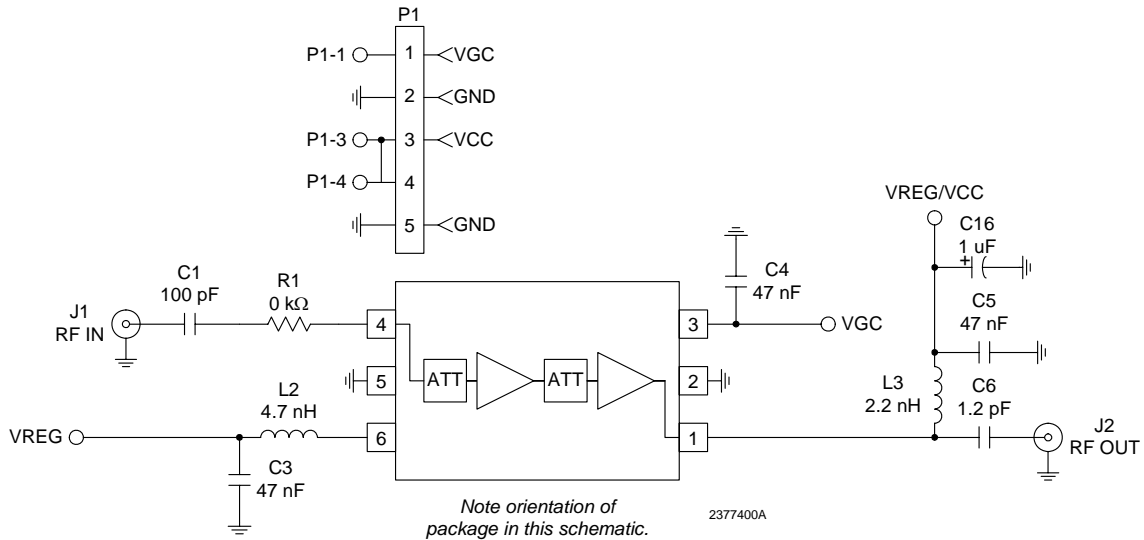

# RF2377

## Evaluation Board Layout (PCS) Board Size 2.0" x 2.0" Board Thickness 0.028", Board Material FR-4

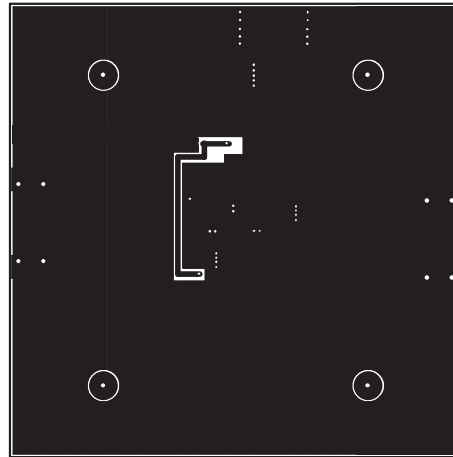
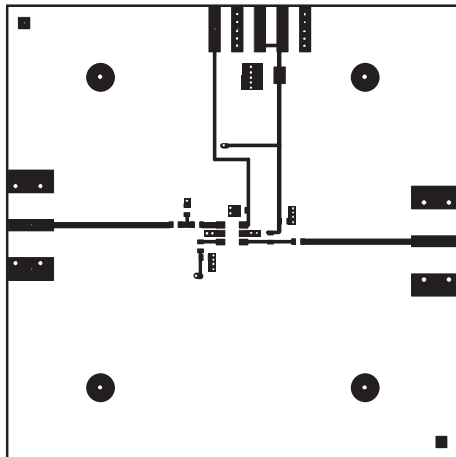
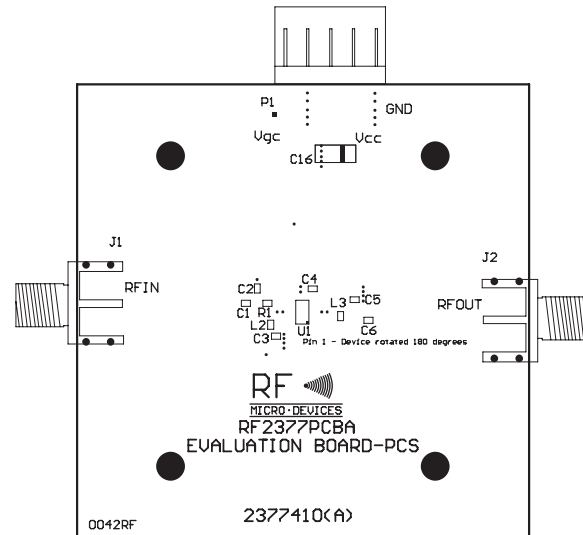

Evaluation Board Layout (W-CDMA)  
Board Size 2.0" x 2.0"  
Board Thickness 0.028", Board Material FR-4

