

Jul.1.2022 Copyright 2022 HIROSE ELECTRIC CO., LTD. All Rights Reserved.
In case of consideration for using Automotive equipment / device which demand high reliability, kindly contact our sales window correspondents.

- NOTES
- 1 WHEN MATING THE CONNECTOR, PLEASE HOLD MILLING AREA OF 6.4 ± 0.2 [mm] WITH A SPANNER NOT TO PLACE STRESS ON PCB BY THE TORQUE.
 - 2 0-80UNF-2B SCREW TIGHTENING TORQUE IS 0.09 N·m. PLEASE TIGHTEN THE SCREWS EVENLY WHEN MOUNTING THE CONNECTORS TO ENSURE STABLE ELECTRICAL CONTACT.
 - 3 PLEASE USE A PCB MOUNTING SCREW OF THE LENGTH OF L [mm/in]. THE LENGTH OF L [mm/in] IS PCB THICKNESS t1 + SPRING WASHER THICKNESS t2 + 1.8mm/0.071in. PLEASE USE A SCREW WITH SPRING WASHER.
 - 4 THE INDICATED DIMENSION IS THE CASE OF WHICH DIELECTRIC CONSTANT OF SUBSTRATE IS 3.6 AND THICKNESS IS t=0.2mm/0.008in. LAND PATTERN LAYOUT DEPENDS ALSO ON ELECTRIC CONSTANT, THICKNESS AND LAYER CONSTRUCTION OF PCB. FOR BETTER RF PERFORMANCE, SIMULATION OF PCB WITH CONNECTOR IS RECOMMENDED.
 - 5 RECOMMENDED PCB THICKNESS t1 IS GREATER THAN 1.0mm/0.04in.
 - 6 SIDE PLATING OF THE BOARD IS RECOMMENDED.
 - 7 THIS CONNECTOR SHOULD BE USE FOR TEST PORT ONLY.

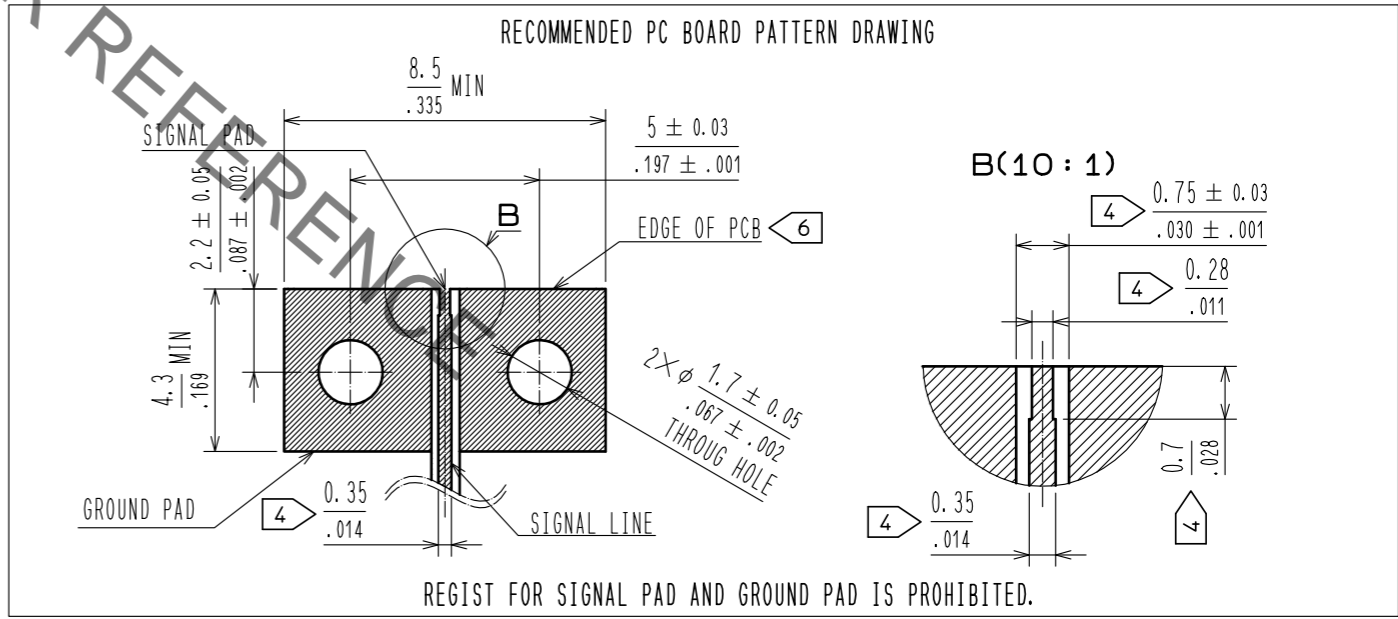
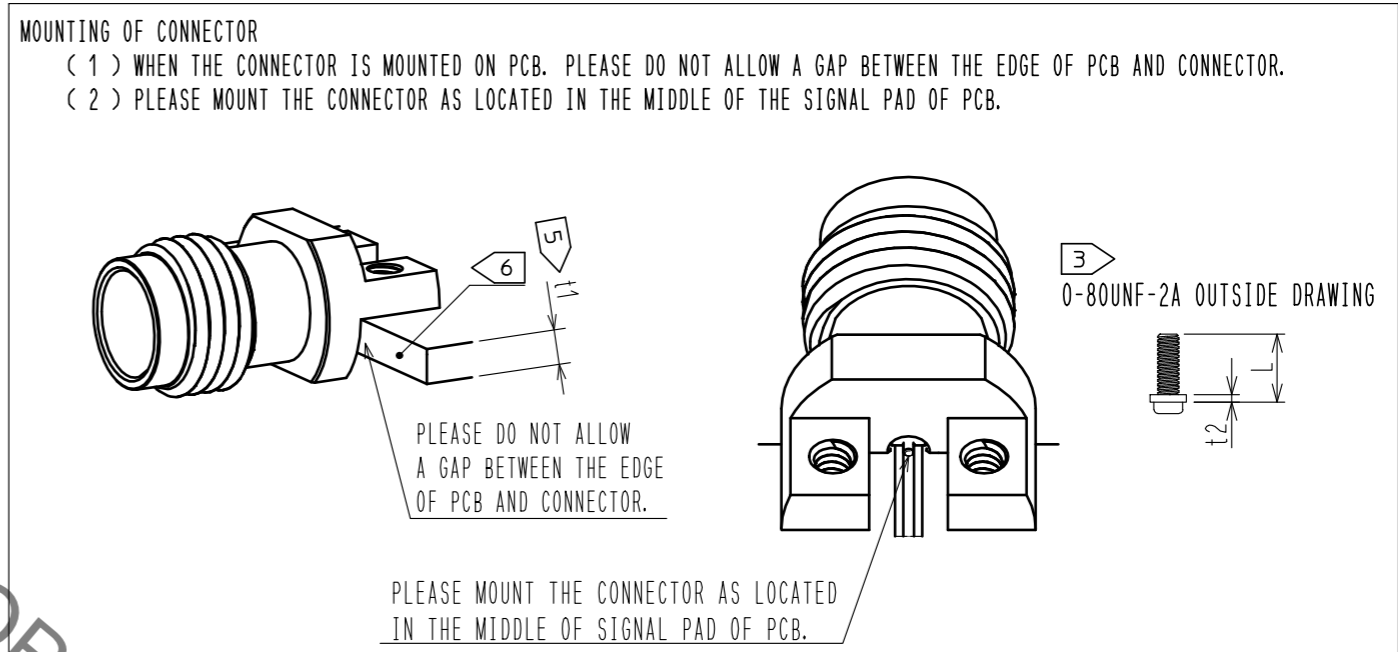
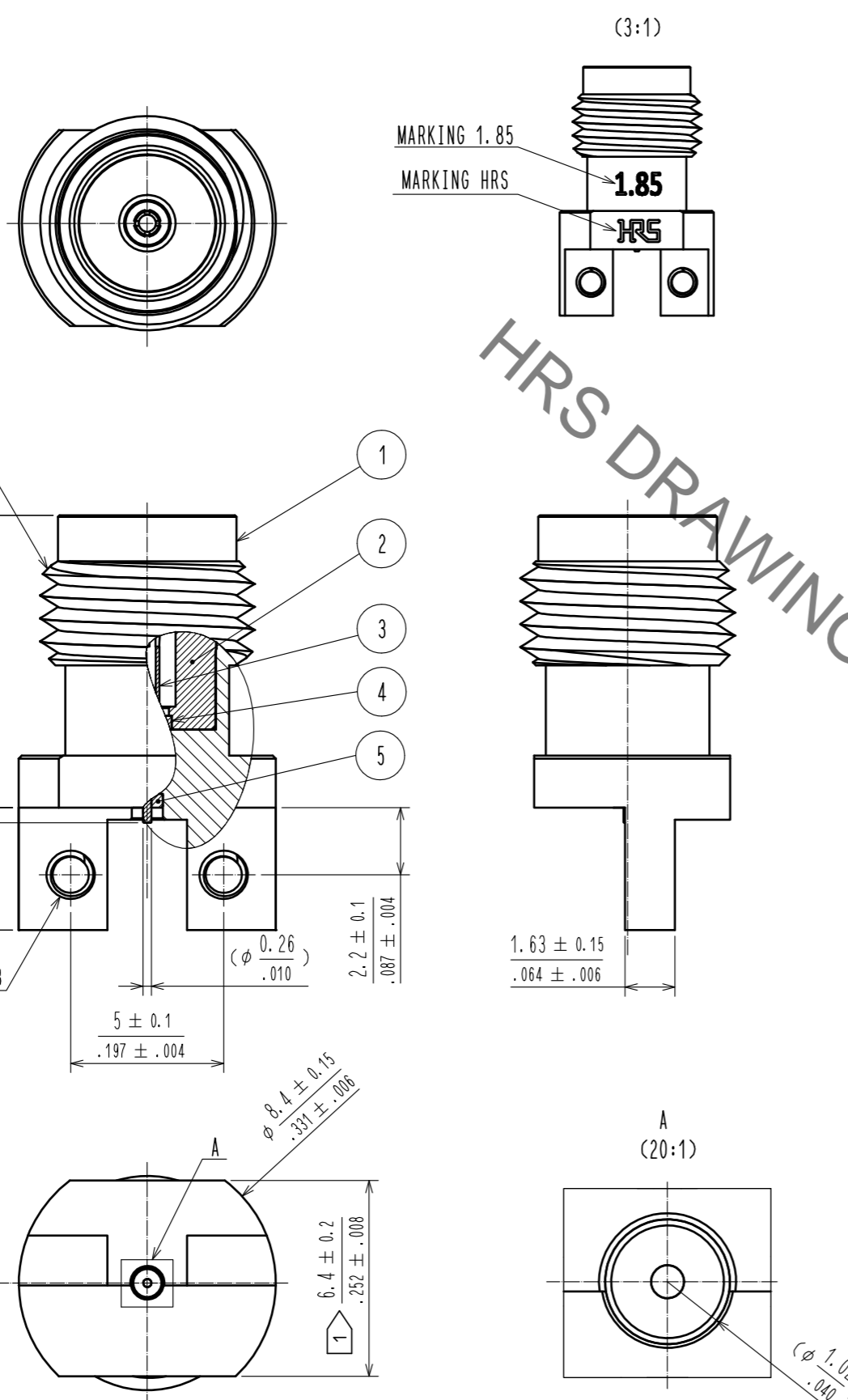

2	STAINLESS STEEL	PASSIVATE	5	POLYETHER IMIDE	
1	BRASS	GOLD PLATING	4	POLYETHER IMIDE	
			3	BERYLLIUM COPPER	GOLD PLATING
NO.	MATERIAL	FINISH . REMARKS	NO.	MATERIAL	FINISH . REMARKS
UNITS [mm/in]			SCALE 5:1	COUNT 1	DESCRIPTION OF REVISIONS DIS-D-00004426
APPROVED : TS. NOBE 20190823			DESIGNED : AH. MARUYAMA		
CHECKED : NK. NINOMIYA 20190822			CHECKED : NK. NINOMIYA		
DESIGNED : AH. MARUYAMA 20190821			DRAWING NO. EDC-384075-00-00		
DRAWN : AH. MARUYAMA 20190821			PART NO. HV-LR-SR2		
			CODE NO. CL338-0018-0-00		