

## 1.2A 3-Terminal Positive Voltage Regulator ME7805

### General Description

ME7805 is three-terminal positive regulators. One of these regulators can deliver up to 1.2A of output current. The internal limiting and thermal-shutdown features of the regulator make them essentially immune to overload. When used as a replacement for a zener diode-resistor Combination, an effective improvement in output impedance can be obtained, together with lower quiescent current.

### Features

- Output Current of 1.2A
- Output Voltages of  $5V \pm 5\%$  over the temperature range
- Thermal Overload Protection
- Short Circuit Protection
- Output transistor safe area protection
- No external components
- Package: TO-220

### Pin Configuration

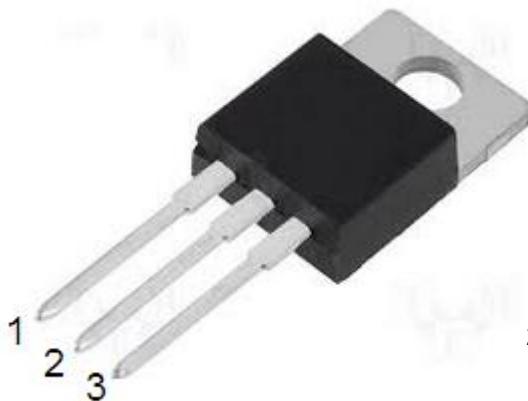

1. Input
2. GND
3. Output

### Absolute Maximum Ratings (Ta=25°C)

Parameter	Rating	Unit
Input supply voltage : $V_{IN}$	35	V
MAX. Output current: $I_{out}$	1200	mA
Operating Ambient Temperature Range: $T_{Opr}$	-40~+125	°C
Maximum junction temperature: $T_j$	-40~+150	°C
Storage temperature: $T_{str}$	-55~+150	°C
Soldering temperature and time	+260 (Recommended 10S)	°C

Caution: The absolute maximum ratings are rated values exceeding which the product could suffer physical damage.

These values must therefore not be exceeded under any conditions.

## Block Diagram

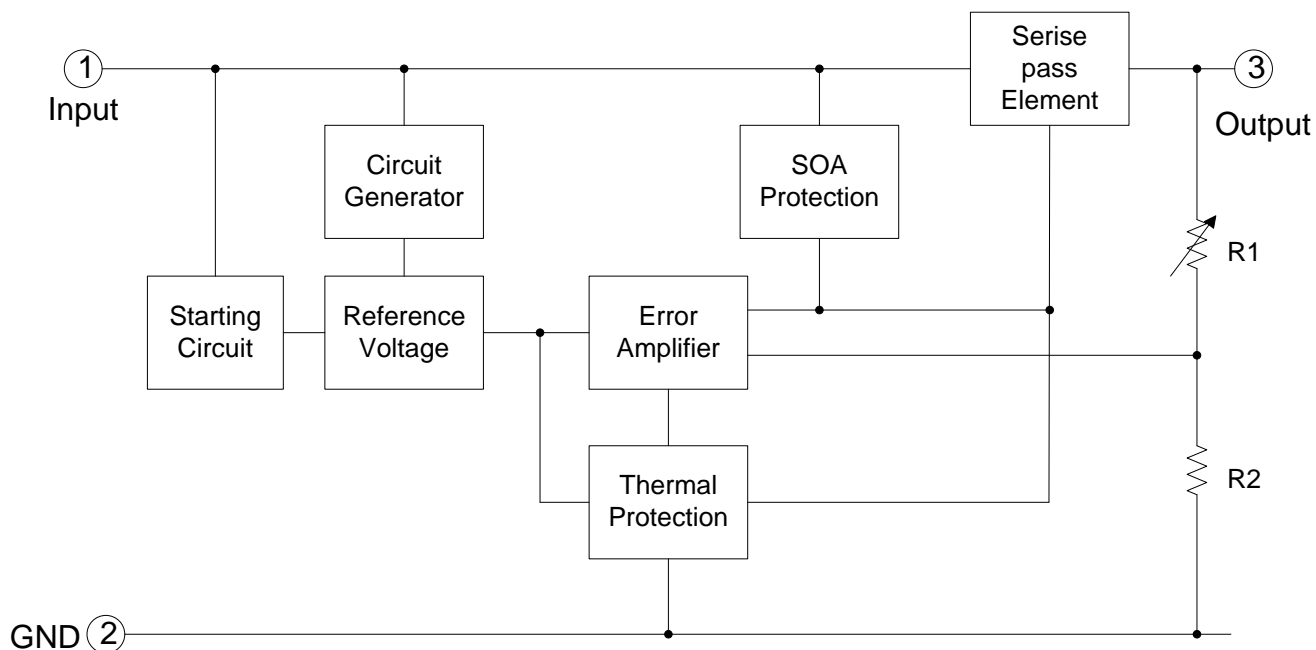

## Electrical Characteristics

( $C_{in} = 0.33\mu F$ ,  $C_o = 0.1\mu F$ ,  $0 \leq T_j \leq 125^\circ C$ , unless otherwise noted)

Parameter	Symbol	Conditions	Min.	Typ.	Max.	Unit
Output Voltage	$V_o$	$I_o = 500mA$ , $V_{IN} = 10V$	4.8	5.0	5.25	V
		$I_o = 1mA \sim 1A$ , $P_o \leq 15W$ $V_{IN} = 8V \sim 20V$	4.65	5.0	5.35	
Line Regulations	LNR	$V_{IN} = 7V \sim 25V$ , $I_o = 500mA$	-	3	50	mV
		$V_{IN} = 8V \sim 25V$ , $I_o = 500mA$	-	1	25	
Load Regulation	LDR	$V_{IN} = 10V$ , $I_o = 5mA \sim 1.2A$	-	-	100	mV
		$V_{IN} = 10V$ , $I_o = 250mA \sim 750mA$	-	-	25	
Dropout Voltage	$V_{DIF}$	$T_j = 25^\circ C$ , $I_o = 100mA$	-	2	-	V
Output noise Voltage	$V_N$	$f = 10Hz$ to $100KHz$	-	10	-	$\mu V/V_o$
Ripple Rejection	PSRR	$T_j = 25^\circ C$ , $f = 120Hz$ , $I_o = 40mA$ $V_{IN} = 8V \sim 20V$	-	68	-	dB
Quiescent Current	$I_Q$	$V_{IN} = 10V$ , $I_{OUT} = 500mA$	-	-	6.0	mA
Quiescent Current Change	$\Delta I_Q$	$V_{IN} = 14.5V \sim 30V$ , $I_o = 500mA$	-	-	0.8	mA
		$V_{IN} = 10V$ , $I_o = 5mA \sim 1A$ ,	-	-	0.5	

LNR: Line Regulation. The change in output voltage for a change in the input voltage. The measurement is made under conditions of low dissipation or by using pulse techniques such that the average chip temperature is not significantly affected.

LDR: Load Regulation. The change in output voltage for a change in load current at constant chip temperature.

## Typical Performance Characteristics

Output Voltage vs. Input voltage

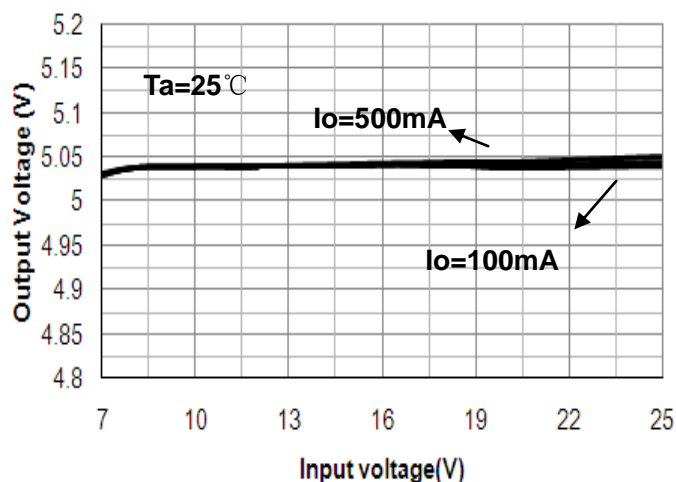

Output Voltage vs. Load

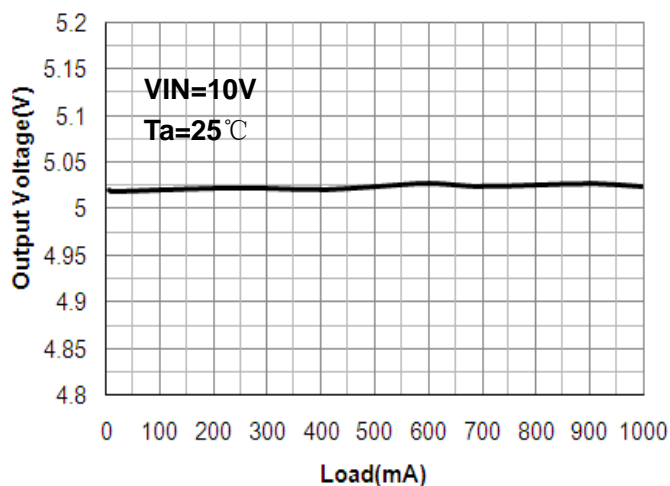

Output Voltage vs. Temperature

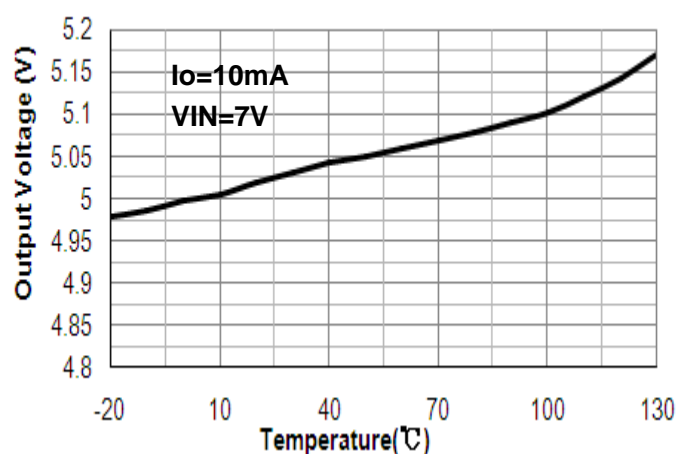

Dropout Voltage vs. Load

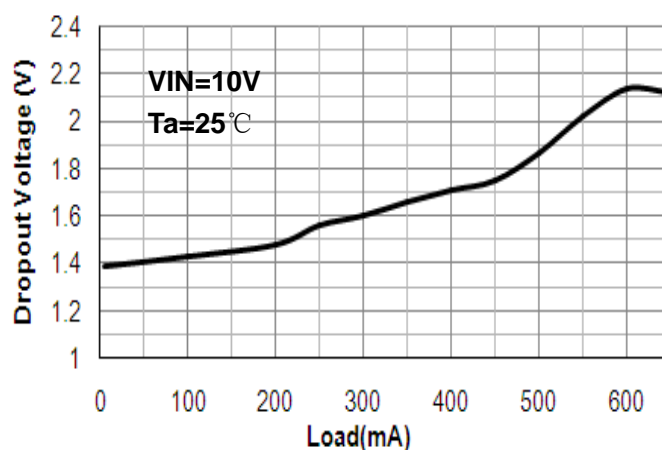

Quiescent Current vs. Input Voltage

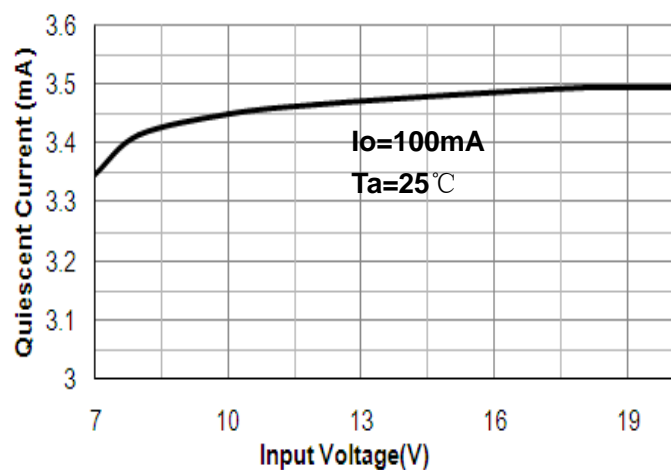

Quiescent Current vs. Load

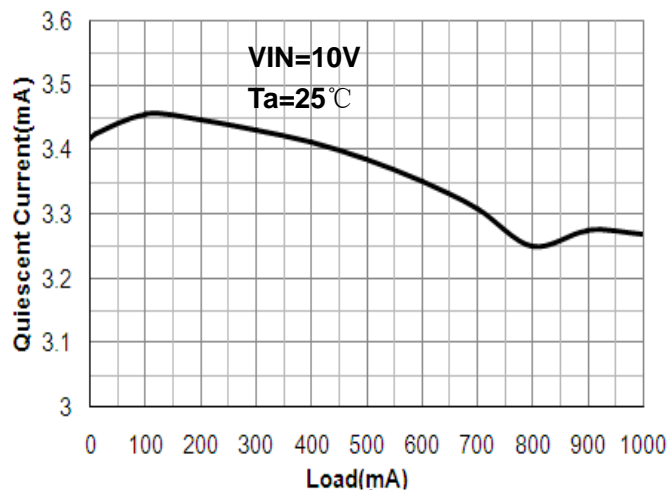

## Operation Description

ME7805 is designed with Thermal Overload Protection that shuts down the circuit when subjected to an excessive power overload condition, Internal Short Circuit Protection that limits the maximum current the circuit will pass, and Output Transistor Safe-Area Compensation that reduces the output short circuit current as the voltage across the pass transistor is increased.

In many low current applications, compensation capacitors are not required. However, it is recommended that the regulator input be bypassed with a capacitor if the regulator is connected to the power supply filter with long wire lengths, or if the output load capacitance is large. An input bypass capacitor should be selected to provide good high frequency characteristics to insure stable operation under all load conditions. A 0.33μF tantalum, mylar, or other capacitor having low internal impedance at high frequencies should be chosen. The bypass capacitor should be mounted with the shortest possible leads directly across the regulator's input terminals. Normally good construction techniques should be used to minimize ground loops and lead resistance drops since the regulator has no external sense lead.

## Typical Application Circuit

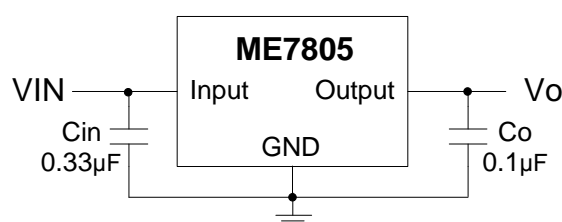

**Fig.1 Fixed Output Regulator**

A common ground is required between the input and the output voltages. The input voltage must remain typically 2.0 V above the output voltage even during the low point on the input ripple voltage.

- Cin is required if regulator is located an appreciable distance from power supply filter.
- Co is not needed for stability; however, it does improve transient response.

The ME7805 regulator can also be used as a current source when connected as Fig.2. In order to minimize dissipation the ME7805 is chosen in this application. Resistor R determines the current as follows:

$$I_o = \frac{5V}{R} + I_Q$$

$$I_Q \cong 3.2\text{mA over line and load changes}$$

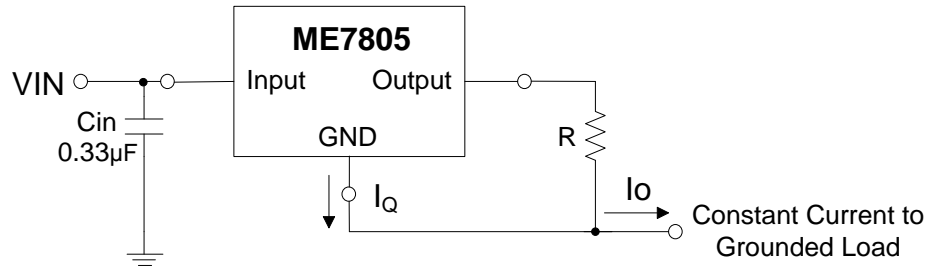

**Fig.2 Constant Current Regulator**

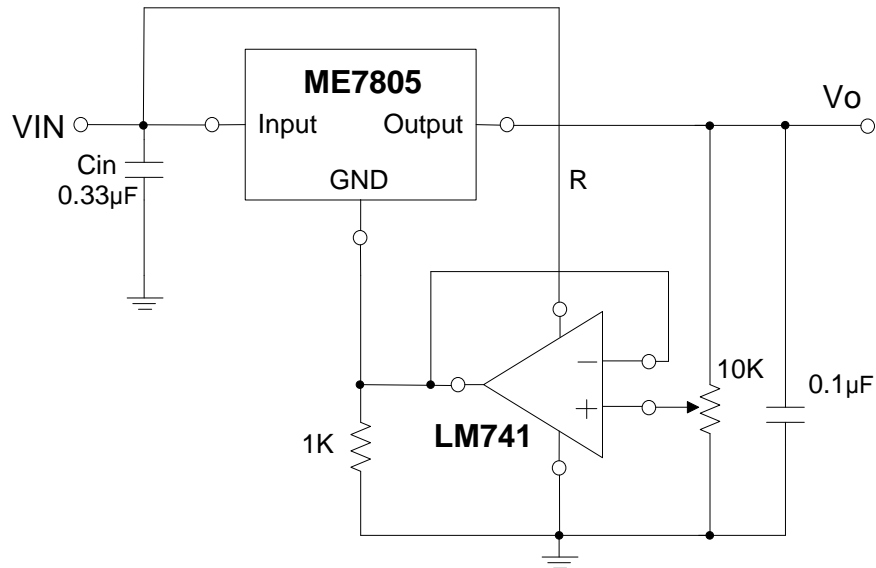
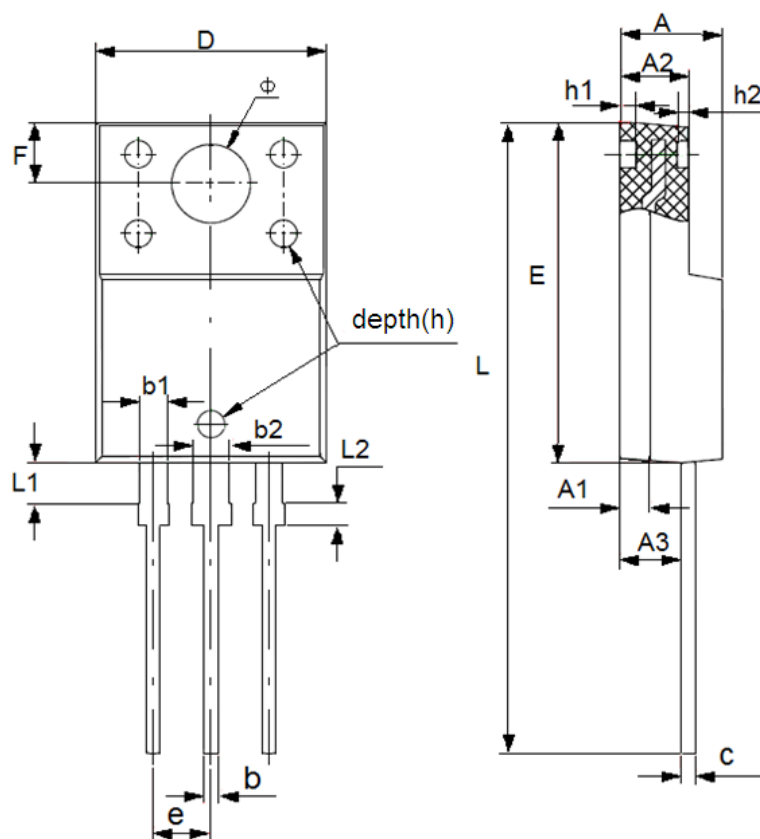

**Fig.3 Adjustable Output Regulator**

The addition of an operational amplifier allows adjustment to higher or intermediate values while retaining regulation characteristics. The minimum voltage obtainable with this arrangement is 2.0 V greater than the regulator voltage.

## Package Information

- Package Type: TO-220



DIM	Millimeters		Inches	
	Min	Max	Min	Max
A	4.3	4.83	0.1693	0.1902
A1	1.3(TYP)		0.0512(TYP)	
A2	2.45	3.2	0.0965	0.126
A3	2.5	2.9	0.0984	0.1142
b	0.5	0.75	0.0197	0.0295
b1	1.1	1.35	0.0433	0.0531
b2	1.5	1.75	0.0591	0.0689
c	0.5(TYP)		0.0197(TYP)	
D	9.96	10.4	0.3921	0.4094
E	14.8	16.1	0.5827	0.6339
e	2.54(TYP)		0.1(TYP)	
F	2.7(TYP)		0.1063(TYP)	
$\Phi$	3.45(TYP)		0.1358(TYP)	
h	0.15(TYP)		0.0059(TYP)	
h1	0.8(TYP)		0.0315(TYP)	
h2	0.5(TYP)		0.0197(TYP)	
L	28	28.8	1.1024	1.1339
L1	1.7	1.9	0.067	0.0748
L2	0.9	1.1	0.0354	0.0433

- The contents of this document will be updated with the product's improvement without prior notice. Please consult our sales staff before using this document to ensure that you are using the latest version.
- The application circuit examples described in this document are only used to indicate the representative use of the product and do not guarantee the design of mass production.
- Please use this product within the limits stated in this document. We will not be responsible for any damage caused by improper use.
- The products described in this document are not allowed to be used in equipment or devices that affect the human body without the written permission of our company, including but not limited to: health equipment, medical equipment, disaster prevention equipment, fuel control equipment, automobile equipment, aviation equipment and vehicle equipment.
- Although our company has always been committed to improving product quality and reliability, semiconductor products have a certain probability of malfunction or wrong work. To prevent personal injury or property damage caused by such accidents, please pay full attention to safety design, for example: Alternate design, fire protection design, and prevention of wrong action design.
- When exporting this product or this document overseas, you should abide by applicable import and export control laws.
- Copying or reprinting part or all of this document in any form without the permission of our company is strictly prohibited.